

2008
M
C

MG ADVANTAGES

Twistin' Wrists & Turnin' Heads

MCC

ADVANTAGES

08



01: Stacey Campbell // 02: Todd Brummer // 03: Adam Roorda // 04: Scott "Scottie Mac" Mc Atee // 05: Kent Reed // 06: Jay Hoodjer // 07: Sheila Moen // 08: Steve Campbell // 09: Kathy Stark // 10: Chris Willadsen // 11: Tom Higgins // 12: Kenny Lilly // 13: Scooter Flaig // 14: Rich "Geezer" Bruns // 15: Dan Depping // 16: Bob Abrams



Twistin' Wrists & Turnin' Heads

Welcome To 2008!

Wow, another great year is here for the V-Twin industry. At MC Advantages, we're looking forward to our 16th year with a new look and a new motto. We've adopted a new logo that represents our company's drive to soar to the next challenge and promptly deliver the best performance parts and cool accessories to the entire industry. That's the primary reason our tagline is now:

Twistin' Wrists & Turnin' Heads

In order to keep those wrists twistin', we've added the product lines of Crane Cams®, Daytona Twin Tec, Compu-Fire® and Pure Power! Oil Products. We've also added a **completely new Bagger section** for all the touring items that have sprung to market in the last year. This section is packed with new products from Hi-Lo Rider, Wicked Image, Paul Yaffe Originals, Dragonfly Cycle Concepts, Hell's Foundry, Sumax and many others.

Check them all out online at either dealers.mcadvantages.com or on the Dealer Driven Web Shop at MCAdvantages.com. Have an outstanding 2008!

Ride Safe,

Kent Reed
MC Advantages General Manager, kent@mcadvantages.com



MC Advantages Decal Kit

We've got a set of five decals to dress up any operation — from the stunning new MC Advantages chrome decals; the blinged out Prowler® and Spyke® monikers; the cool, bullet hole-cut Bulletprüf® icon and the Stampede™ nameplate.

PART	DESCRIPTION	MSRP
MCDEC	MC Decal Kit	\$5.00

MC Advantages Dealer Signage Kit



With a new logo comes a new set of high quality PVC signs that can be used separately or laid over one another to create a huge point-of-purchase awareness

PART	DESCRIPTION	MSRP
MCBANW	"Wings" Sign, 34" x 15.5"	\$49.99
MCBANAD	"Authorized Dealer" Sign, 60" x 9"	\$49.99
MCBANWD	Combined Sign Kit, 60" x 15.5"	\$89.99

ALL NEW FOR 2008

S&S® P-Series Engines



Crane Cams Products



Pure Power! Oil



Daytona Twin Tec Products



Battery Tender



Compu-Fire Products®



Duro Tires



Motion Pro Cables & Tools



Stampede™ Fuel Tank Liner



Hi-Lo Rider Shocks



Dragonfly Cycle Concepts Products



Hell's Foundry Products



Paul Yaffe Originals Products



Sumax Products



Wham Bam Cleaners



Kal-Gard Products



Equal Tire Products



Golan Petcocks



Force Dominator Intake



Neon Hot Wires



ENGINE	Engines, Engine Packages, Hot Set Up, Stroker Kits, Flywheels, Cams, Tappets, Pushrods, Heads, Case Vents, Oil Pumps, Oil Filters
FUEL SYSTEMS	Oil, Fuel Supplements, Air Filters, Hoses, Fuel Filters, Petcocks, Gaskets, Tuning Modules, Carburetors, Velocity Stacks, Air Cleaners, Quick Set Up Kits
EXHAUST	Mufflers, Slip-On Pipes, Performance Exhaust, Exhaust Gaskets, Exhaust Tips, Pipe Polish
ELECTRICAL	Ignitions, Coil Covers/Motor Mounts, Jackshafts, Starters, Batteries, Battery Testers, Wiring, Battery Cables, Plug Wires
DRIVETRAIN	Clutch, Transmissions, Shift Linkages, Belts, Chains, Driveline Packages, Belt Drives, Chain Drives, Primary Covers, Belt Drive Covers, Belt Guards
WHEELS	Billet Wheels, Spoked Wheels, Rotors, Pulleys, Sprockets, Sprotors, Brakes, Tires
SUSPENSION	Shocks For Softail®, External Shocks, Front Ends, Lowering Kits, Fork Braces
SHEETMETAL	Axles, Swingarms, Wide Tire Kits For XL & Softail®, Fenders, Oil Tanks, Gas Tanks, Gas Caps, Seats, Sissy Bars
FRAMES	Rigids, Hidden Suspension, Rigid Conversion Kits For XL, Single-Sided Swingarms
CONTROLS	Handlebars, Internal Throttle/Clutch, Risers, Switches, Cables, Levers, Grips, Foot Pegs, Kickstands, Shifters, Forward Controls, Mirrors
LIGHTING	Headlights, Headlamps, Marker Lights, Taillights, License Plate Frames, Light Modules, Gauges, Gauge Cups & Mounts, Security Systems
BAGGERS	Engines, Exhaust, Shocks, Shifters, Wide Tire Kits, Axles, Fairings, Windshields, Stereo, Striping Kits, Gauges, Handlebars, Dashes, Mirrors, Fenders, Bags, Lighting
TOOLS	Blowers, Cleaners, Lubricants, Chocks, Bottom End, Top End, Wheels, Tire Balancing, Emergency Tool Kits
APPAREL	Coats, Rain Suits, T-Shirts, Gloves, Chaps, Vests, Pillion Pads, Helmets Software



ENGINE
FUEL SYSTEMS
EXHAUST
ELECTRICAL
DRIVE/RAIN
WHEELS
SUSPENSION
SHEETMETAL
FRAMES
CONTROLS
LIGHTING
BAGGERS
TOOLS
APPAREL

New S&S® Engine Warranties w/ S&S Ignitions

120"+ Engine w/ IST Ignition or Delphi®-Style VFI..... 2 years
 120"+ Engine w/ Super Stock® Ignition or Magneti Marelli®-Style VFI..... 1 year
 Up To 119" Engine w/ IST Ignition or Delphi®-Style VFI..... 3 years
 Up To 119" Engine w/ Super Stock® Ignition or Magneti Marelli®-Style VFI.... 2 years

A. S&S® 92" Classic Round Cylinder Engine

Years of devoted S&S® parts distribution allows us to bring you this exclusive classic engine. With a 3 7/8" bore x 3 7/8" stroke, this smooth powerhouse uses a 520 Cam. Each engine comes with an S&S Super E Carburetor, Super Stock® Ignition (single-fire upgrade available) & two year limited warranty. Base your next build on this dependable powerhouse you'll only get from us.

PART	DESCRIPTION	MSRP
SS319327	92" Classic Round Cylinder Engine, Black	\$6,599.00
SS318033	92" Classic Round Cylinder Engine, S&S® Polished	\$7,299.00
SS318031	92" Classic Round Cylinder Engine, Natural	\$6,199.00

B. S&S® V124 Complete Carbureted Engines '84-'99 BT Chassis

Completely assembled with Super G carburetor, chrome die-cast rocker boxes, electronic compression releases, billet tappet guides, gearcover, S&S® Oil Filter, spark plugs and Mobil 1® motor oil.

PART	DESCRIPTION	MSRP
SS319860	Natural Finish w/ Super Stock® Ignition	\$7,955.00
SS319528	Natural Finish w/ IST Ignition	\$8,445.00
SS319885	Black Finish w/ Super Stock® Ignition	\$8,280.00
SS319552	Black Finish w/ IST Ignition	\$8,770.00
SS319886	S&S® Polished Finish w/ Super Stock® Ignition	\$9,055.00
SS319553	S&S® Polished Finish w/ IST Ignition	\$9,545.00
SS319526X	Between the Fins Show Polished w/o Ignition	\$9,399.00

C. S&S® V124 Complete FI Engines For '95-'98 FI Chassis

All engines come completely assembled with S&S® Magneti Marelli®-Style VFI module, chrome die-cast rocker boxes, electronic compression releases, billet tappet guides, gearcover, S&S Oil Filter, spark plugs and Mobil 1® motor oil. Air Cleaner or tuned induction kit must be purchased separately.

PART	DESCRIPTION	MSRP
SS1060565	Natural Finish	\$9,115.00
SS1060566	Black Finish	\$9,440.00
SS1060567	S&S® Polished	\$10,215.00

Fuel Systems

SS170413	VFI Dual Bore Teardrop A/C Induction Kit, Chrome	\$199.95
SS175051	VFI Dual Bore Tuned Induction Kit, Natural	\$439.95
SS175052	VFI Dual Bore Tuned Induction Kit, Black	\$449.95
SS175100	VFI Dual Bore Tuned Induction Kit, Chrome	\$469.95

D. S&S® V113 Complete Carbureted Engines '84-'99 BT Chassis

All engines come completely assembled with Super G carburetor, chrome die-cast rocker boxes, electronic compression releases, billet tappet guides, gearcover, S&S® Oil Filter, spark plugs and Mobil 1® motor oil.

PART	DESCRIPTION	MSRP
SS319491	Natural w/ Super Stock® Ignition	\$6,465.00
SS319488	Natural w/ IST Ignition	\$6,945.00
SS319492	Black Finish w/ Super Stock® Ignition	\$6,790.00
SS319489	Black Finish w/ IST Ignition	\$7,270.00
SS319493	S&S® Polished Finish w/ Super Stock® Ignition	\$7,565.00
SS319490	S&S® Polished Finish w/ IST Ignition	\$8,045.00

E. S&S® V96 Complete Carbureted Engines, '84-'99 BT Chassis

All engines come completely assembled with Super E carburetor, chrome die-cast rocker boxes, billet tappet guides, gearcover, S&S® Oil Filter, spark plugs and Mobil 1® motor oil.

PART	DESCRIPTION	MSRP
SS319752	Natural, Billet Options w/ IST Ignition	\$6,250.00
SS319857	Natural, Billet Options w/ Super Stock® Ignition	\$5,590.00
SS319856	Natural, Cast Options w/ Super Stock® Ignition	\$5,285.00
SS319753	Black, Billet Options w/ IST Ignition	\$6,575.00
SS319858	Black, Billet Options w/ Super Stock® Ignition	\$5,915.00
SS319759	Polished, Billet Options w/ IST Ignition	\$7,350.00
SS319859	Polished, Billet Options w/ Super Stock® Ignition	\$6,690.00

A.

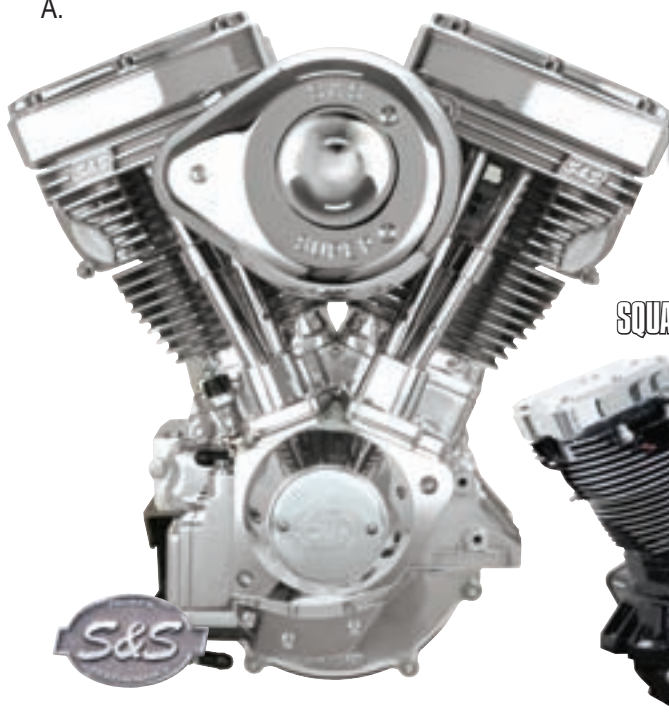

CLASSIC
ROUND
92"

SQUARE BORE & STROKE!



B.

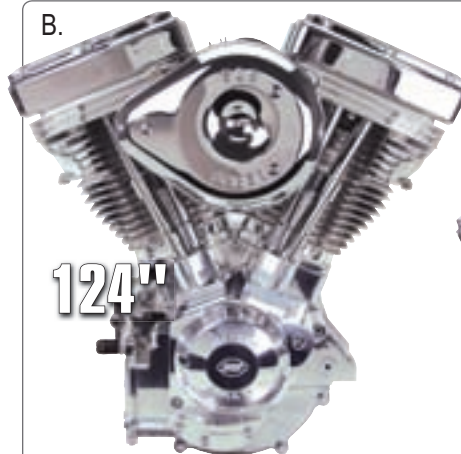

OUR MOST POPULAR
LARGE DISPLACEMENT
ENGINE!

C.

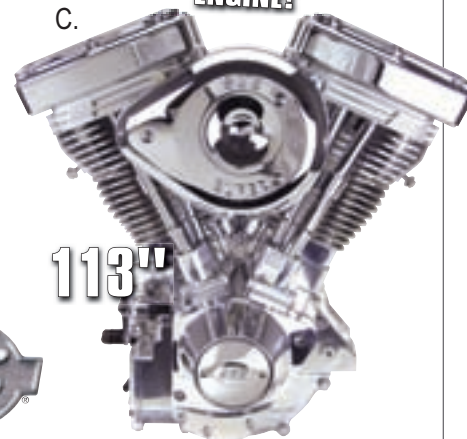

D.

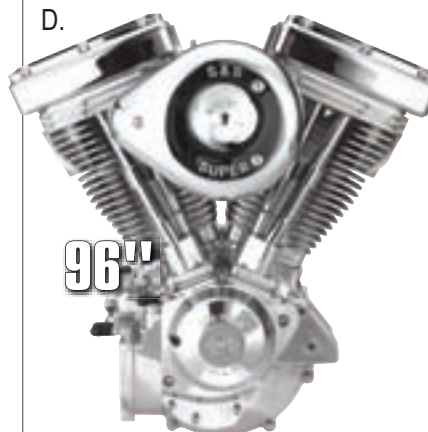

All S&S Engines Are
Now Tested For The
Following Engine
Parameters:

- Oil pressure
- Cylinder pressure
- Cam chest pressure
- Crankcase pressure/vacuum
- Vibration
- Compression release function (if equipped)
- Sensor function (crank position and head temp if equipped)

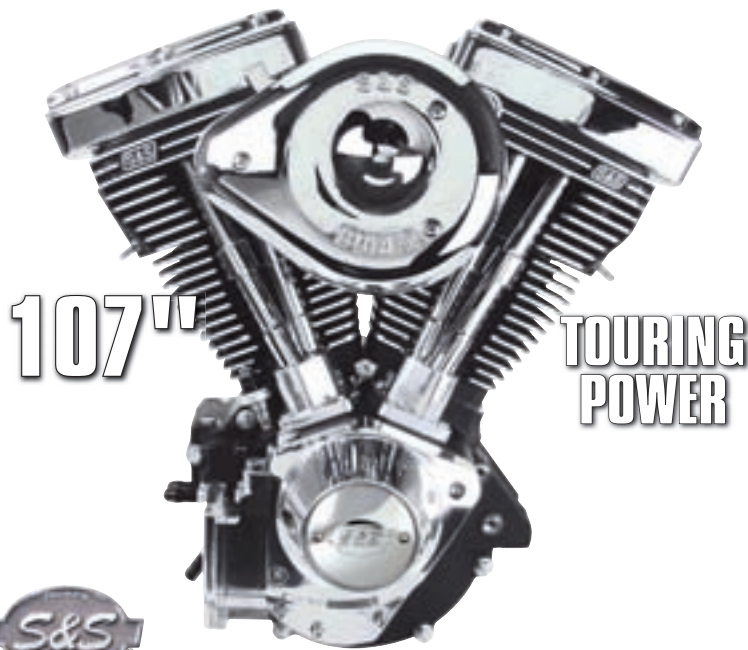

A.

A. S&S® V107T Complete Touring Special Engines

Carbureted fits '84-'99 chassis. EFI fits '95-'98 FI chassis. All engines come completely assembled with Super E carburetor or Magneti Marelli®-Style VFI Module, air cleaner, chrome die-cast rocker boxes, electronic compression releases, billet tappet guides, gearcover, S&S® oil filter, spark plugs and Mobil 1® motor oil.

PART	DESCRIPTION	MSRP
SS319480	Carbureted, Natural w/ Super Stock® Ignition	\$5,995.00
SS319479	Carbureted, Natural w/ IST Ignition	\$6,410.00
SS319482	Carbureted, Black w/ Super Stock® Ignition	\$6,320.00
SS319481	Carbureted, Black w/ IST Ignition	\$6,735.00
SS319484	Carbureted, S&S® Polished w/ Super Stock® Ignition	\$7,095.00
SS319483	Carbureted, S&S® Polished w/ IST Ignition	\$7,510.00
SS1060786	Single-Bore EFI, Natural w/ VFI Module	\$7,140.00
SS1060787	Single-Bore EFI, Black Finish w/ VFI Module	\$7,465.00
SS1060788	Single-Bore EFI, S&S® Polished w/ VFI Module	\$8,240.00

VFI Fuel Systems

SS165135	Single Bore EFI Manifold	\$119.95
SS170498	VFI Single Bore Teardrop Induction Kit, Chrome	\$199.95
SS170497	VFI Single Bore Desperado Induction Kit, Chrome	\$199.95
SS171001	VFI Single Bore Tuned Induction Runner Kit, Natural	\$239.95
SS171003	VFI Single Bore Tuned Induction Runner Kit, Black	\$259.95
SS171005	VFI Single Bore Tuned Induction Runner Kit, Chrome	\$324.95
SS171047	Single Bore Tuned Induction Bracket Kits	\$374.95

New S&S® Engine Warranties w/ S&S Ignitions

- 120"+ Engine w/ IST Ignition or Delphi®-Style VFI..... 2 years
- 120"+ Engine w/ Super Stock® Ignition or Magneti Marelli®-Style VFI..... 1 year
- Up To 119" Engine w/ IST Ignition or Delphi®-Style VFI..... 3 years
- Up To 119" Engine w/ Super Stock® Ignition or Magneti Marelli®-Style VFI..... 2 years

B. S&S® T124 Engines For '99-'05/'06 Chassis (Except Dyna®)

- Completely assembled with Super G carburetor or S&S® VFI module, teardrop air cleaner, chrome die-cast rocker boxes, electronic compression releases, billet tappet guides, gearcover, S&S® Oil Filter and Mobil 1® motor oil.
- Installation of an S&S® T124 engine in '99-'05 Dyna® models requires oil line installation kit SS310424
- If installing in '99-'06 FLT/FLH models, the stock transmission top cover may be used, but oil line installation kit SS310425 is required
- Engines with internal counter balancers are not available from S&S to replace H-D® Twin Cam 88B® engines
- Engines are not available for '06 Dyna® models or any '07 models.

PART	DESCRIPTION	MSRP
SS319894	Carbureted, Natural w/ IST Ignition, '99-'06	\$8,845.00
SS319895	Carbureted, Black w/ IST Ignition, '99-'06	\$9,170.00
SS319896	Carbureted, S&S® Polish w/ IST Ignition, '99-'06	\$10,645.00
SS1060398	MM-Style VFI, Single Bore, Natural, '99-'01	\$9,415.00
SS1060399	MM-Style VFI, Single Bore, Black, '99-'01	\$9,699.00
SS1060400	MM-Style VFI, Single Bore, S&S® Polished, '99-'01	\$10,699.00
SS1060401	Delphi®-Style VFI, Single Bore, Natural, '02-'05	\$9,265.00
SS1060402	Delphi®-Style VFI, Single Bore, Black, '02-'05	\$9,590.00
SS1060403	Delphi®-Style VFI, Single Bore, S&S® Polish, '02-'05	\$10,590.00

Induction Kits (Optional)

SS171007	EFI Single Bore Tuned Induction Runner, Natural	\$164.95
SS171009	EFI Single Bore Tuned Induction Runner, Black	\$184.95
SS171012	EFI Single Bore Tuned Induction Runner, Chrome	\$249.95
SS171046	Single Bore Bracket	\$374.95

C. S&S® T124V Engines For '84-'99 Chassis

All carbureted engines come completely assembled with Super G carburetor or VFI Module, teardrop air cleaner, chrome die-cast rocker boxes, electronic compression releases, billet tappet guides, gearcover, S&S Oil Filter, spark plugs and Mobil 1® motor oil. Air cleaner or tuned induction kit must be purchased separately for FI engines.

T124V engines replace stock H-D® Evolution® engines in '84-'99 BT.

PART	DESCRIPTION	MSRP
SS319709	Carbureted, Natural w/ IST Ignition	\$8,845.00
SS319713	Carbureted, Black w/ IST Ignition	\$9,170.00
SS319714	Carbureted, S&S Polish w/ IST Ignition	\$10,645.00
SS1060516	MM-Style VFI, Natural® w/ VFI Module	\$9,675.00
SS1060517	MM-Style VFI, Black® w/ VFI Module	\$10,000.00

Induction Kits (Optional)

SS175051	VFI Tuned Induction Kit, Burnished	\$439.95
SS175052	VFI Tuned Induction Kit, Black	\$449.95
SS175100	VFI Tuned Induction Kit, Chrome	\$469.95

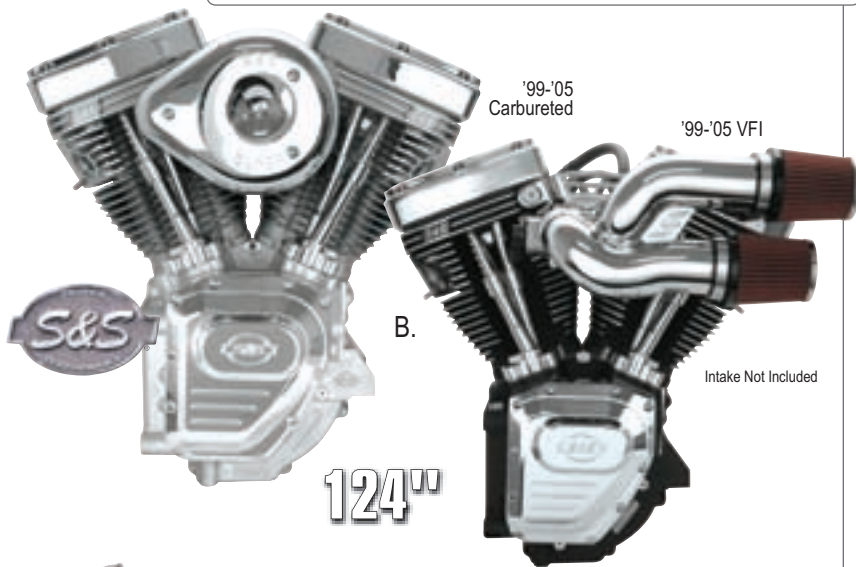

B.

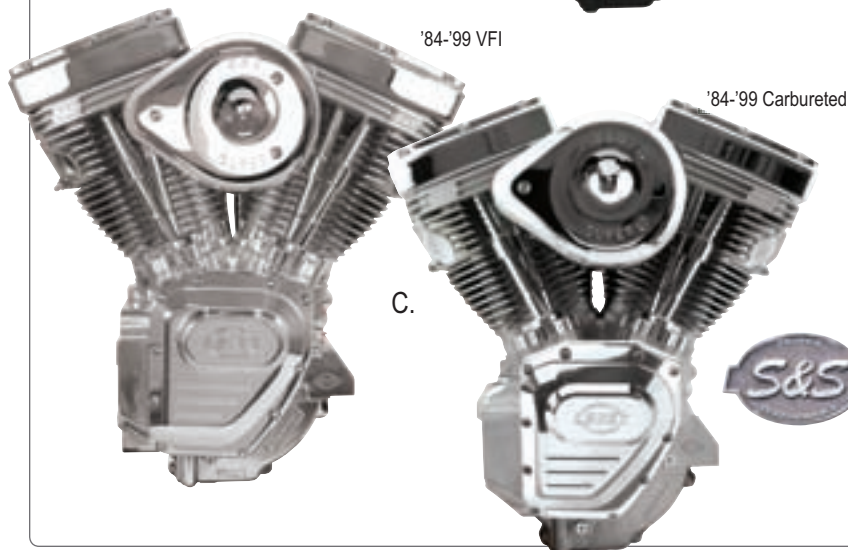

C.

New S&S® Engine Warranties w/ S&S Ignitions

120"+ Engine w/ IST Ignition or Delphi®-Style VFI..... 2 years
 120"+ Engine w/ Super Stock® Ignition or Magneti Marelli®-Style VFI..... 1 year
 Up To 119" Engine w/ IST Ignition or Delphi®-Style VFI..... 3 years
 Up To 119" Engine w/ Super Stock® Ignition or Magneti Marelli®-Style VFI.... 2 years
 MC Show-Polished Engines 2 year upgrade available

A. S&S® P-Series Complete Carbureted Engines, '48-'99 Chassis

- Retro styling with modern technology
- New head design based on S&S® heads for shovels
- Uses S&S® roller rockers for shovel engines 1,500 torque
- Uses readily available S&S® cylinders for shovels
- S&S hydraulic valve train.
- S&S Super Stock® ignition and billet timer
- 93", 93" high compression and 103" displacements
- '54-'64, '65-'69, and custom alternator/generator styles

PART	DESCRIPTION	MSRP
SS1060819	P93, '54-'65 Generator '48-'64*	\$7,995.00
SS1060820	P93, '65-'69 Generator	\$7,995.00
SS1060821	P93, Alternator/Generator Custom	\$8,195.00
SS1060822	P93H, '54-'65 Generator	\$8,195.00
SS1060823	P93H, '65-'69 Generator	\$8,195.00
SS1060824	P93H, Alt/Gen Custom	\$8,195.00
SS1060825	P103, '54-'65 Generator	\$8,295.00
SS1060826	P103, '65-'69 Generator	\$8,295.00
SS1060827	P103, Alt/Gen Custom	\$8,295.00

A.

PAN POWER!

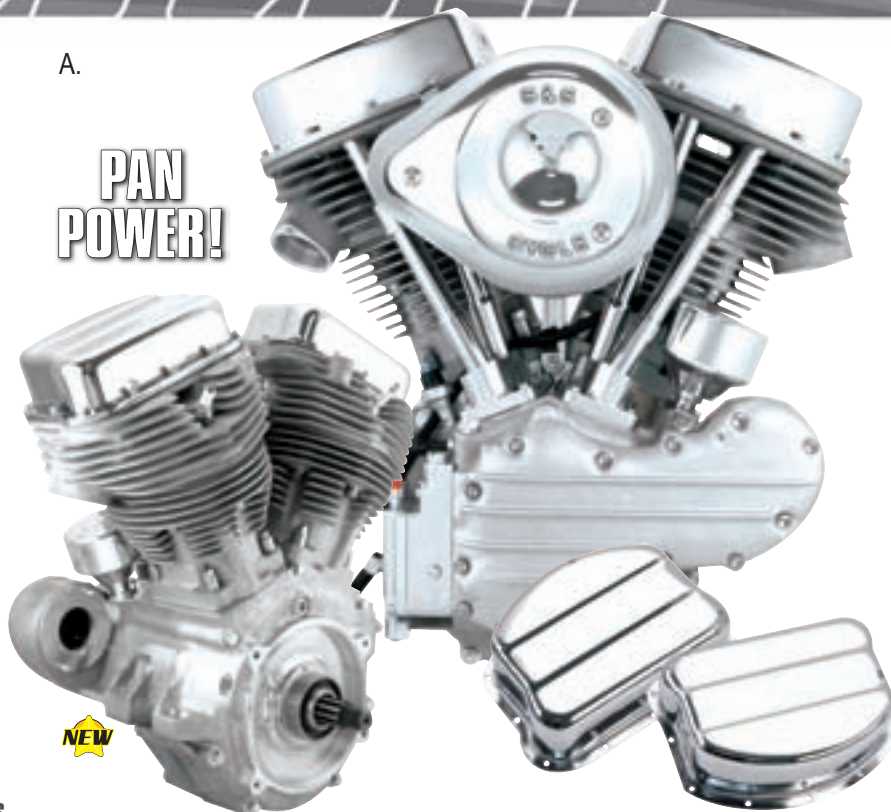

B. S&S® SH-Series Complete Carbureted Engines, '70-'84 Chassis

These engines are completely assembled with Super G carburetor, S&S® Super Stock Ignition, billet rocker boxes, roller rocker arms, billet tappets, tappet guides, S&S Oil Filter and Mobil 1® motor oil. NOTE: SH103 engine is .300" taller than a stock shovelhead.

PART	DESCRIPTION	MSRP
SS319919	SH103, Alternator Dual Plug, Cast Gearcover, '70-'84 Chassis, .300" over stock	\$7,480.00
SS319904	SH93, Alternator Single Plug, Cast Gearcover, '70-'84 Chassis	\$7,180.00
SS319905	SH93, Alternator Single Plug, Billet Gearcover, '70-'84 Chassis	\$7,395.00
SS319906	SH93, Generator Single Plug, Cast Gearcover, '66-'69 Chassis	\$8,095.00
SS319977	SH93, Generator Single Plug, Billet Gearcover, '66-'69 Chassis	\$8,330.00
SS319917	SH93, Alternator/Generator Single Plug, Cast Gearcover, Custom Chassis	\$8,100.00
SS319979	SH93, Alternator/Generator Single Plug, Billet Gearcover, Custom Chassis	\$8,340.00
SS319907	SH93H, Alternator Dual Plug, Cast Gearcover, '70-'84 Chassis	\$7,255.00
SS319908	SH93H, Alternator Dual Plug, Billet Gearcover, '70-'84 Chassis	\$7,470.00
SS319909	SH93H, Generator Dual Plug, Cast Gearcover, '66-'69 Chassis	\$8,170.00
SS319978	SH93H, Generator Dual Plug, Billet Gearcover, '66-'69 Chassis	\$8,400.00
SS319918	SH93H, Alternator/Generator Dual Plug, Cast Gearcover, Custom Chassis	\$8,175.00
SS319980	SH93H, Alternator/Generator Dual Plug, Billet Gearcover, Custom Chassis	\$8,415.00
SS319901	SH80, Alternator Single Plug, Cast Gearcover, '70-'84 Chassis	\$7,165.00
SS319902	SH80, Alternator Single Plug, Billet Gearcover, '70-'84 Chassis	\$7,380.00
SS319903	SH80, Generator Single Plug, Cast Gearcover, '66-'69 Chassis	\$8,080.00
SS319976	SH80, Generator Single Plug, Billet Gearcover, '66-'69 Chassis	\$8,315.00

C. S&S® Engines For Buell® & Sportster®

Requires purchase of S&S Billet Motor Mount. Call for part numbers.

PART	DESCRIPTION	MSRP
SS319891	100" Engine For Sportster®, Natural	\$8,895.00
SS319893	100" Engine For Buell®, Natural	\$9,095.00
SS319890	91" Engine For Sportster®, Natural	\$8,895.00
SS319892	91" Engine For Buell®, Natural	\$9,095.00

C.



B.

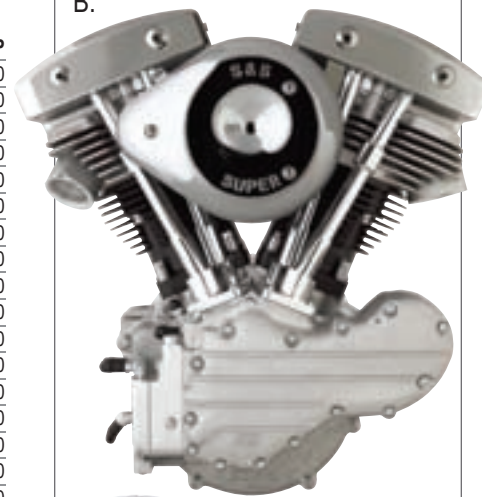

SHOVEL POWER!

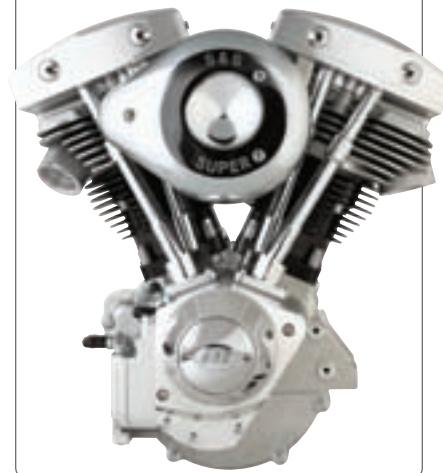

**OIL, FILTER & SPARK
PLUGS NOW INCLUDED!**

*Filter in '84-Later Chassis Engines Only



A.

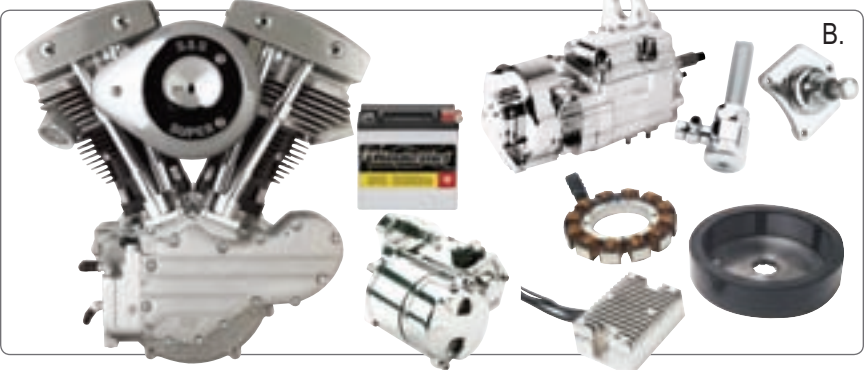

B.

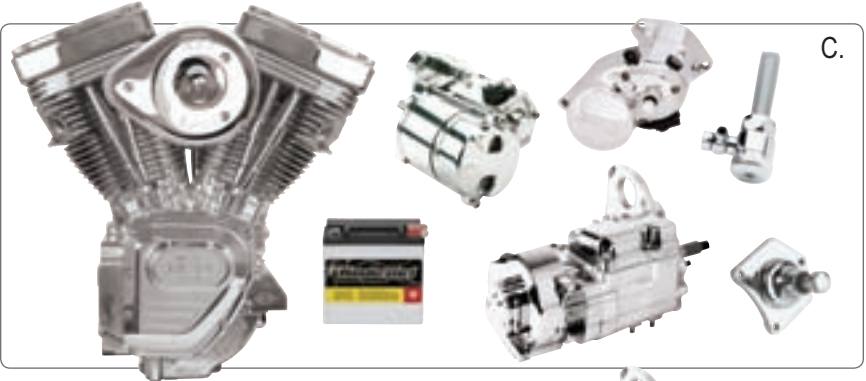

C.



D.



E.



New S&S® Engine Warranties w/ S&S Ignitions

120"+ Engine w/ IST Ignition or Delphi®-Style VFI.....	2 years
120"+ Engine w/ Super Stock® Ignition or Magneti Marelli®-Style VFI.....	1 year
Up To 119" Engine w/ IST Ignition or Delphi®-Style VFI.....	3 years
Up To 119" Engine w/ Super Stock® Ignition or Magneti Marelli®-Style VFI.....	2 years
MC Show-Polished Engines.....	2 year upgrade available

SAVE BIG ON PACKAGE DEALS!

A. 92" S&S® Classic Round Engine Packages

- Available exclusively from MC Advantages.
- Classic round S&S® polish, black or natural cylinders with chrome rocker covers
- Comes with ignition and two year warranty
- Comes with S&S® Super E Carburetor
- Uses a 520 Cam
- 3 7/8" Bore x 3 7/8" stroke
- 9:1 compression ratio

BLACK, NATURAL OR POLISHED!

Get that classic look with a complete engine package! MC Advantages Engine Powertrain Packages are available with a 92" S&S® Classic Round-Cylinder Engine, ignition, Prowler® 6-Speed Transmission, Spyke® Charging System with Chrome Voltage Regulator, Ignition, Spyke Universal Petcock, Thunderstart™ 340 CCA Battery (2 Year Warranty), Spyke SuperTorque or Stealth Chrome Starter and Spyke Starter Button. Available upgrades include Prowler® Right-Side Drive Transmission. Bulletproof™ Chain or Belt primaries available for even more savings!

See Back Pages Of Price List For Special Package Pricing!

B. S&S® SH-Series Engine Packages

For vintage power at an effective price, MC Advantages offers a great package to get that S&S® 103", 93" or 80" Shovelhead moving down the road. MC Advantages Shovelhead Engine Powertrain Packages are available with engine, Prowler® 6-Speed Transmission, Spyke Universal Petcock, Thunderstart™ 340 CCA Battery (2 Year Warranty), Spyke SuperTorque or Stealth Chrome Starter and Spyke Starter Button. Available upgrades include Prowler® Right-Side Drive Transmission. Bulletproof™ Chain or Belt primaries available for even more savings!

See Back Pages Of Price List For Special Package Pricing!

C. S&S® T-Series Engine Packages

The future is now! Take the most advanced technology that S&S® offers and pair it up to one of our packages to get the most bang for your buck. MC Advantages T-Series Powertrain Packages are available with engine, ignition, Prowler® 6-Speed Transmission, Spyke Universal Petcock, Thunderstart™ 340 CCA Battery (2 Year Warranty), Spyke SuperTorque or Stealth Chrome Starter and Spyke Starter Button. Available upgrades include Prowler® Right-Side Drive Transmission. Bulletproof™ Chain or belt primaries available for even more savings!

See Back Pages Of Price List For Special Package Pricing!

D. S&S® V-Series Engine Packages

The gold standard. Our longest running line of engines are available with engine, ignition, Prowler® 6-Speed Transmission, Spyke® Charging System with Chrome Voltage Regulator, Spyke Universal Petcock, Thunderstart™ 340 CCA Battery (2 Year Warranty), Spyke SuperTorque or Stealth Chrome Starter and Spyke Starter Button. Available upgrades include Prowler® Right-Side Drive Transmission. Bulletproof™ Chain or Belt primaries available for even more savings!

See Back Pages Of Price List For Special Package Pricing!

E. S&S® P-Series Engine Packages

For classic power at an effective price, MC Advantages offers a great package to get that S&S® 103" or 93" Panhead moving down the road. MC Advantages Shovelhead Engine Powertrain Packages are available with engine, Prowler® 6-Speed Transmission, Spyke Universal Petcock, Thunderstart™ 340 CCA Battery (2 Year Warranty), Spyke SuperTorque or Stealth Chrome Starter and Spyke Starter Button. Available upgrades include Prowler® Right-Side Drive Transmission. Bulletproof™ Chain or Belt primaries available for even more savings!

See Back Pages Of Price List For Special Package Pricing!



MC
ADVANTAGES

88

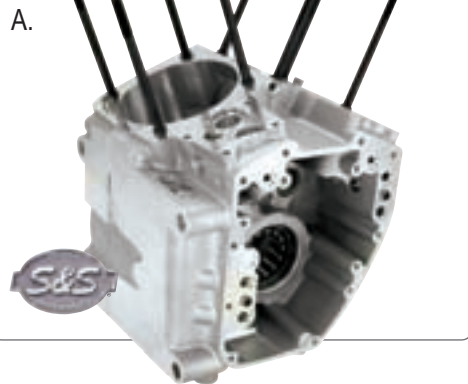

A. S&S® Crankcases For Twin Cam 88® Engines

These cases are available for Twin Cam 88® engines in '99-'06 models, except '06 Dyna®. Dyna® requires oil line install kit. Cases with internal counter balances are not available from S&S®.

PART	DESCRIPTION	MSRP
Stock Bore		
SS310171	Natural, '99-Later Chassis	\$1,449.95
SS310172	Black, '99-Later Chassis	\$1,569.95
SS310173	S&S Polished, '99-Later Chassis	\$2,649.95
SS310133	Natural, '84-'99 Chassis	\$1,449.95
SS310134	Black, '84-'99 Chassis	\$1,569.95
4" Bore		
SS310174	Natural, '99-Later Chassis	\$1,449.95
SS310175	Black, '99-Later Chassis	\$1,569.95
SS310176	S&S Polished, '99-Later Chassis	\$2,649.95
SS310130	Natural, '84-'99 Chassis	\$1,449.95
SS310131	Black, '84-'99 Chassis	\$1,569.95
4.125" Bore		
SS310180	Natural, Stock Stud, '99-Later	\$1,574.95
SS310177	Natural, S&S® Stud, '99-Later	\$1,574.95
SS310181	Black, Stock Stud, '99-Later	\$1,694.95
SS310178	Black, S&S® Stud, '99-Later	\$1,694.95
SS310182	S&S Pol., Stock Stud, '99-Later	\$2,774.95
SS310179	S&S Pol., S&S® Stud, '99-Later	\$2,774.95
SS310127	Natural, Stock Stud, '84-'99	\$1,574.95
SS310128	Black, Stock Stud, '84-'99	\$1,694.95

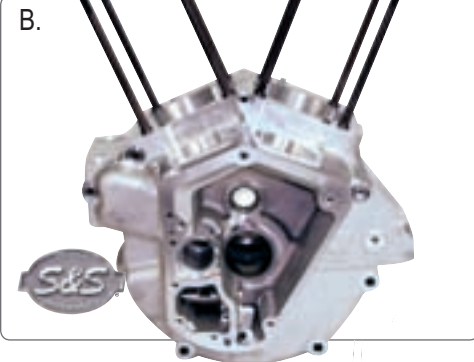

B. S&S® Crankcases For '70-'99 Big Twins

PART	DESCRIPTION	MSRP
Stock Bore		
SS310003	Natural, '70-'84 BT (Alternator)	\$1,049.95
SS310000	Natural, '84-'91 BT	\$1,039.95
SS310052	Black, '84-'91 BT	\$1,159.95
SS310005	Natural, '92-'99 BT	\$1,039.95
SS310055	Black, '92-'99 BT	\$1,159.95
3.625" Bore		
SS310004	Natural, '70-'84 BT (Alternator)	\$1,049.95
SS310001	Natural, '84-'91 BT	\$1,039.95
SS310053	Black, '84-'91 BT	\$1,159.95
SS310077	Natural, '92-'99 BT	\$1,039.95
SS310078	Black, '92-'99 BT	\$1,159.95
SS310079	Polished, '92-'99 BT	\$1,524.95
4" Bore		
SS310027	Natural, '70-'84 BT (Alternator)	\$1,349.00
SS310024	Natural, '84-'91 BT	\$1,249.95
SS310054	Black, '84-'91 BT	\$1,369.95
SS310047	Natural, '92-'99 BT	\$1,249.95
SS310051	Black, '92-'99 BT	\$1,369.95
SS310067	Polished, '92-'99 BT	\$1,689.95
4.125" Bore		
SS310033	Natural, '84-'99 BT	\$1,289.95
SS310037	Black, '84-'99 BT	\$1,409.95
SS310039	Polished, '84-'99 BT	\$1,729.95



C. S&S® Crankcases For '36-'69 & Generators

PART	DESCRIPTION	MSRP
Stock Bore		
SS310006	'36-'47 Knucklehead	\$1,439.95
SS310008	'48-'68 Panhead	\$1,439.95
SS310010	'65-'69 Panhead Or Shovelhead	\$1,439.95
3.625" Bore		
SS310007	'36-'47 Knucklehead	\$1,439.95
SS310009	'48-'68 Panhead	\$1,439.95
SS310013	'65-'69 Panhead Or Shovelhead	\$1,439.95
SS310022	'84-'99 Alt./Gen	\$1,449.95
SS310026	'84-'99 Alt./Gen Shovelhead	\$1,449.95



D. S&S® Oil Line Installation Kits

• Required when installing T124 engines or engines with S&S® crankcases in Dyna® and FL models.

SS310424	For '99-'05 Dyna® Models	\$299.95
SS310425	For '00-'06 FL Models	\$94.95



E. S&S® Billet Cover For Twin Cam

SS316516 Gearcover, Does Not Fit '99-'01 Engines That Require Cam Position Sensor
MSRP: \$499.95

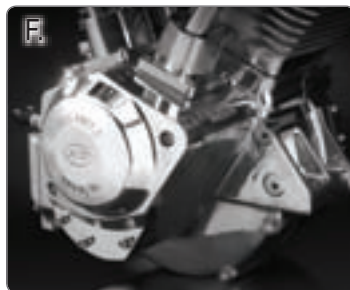

F. S&S® Billet Cover For Evolution®

SS310313 Fits Evolution® w/ Cam Position Sensor Ignition
MSRP: \$374.95

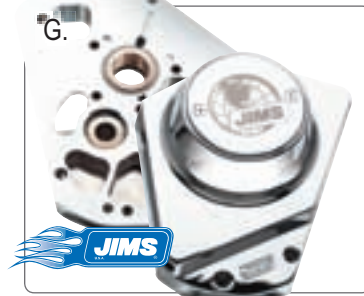

G. JIMS® Billet Cover For Evolution®

JM2413 Cam Cover, For Single Cam BT & '73-'92 BT & S&S® Chrome
MSRP: \$501.90

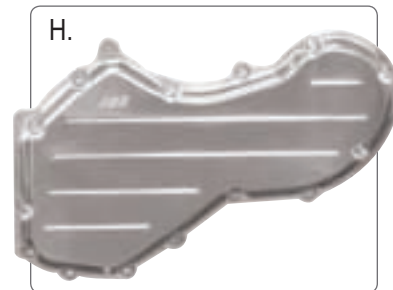

H. S&S® Billet Cover For Generator

SS310347 '36-'53 Stock Engines \$439.95
SS310349 '54-'68 Stock Engines \$439.95
SS310351 S&S® Generator \$439.95

I. Retro Conversion Kit For '66-'84 Shovelhead To Panhead

- Give your shovelhead engine the nostalgic look of a pan
- Improves performance at the same time
- Includes S&S® P-Series cylinder heads with rocker cradles, S&S® roller rocker arms, S&S® hydraulic tappets, billet tappet guides, Quickee pushrods, pushrod cover clips, and the required gaskets and hardware for assembly.
- Pan covers sold separately
- Pan covers have a shovelhead bolt pattern, making them compatible with any stock or aftermarket cylinder for 1966-'84 big twins
- They are designed to accept stock or S&S® o-ring style manifolds for shovelhead, and accept any exhaust system made to fit a shovel engine
- Heads come complete with valves and .590" lift valve springs.

PART	DESCRIPTION	MSRP
Retro Conversion Kits For '66-'84 BT		
SS1061070	Stock Bore	\$2,674.95
SS1061071	3.625" Bore	\$2,674.95
SS1061078	3.625" Bore Dual-Plugged	\$2,729.95
Pan Covers w/ Shovelhead Bolt Pattern		
SS1060919	Chrome	\$68.95

CONNECT SHOVEL
TO PANHEAD



B. S&S® Hot Setup® Kits

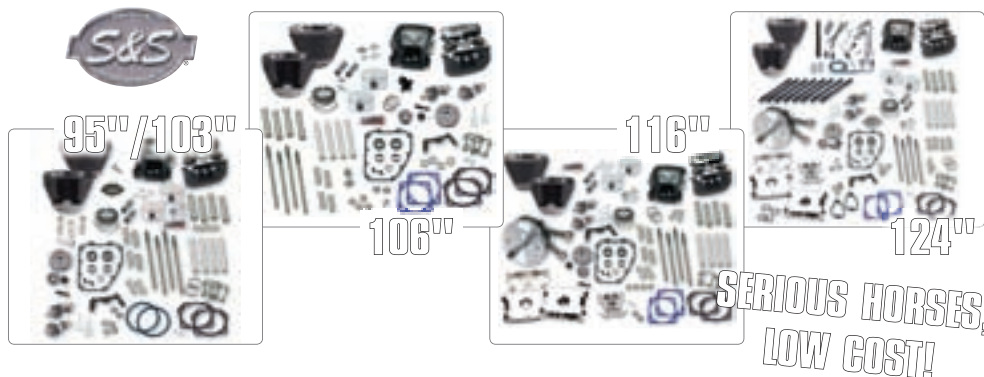

Hot Set Up® Kits For '99-later BT (Fuel Systems Separate, Listed Below)

PART	DESCRIPTION	MSRP
95" For: (Kits Available w/o Pistons & Cylinder Heads, Call For Details.)		
SS1060213	'99-'06 TC88®, Natural*	\$2,815.00
SS1060214	'99-'06 TC88®, Polished*	\$2,985.00
SS1060201	'06 Dyna®, Natural	\$2,885.00
SS1060202	'06 Dyna®, Black	\$2,970.00

*Excludes '06 Dyna®

103" For: (Available w/o Pistons & Cylinder Heads, Call For Details.)		
SS1060519	'07-Later 96" H-D®, Polished	\$2,875.00
SS1060520	'07-Later 96" H-D®, Black	\$3,045.00

106" For: (Available w/o Pistons & Cylinder Heads, Call For Details.)		
SS1060193	'99-'05 TC88®, Natural	\$3,995.00
SS1060194	'99-'05 TC88®, Black	\$4,080.00
SS1060195	'01-'05 TC88B®, Natural	\$4,035.00
SS1060196	'01-'05 TC88B®, Black	\$4,120.00
SS1060203	'07-Later TC96™, Natural	\$4,110.00
SS1060204	'07-Later TC96™, Black	\$4,195.00
SS1060103	'07-Later TC96B™, Natural	\$4,195.00
SS1060104	'07-Later TC96B™, Black	\$4,280.00

116" For: (Available w/o Pistons & Cylinder Heads, Call For Details.)		
SS1060197	'99-'05 TC88®, Natural	\$4,715.00
SS1060198	'99-'05 TC88®, Black	\$4,885.00
SS1060199	'01-'05 TC88B®, Natural	\$4,765.00
SS1060200	'01-'05 TC88B®, Black	\$4,935.00
SS1060205	'07-Later TC96™, Natural†	\$4,795.00
SS1060206	'07-Later TC96™, Black†	\$4,965.00
SS1060103	'07-Later TC96B™, Natural††	\$4,195.00
SS1060104	'07-Later TC96B™, Black††	\$4,280.00

† Includes '06 Dyna® †† Includes '07 Dyna®

124" For: (Available w/o Pistons & Cylinder Heads, Call For Details.)		
SS1060181	'99-'06 TC88®, Natural	\$5,325.00
SS1060183	'99-'06 TC88®, Black	\$5,495.00
SS1060185	'99-'06 TC88B®, Natural	\$5,385.00
SS1060187	'99-'06 TC88B®, Black	\$5,555.00
SS1060209	'07-Later TC96™, Natural†	\$5,355.00
SS1060210	'07-Later TC96™, Black†	\$5,525.00
SS1060172	'07-Later TC96B™, Natural††	\$1,764.95
SS1060173	'07-Later TC96B™, Black††	\$1,764.95

† Includes '06 Dyna® †† Includes '07 Dyna®

S&S® Fuel Systems For Hot Set Up® Kits

PART	DESCRIPTION	MSRP
Carbureted:		
SS110450	95", 103" Super G Carb, '99-'06	\$509.95
SS110451	106" Super G Carb Kit, '99-'05	\$529.95
SS1060874	106" Super G Carb Kit, '06	\$509.95
SS110466	116" Super G Carb Kit, '99-'06	\$529.95
SS110531	124" Super G Carb Kit, '99-'06	\$529.95

S&S® Variable Fuel Injection Modules:		
SS555006	Magneti Marelli®-Style, '95-'01	\$599.95
SS555090	Delphi®-Style, '01-Later	\$599.95

Single-Bore Tuned Induction (Optional):		
SS171005	95", 103", 106" & 124" , Chrome	\$324.95
SS171003	95", 103", 106" & 124" , Wrinkle Blk	\$259.95
SS171001	95", 103", 106" & 124" , Natural	\$239.95
SS171047	Bracket Kit, Stock	\$374.95
SS171046	Bracket Kit, 4 1/8" Bore	\$374.95

Single-Bore EFI Induction: (These systems do not contain an S&S® module. Intended for use with other programmable EFI modules. Single Bore Kits fit '01-'05 models.)

SS175080	95"-106" w/ Teardrop, '99-'01	\$1,099.95
SS175075	95"-106" w/ Teardrop, '01-'05	\$954.95
SS1061186	95"-106" w/ Teardrop, '06	\$929.95
SS175083	116" Teardrop Air Cleaner, '99-'01	\$1,099.9
SS175078	116" Teardrop Air Cleaner, '01-'05	\$954.95
SS1061187	116" Teardrop Air Cleaner, '06	\$929.95
SS175084	124" , 4 1/8" Bore w/ Desperado, '99-'01*	\$1,099.95
SS175079	124" , 4 1/8" Bore w/ Desperado, '01-'05*	\$954.95
SS175085	124" , 4 1/8" Bore w/ Desperado, '96-'07*	\$954.95
SS175082	124" , Stock Head w/ Teardrop '99-'01*	\$1,099.95
SS175077	124" , Stock Head w/ Teardrop, '01-'05*	\$954.95
SS175086	124" , Stock Head w/ Teardrop, '96-'07*	\$954.95

S&S® Hot Set Up® Kits For Sportster®



PART	DESCRIPTION	MSRP
74XLSS w/ Super Stock® Cylinder Heads For:		
SS900324	'86-'90 XL, Natural	\$1,964.95
SS900326	'86-'90 XL, Black	\$2,049.95
SS900325	'91-'03 XL, Natural	\$2,099.95
SS900327	'91-'03 XL, Black	\$2,184.95
89XL Sidewinder®/Stroker Kit, No Heads:		
SS323090	'86-'90 XL, Natural	\$2,629.95
SS323092	'86-'90 XL, Black	\$2,714.95
SS323091	'91-'03 XL, Natural	\$2,684.95
SS323093	'91-'03 XL, Black	\$2,769.95



Hot Set Up® Kits For '84-'99 BT

Kits also available w/o cylinder heads, call for details.

PART	DESCRIPTION	MSRP
80FLSS w/ Super Stock® Cylinder Heads For:		
SS900081	'84-'92 BT, Natural	\$1,719.95
SS900083	'84-'92 BT, Black	\$1,804.95
SS900084	'93-'99 BT, Natural	\$1,804.95
SS900082	'93-'99 BT, Black	\$1,719.95
89FLSS w/ Super Stock® Cylinder Heads For:		
SS900044	'84-'92 BT, Natural	\$2,499.95
SS900046	'84-'92 BT, Black	\$3,314.95
SS900045	'93-'99 BT, Natural	\$2,499.95
SS900047	'93-'99 BT, Black	\$2,584.95
96FLSS w/ Super Stock® Cylinder Heads For:		
SS900120	'84-'92 BT, Natural	\$3,149.95
SS900121	'84-'92 BT, Black	\$3,319.95
SS900122	'93-'99 BT, Natural	\$3,149.95
SS900123	'93-'99 BT, Black	\$3,319.95



Hot Set Up®/Stroker Kits For '55-'84 BT

PART	DESCRIPTION	MSRP
84" Stock Bore Stroker Hot Set Up Kit® For:		
SS322284	'55-'64	\$1,794.95
SS322285	'56	\$1,794.95
SS322286	'66-'69	\$1,804.95
SS322287	'70-'77	\$1,774.95
SS322289	'78-'84	\$1,774.95
93" Sidewinder® Big Bore Stroker Hot Set Up Kit® For:		
SS322265	'66-'69, Incl. Cylinders & Pistons	\$2,484.95
SS322266	'70-'72, Incl. Cylinders & Pistons	\$2,484.95
SS322267	'73-'77, Incl. Cylinders & Pistons	\$2,449.95
SS322268	'78-'84, Incl. Cylinders & Pistons	\$2,444.95



A. S&S® Sidewinder® Kits For '84-'99 BT

- For 80" stock engines and S&S® 89" stock bore strokers
- Engine life may vary based on modifications, call for details
- Includes: flywheels, cylinders, head & base gaskets, pistons, intake manifold, head bolts, pushrods & clips unless noted

PART	DESCRIPTION	MSRP
88" Does Not Include: Head Bolts		
SS917650	Natural	\$1,744.95
SS917651	Black	\$1,829.95
93" Does Not Include: Head Bolts		
SS917655	Natural	\$1,729.95
SS917656	Black	\$1,814.95
96" Does Not Include: Head Bolts, Intake Manifold, Pushrods		
SS917660	Natural	\$1,549.95
SS917661	Black	\$1,634.95
98" Does Not Include: Pushrod Clips		
SS917665	Natural	\$1,829.95
SS917666	Black	\$1,914.95
103" Includes All Items		
SS917670	Natural	\$1,829.95
SS917671	Black	\$1,914.95

D. S&S® Stock Bore Stroker Kits For '84-'99 BT



Pistons sold separately, call for details.

When ordering, please provide the following information: year of engine and type of crankcase. Extra cost options are pistons. Fits for:

SS322230	89", Carbureted	\$964.95
SS322146	89", Fuel Injected	\$964.95

G. S&S® Stock Bore Stroker Kits For '36-'84 BT

When ordering, please provide the following information: year of engine and type of crankcase. Extra cost options are pistons. Fits for:

SS322219	84", 8.25:1 CR '36-'53 BT	\$994.95
SS322220	84", 8.25:1 CR '58-'64 BT	\$1,024.95
SS322221	84", 8.25:1 CR '65-'69 BT	\$1,024.95
SS322222	84", 8.25:1 CR '70-'84 BT	\$1,004.95
SS322272	86", 8.5:1 CR '48-'53 BT	\$1,004.95
SS322106	86", 8.5:1 CR '58-'64 BT	\$1,039.95
SS322107	86", 8.5:1 CR '65-'69 BT	\$1,039.95
SS322108	86", 8.5:1 CR '70-'84 BT	\$1,019.95
SS322276	88", 9:1 CR '36-'53 BT	\$994.95
SS322256	88", 9:1 CR '58-'64 BT	\$1,024.95
SS322257	88", 9:1 CR '65-'69 BT	\$1,024.95
SS322258	88", 9:1 CR '70-'84 BT	\$1,004.95



B. S&S® Sidewinder® Kits For '66-'84 BT

- Includes: flywheels, cylinders, head & base gaskets, forged pistons, base nuts, head bolts, motor mount, pushrods & clips
- Cast piston option available, call for details
- Intake manifolds sold separately, call for details

PART	DESCRIPTION	MSRP
88" Does Not Include: Pushrod Clips		
SS919123	Gloss, '66-'69 BT	\$1,884.95
SS919124	Gloss, '70-'84 BT	\$1,864.95
SS919153	Wrinkle, '66-'69 BT	\$1,884.95
SS919154	Wrinkle, '70-'84 BT	\$1,864.95
93" Includes All Items		
SS919127	Gloss, '66-'69 BT	\$1,929.95
SS919128	Gloss, '70-'84 BT	\$1,914.95
SS919157	Wrinkle, '66-'69 BT	\$1,929.95
SS919158	Wrinkle, '70-'84 BT	\$1,914.95
93H Includes All Items		
SS919129	Gloss, '66-'69 BT	\$1,929.95
SS919130	Gloss, '70-'84 BT	\$1,914.95
SS919159	Wrinkle, '66-'69 BT	\$1,929.95
SS919160	Wrinkle, '70-'84 BT	\$1,914.95
96" Includes All Items		
SS919133	Gloss, '66-'69 BT	\$1,929.95
SS919134	Gloss, '70-'84 BT	\$1,914.95
SS919163	Wrinkle, '66-'69 BT	\$1,929.95
SS919164	Wrinkle, '70-'84 BT	\$1,914.95
98" Includes All Items		
SS919137	Gloss, '66-'69 BT	\$1,929.95
SS919138	Gloss, '70-'84 BT	\$1,914.95
SS919167	Wrinkle, '66-'69 BT	\$1,929.95
SS919168	Wrinkle, '70-'84 BT	\$1,914.95
103" Includes All Items		
SS919139	Gloss, '66-'69 BT	\$1,929.95
SS919140	Gloss, '70-'84 BT	\$1,914.95
SS919169	Wrinkle, '66-'69 BT	\$1,929.95
SS919170	Wrinkle, '70-'84 BT	\$1,914.95

E. JIMS® Series II Twin Cam Stroker Kit

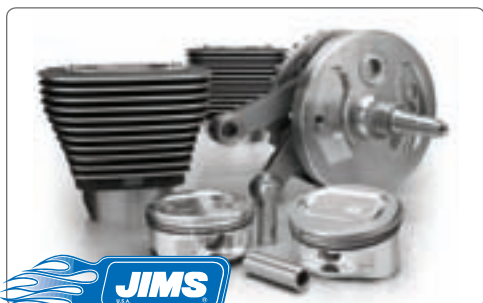

JIMS flywheel assemblies were designed for stock engine case bored to accommodate 4" bore cylinders. NOTE: You must order a gasket kit to reseal the engine. JIMS cylinders "blend" into the stock appearance of the motor and are available in silver or wrinkle black. All JIMS stroker kits have a new oiling jet design. Oiling jets are easily installed and ship with every kit.

JM1941	Series II Twin Cam Stroker Kit	\$2,308.15
--------	--------------------------------	------------



C. S&S® Sidewinder® Kits For '86-'03 XL

- Includes: flywheels, cylinders, head & base gaskets, forged pistons, intake manifold, head bolts, head mount, pushrods

PART	DESCRIPTION	MSRP
79" Does Not Include: Head Bolts, Head Mounts, Pushrods, Intake Manifold		
SS913002	Natural, '86-'03 XL	\$794.95
SS913901	Black, '86-'03 XL	\$879.95
93" Includes All Items		
SS913121	Natural, '86-'90 XL	\$2,174.95
SS913123	Natural, '91-'03 XL	\$2,224.95
SS913122	Black, '86-'90 XL	\$2,259.95
SS913124	Black, '91-'03 XL	\$2,309.95
103" Includes All Items		
SS913125	Natural, '86-'90 XL	\$2,214.95
SS913127	Natural, '91-'03 XL	\$2,274.95
SS913126	Black, '86-'90 XL	\$2,299.95
SS913128	Black, '91-'03 XL	\$2,359.95

F. S&S® Stock Bore Stroker For '72-'85 XL

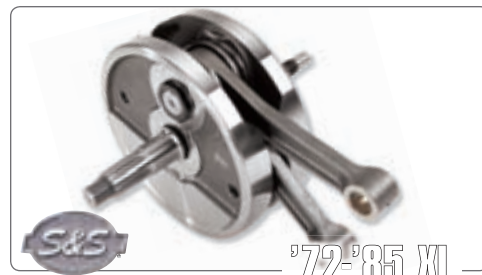

When ordering, please provide the following information: year of engine and type of crankcase. Extra cost options are pistons. Fits for:

SS323051	72", '72-'76 XL	\$1,084.95
SS323052	72", '77-'81 XL	\$1,089.95
SS323053	72", '81-'85 XL	\$1,124.95
SS323054	74", '72-'76 XL	\$1,084.95
SS323055	74", '77-'81 XL	\$1,089.95
SS323056	74", '81-'85 XL	\$1,124.95

H. S&S® Stock Bore Stroker Kit For Twin Cam



SS322490	106", For '99-'06 TC88® (Excludes Dyna®)	\$1,334.95
SS322491	106", For '00-'06 TC88B®	\$1,384.95
SS322294	106", For '06 Dyna® & '07 TC96™	\$1,344.95
SS1060127	106", For '07 TC96B™	\$1,394.95

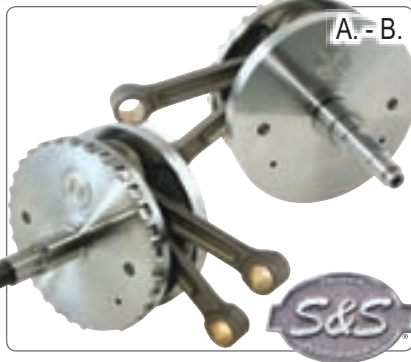

A. - B.

A. S&S® Flywheel Assemblies for Twin Cam 88® & Twin Cam 88B®

All flywheel assemblies are completely assembled with pinion shaft, sprocket shaft and connecting rods. Kit requires OEM #24004-03 for installation in '03-later cases. Kit requires OEM #24004-03 for installation in '06-Later Dyna™ Models. S&S® Connecting rods are not compatible with pistons from stock '07-later 96" engines. Includes fitments for:

PART	DESCRIPTION	MSRP	PART	DESCRIPTION	MSRP
88", 95", 100":					
SS322240	4" Stroke, For TC88®, Excl. '06 Dyna®	\$1,294.95	SS322242	4.5" Stroke, For TC88®, Excl. '06 Dyna®	\$1,294.95
SS322241	4" Stroke, For TC88B®, Excl. '06 Dyna®	\$1,344.95	SS322243	4.5" Stroke, For TC88B®, Excl. '06 Dyna®	\$1,344.95
SS322293	4" Stroke, For TC96™	\$1,344.95	SS322294	4.5" Stroke, For TC96™	\$1,344.95
93", 103", 110", 117":					
SS322312	4.375" Stroke, For TC88®, Excl. '06 Dyna®	\$1,294.95	SS322244	4.25" Stroke, For TC88®, Excl. '06 Dyna®	\$1,294.95
SS322314	4.375" Stroke, For TC88B®, Excl. '06 Dyna®	\$1,294.95	SS322245	4.25" Stroke, For TC88B®, Excl. '06 Dyna®	\$1,344.95
SS322310	4.375" Stroke, For TC96™	\$1,344.95	107":		
SS322311	4.375" Stroke, For TC96B™	\$1,394.95	SS322246	4.625" Stroke, For TC88®, Excl. '06 Dyna®	\$1,294.95
			SS322247	4.625" Stroke, For TC88B®, Excl. '06 Dyna®	\$1,344.95
			SS322295	4.625" Stroke, For TC96™	\$1,344.95
			SS322313	4.625" Stroke, For TC96B™	\$1,394.95



C.

B. S&S® Flywheel Assemblies for '36-'99 Big Twin

Big Twin Flywheel Assemblies are unassembled, unbalanced and do not include pinion shaft, sprocket shaft, connecting rods or pinion conversion kit. These are extra cost options. Please specify year and extra cost options when placing order.

SS322014	8.5" Dia. w/ 3 3/32" Stroke	\$399.95	SS322020	8.5" Dia. w/ 4 1/2" Stroke	\$399.95	SS322061	8.25" Dia. w/ 4 5/8" Stroke	\$399.95
SS322050	8.5" Dia. w/ 4 1/4" Stroke	\$399.95	SS322060	8.5" Dia. w/ 4 5/8" Stroke	\$399.95	SS322031	8.25" Dia. w/ 4 3/4" Stroke	\$399.95
SS322010	8.5" Dia. w/ 4 3/8" Stroke	\$399.95	SS322051	8.25" Dia. w/ 4 1/4" Stroke	\$399.95			

C. JIMS® Press Flywheel Assemblies for '84-Later Evolution® (8.5") Diameter

The strongest and most rigid crankshaft made thanks to the stiffness of the genuine OE Twin Cam crank pin and bearings. To maximize stiffness and reliability, each unit is forged using JIMS® "H" beam 4340 chrome moly connecting rods. Bare crankshafts require selection of pistons within the specified range to ensure correct flywheel balancing. Balanced and ready to use. See price list for kits without pistons.

PART	DESCRIPTION	MSRP	PART	DESCRIPTION	MSRP
JM1976	4 1/4" Strk., 3 1/2" Std. Bore, 10:1 CR	\$1,668.35	JM1982	4 5/8" Strk., 3 1/2" Std. Bore, 9.25:1 CR	\$1,668.35
JM1977	4 1/4" Strk., 3 1/2" +.005 Bore, 10:1 CR	\$1,668.35	JM1983	4 5/8" Strk., 3 1/2" +.005 Bore, 9.25:1 CR	\$1,668.35
JM1978	4 1/4" Strk., 3 1/2" +.010 Bore, 10:1 CR	\$1,668.35	JM1984	4 5/8" Strk., 3 1/2" +.010 Bore, 9.25:1 CR	\$1,668.35
JM1979	4 1/2" Strk., 3 1/2" Std. Bore, 10:1 CR	\$1,668.35	JM1985	4 5/8" Strk., 3 5/8" Std. Bore, 9.75:1 CR	\$1,668.35
JM1980	4 1/2" Strk., 3 1/2" +.005 Bore, 10:1 CR	\$1,668.35	JM1986	4 5/8" Strk., 3 5/8" +.005 Bore, 9.75:1 CR	\$1,668.35
JM1981	4 1/2" Strk., 3 1/2" +.010 Bore, 10:1 CR	\$1,668.35	JM1987	4 5/8" Strk., 3 5/8" +.010 Bore, 9.75:1 CR	\$1,668.35

D. S&S® Cams For '84-'99 BT



D.

PART	DESCRIPTION	MSRP
510V	80"-96" w/ up to 10:1 CR	
SS335124	238/252 Lift: .510"	\$174.95
520	80"-96" w/ 8.5:1 to 10:1 CR	
SS335073	220/232 Lift: .520"	\$174.95
561	80"-96" w/ 9.5:1 to 10.5:1 CR	
SS335076	252/256 Lift: .561"	\$174.95
585V	80"-96" w/ 10 to 10.5:1 CR	
SS335109	245/260 Lift: .585"	\$174.95
520	96" w/ 8.5 to 10.5:1 CR	
SS335073	220/232 Lift: .520"	\$174.95
640	Big-Inch w/ 10.5:1 to 11.5:1 CR	
SS335108	265/265 Lift: .640"	\$174.95
546	4" Bore w/ 9.1:1 to 10.1:1 CR	
SS335073	240/237 Lift: .546"	\$174.95
600	4" Bore w/ 10:1 to 10.5:1 CR	
SS335058	255/260 Lift: .600"	\$174.95
631	High-RPM w/ 11:1 to 12.1:1 CR	
SS335080	275/275 Lift: .630"	\$174.95

G. S&S® Cams For '86-'03 XL

PART	DESCRIPTION	MSRP
500	74"-89" w/ 9:1 to 10.5:1 CR	
	89"-100" w/ <9.5:1 CR	
SS335081	'86-'90 XL	\$289.95
SS335082	'91-'03 XL	\$289.95
555	74"-100" w/ 9.5:1 to 11:1 CR	
SS335083	'86-'90 XL	\$289.95
SS335084	'91-'03 XL	\$289.95
600	89"+ w/ 9.5:1 to 10.5:1 CR	
SS335125	'86-'90 XL	\$289.95
SS335126	'91-'03 XL	\$289.95

E. Crane Cams® Camshafts for Twin Cam



E.

Camshafts For TC88®	MSRP
CR13000	Heavy Bikes w/ Stock CR 226/236 Lift: .505" \$307.82
CR13001	Stock to 9.5:1 CR 236/242 Lift: .505" \$307.82
CR13002	Stock to 10.1:1 CR 242/252 Lift: .505" \$307.82
CR13003	88"-95" w/ 9.5:1+ CR 240/248 Lift: .570" \$307.82
CR13004	Modifieds w/ 10.5:1+ CR 254/260 Lift: .600" \$307.82
CR13005	Modifieds w/ 10.25:1+ CR 246/254 Lift: .619" \$307.82
Camshafts For TC96®	MSRP
CR16000	Heavy Bikes w/ Stock CR 226/236 Lift: .505" \$307.82
CR16001	Stock to 9.5:1 CR 236/242 Lift: .505" \$307.82
CR16002	Stock to 10.1:1 CR 242/252 Lift: .505" \$307.82
CR16003	88"-95" w/ 9.5:1+ CR 240/248 Lift: .570" \$307.82
CR16004	Modifieds w/ 10.5:1+ CR 254/260 Lift: .600" \$307.82
CR16005	Modifieds w/ 10.25:1+ CR 246/254 Lift: .619" \$307.82

F. Feuling™ Cam Plates



F.

- Increased oil flow and volume decreases engine temperature by up to 20°
- Use only FE7000/50 oil pumps with '99-'06 & FE7060/62 with '06-later
- Rear wheel power gains of 3 HP and 4 ft./lb. of torque can be achieved
- Eliminates the need to stretch the spring or use a shim
- Includes bearing retainer plate and hardware

PART	DESCRIPTION	MSRP
FE8000	Cam Plate For '99-'06 TC (Excludes '06 Dyna®), Gear Drive	\$389.00
FE8010	Cam Plate For '99-'06 TC (Excludes '06 Dyna®), Chain Drive	\$399.00
FE8015	Cam Plate For '06-Later TC & Dyna®	\$389.00
FE8018	Cam Plate Pressure Relief Valve, Spring (1)	\$9.99
FE8019	Cam Plate Pressure Relief Valves, Spring (6)	\$19.99
FE8020	Fastener Kit, For Feuling™ Oil Pumps, Black Oxide, 12-Point	\$39.95
FE9000	Cam Plate Pressure Relief Valve Removal & Install Tool	\$49.95
FE9010	Cam Plate Pressure Test Tool, Set Relief Valve, Pop-Off	\$199.00

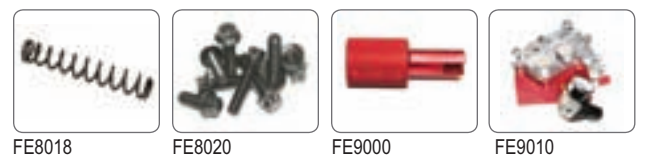

FE8018 FE8020 FE9000 FE9010

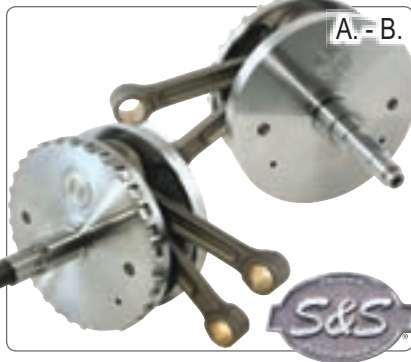

A. - B.

A. S&S® Flywheel Assemblies for Twin Cam 88® & Twin Cam 88B®

All flywheel assemblies are completely assembled with pinion shaft, sprocket shaft and connecting rods. Kit requires OEM #24004-03 for installation in '03-later cases. Kit requires OEM #24004-03 for installation in '06-Later Dyna™ Models. S&S® Connecting rods are not compatible with pistons from stock '07-later 96" engines. Includes fitments for:

PART	DESCRIPTION	MSRP	PART	DESCRIPTION	MSRP
88", 95", 100":					
SS322240	4" Stroke, For TC88®, Excl. '06 Dyna®	\$1,294.95	SS322242	4.5" Stroke, For TC88®, Excl. '06 Dyna®	\$1,294.95
SS322241	4" Stroke, For TC88B®, Excl. '06 Dyna®	\$1,344.95	SS322243	4.5" Stroke, For TC88B®, Excl. '06 Dyna®	\$1,344.95
SS322293	4" Stroke, For TC96™	\$1,344.95	SS322294	4.5" Stroke, For TC96™	\$1,344.95
93", 103", 110", 117":					
SS322312	4.375" Stroke, For TC88®, Excl. '06 Dyna®	\$1,294.95	SS322244	4.25" Stroke, For TC88®, Excl. '06 Dyna®	\$1,294.95
SS322314	4.375" Stroke, For TC88B®, Excl. '06 Dyna®	\$1,294.95	SS322245	4.25" Stroke, For TC88B®, Excl. '06 Dyna®	\$1,344.95
SS322310	4.375" Stroke, For TC96™	\$1,344.95	107":		
SS322311	4.375" Stroke, For TC96B™	\$1,394.95	SS322246	4.625" Stroke, For TC88®, Excl. '06 Dyna®	\$1,294.95
			SS322247	4.625" Stroke, For TC88B®, Excl. '06 Dyna®	\$1,344.95
			SS322295	4.625" Stroke, For TC96™	\$1,344.95
			SS322313	4.625" Stroke, For TC96B™	\$1,394.95



C.

B. S&S® Flywheel Assemblies for '36-'99 Big Twin

Big Twin Flywheel Assemblies are unassembled, unbalanced and do not include pinion shaft, sprocket shaft, connecting rods or pinion conversion kit. These are extra cost options. Please specify year and extra cost options when placing order.

SS322014	8.5" Dia. w/ 3 3/32" Stroke	\$399.95	SS322020	8.5" Dia. w/ 4 1/2" Stroke	\$399.95	SS322061	8.25" Dia. w/ 4 5/8" Stroke	\$399.95
SS322050	8.5" Dia. w/ 4 1/4" Stroke	\$399.95	SS322060	8.5" Dia. w/ 4 5/8" Stroke	\$399.95	SS322031	8.25" Dia. w/ 4 3/4" Stroke	\$399.95
SS322010	8.5" Dia. w/ 4 3/8" Stroke	\$399.95	SS322051	8.25" Dia. w/ 4 1/4" Stroke	\$399.95			

C. JIMS® Press Flywheel Assemblies for '84-Later Evolution® (8.5") Diameter

The strongest and most rigid crankshaft made thanks to the stiffness of the genuine OE Twin Cam crank pin and bearings. To maximize stiffness and reliability, each unit is forged using JIMS® "H" beam 4340 chrome moly connecting rods. Bare crankshafts require selection of pistons within the specified range to ensure correct flywheel balancing. Balanced and ready to use. See price list for kits without pistons.

PART	DESCRIPTION	MSRP	PART	DESCRIPTION	MSRP
JM1976	4 1/4" Strk., 3 1/2" Std. Bore, 10:1 CR	\$1,668.35	JM1982	4 5/8" Strk., 3 1/2" Std. Bore, 9.25:1 CR	\$1,668.35
JM1977	4 1/4" Strk., 3 1/2" +.005 Bore, 10:1 CR	\$1,668.35	JM1983	4 5/8" Strk., 3 1/2" +.005 Bore, 9.25:1 CR	\$1,668.35
JM1978	4 1/4" Strk., 3 1/2" +.010 Bore, 10:1 CR	\$1,668.35	JM1984	4 5/8" Strk., 3 1/2" +.010 Bore, 9.25:1 CR	\$1,668.35
JM1979	4 1/2" Strk., 3 1/2" Std. Bore, 10:1 CR	\$1,668.35	JM1985	4 5/8" Strk., 3 5/8" Std. Bore, 9.75:1 CR	\$1,668.35
JM1980	4 1/2" Strk., 3 1/2" +.005 Bore, 10:1 CR	\$1,668.35	JM1986	4 5/8" Strk., 3 5/8" +.005 Bore, 9.75:1 CR	\$1,668.35
JM1981	4 1/2" Strk., 3 1/2" +.010 Bore, 10:1 CR	\$1,668.35	JM1987	4 5/8" Strk., 3 5/8" +.010 Bore, 9.75:1 CR	\$1,668.35

D. S&S® Cams for '84-'99 BT



D.

PART	DESCRIPTION	MSRP
510V	80"-96" w/ up to 10:1 CR	
SS335124	238/252 Lift: .510"	\$174.95
520	80"-96" w/ 8.5:1 to 10:1 CR	
SS335073	220/232 Lift: .520"	\$174.95
561	80"-96" w/ 9.5:1 to 10.5:1 CR	
SS335076	252/256 Lift: .561"	\$174.95
585V	80"-96" w/ 10 to 10.5:1 CR	
SS335109	245/260 Lift: .585"	\$174.95
520	96" w/ 8.5 to 10.5:1 CR	
SS335073	220/232 Lift: .520"	\$174.95
640	Big-Inch w/ 10.5:1 to 11.5:1 CR	
SS335108	265/265 Lift: .640"	\$174.95
546	4" Bore w/ 9.1:1 to 10.1:1 CR	
SS335073	240/237 Lift: .546"	\$174.95
600	4" Bore w/ 10:1 to 10.5:1 CR	
SS335058	255/260 Lift: .600"	\$174.95
631	High-RPM w/ 11:1 to 12.1:1 CR	
SS335080	275/275 Lift: .630"	\$174.95

G. S&S® Cams for '86-'03 XL

PART	DESCRIPTION	MSRP
500	74"-89" w/ 9:1 to 10.5:1 CR	
	89"-100" w/ <9.5:1 CR	
SS335081	'86-'90 XL	\$289.95
SS335082	'91-'03 XL	\$289.95
555	74"-100" w/ 9.5:1 to 11:1 CR	
SS335083	'86-'90 XL	\$289.95
SS335084	'91-'03 XL	\$289.95
600	89"+ w/ 9.5:1 to 10.5:1 CR	
SS335125	'86-'90 XL	\$289.95
SS335126	'91-'03 XL	\$289.95

E. Crane Cams® Camshafts for Twin Cam



E.

Camshafts For TC88®	MSRP
CR13000	Heavy Bikes w/ Stock CR 226/236 Lift: .505" \$307.82
CR13001	Stock to 9.5:1 CR 236/242 Lift: .505" \$307.82
CR13002	Stock to 10.1:1 CR 242/252 Lift: .505" \$307.82
CR13003	88"-95" w/ 9.5:1+ CR 240/248 Lift: .570" \$307.82
CR13004	Modifieds w/ 10.5:1+ CR 254/260 Lift: .600" \$307.82
CR13005	Modifieds w/ 10.25:1+ CR 246/254 Lift: .619" \$307.82
Camshafts For TC96®	MSRP
CR16000	Heavy Bikes w/ Stock CR 226/236 Lift: .505" \$307.82
CR16001	Stock to 9.5:1 CR 236/242 Lift: .505" \$307.82
CR16002	Stock to 10.1:1 CR 242/252 Lift: .505" \$307.82
CR16003	88"-95" w/ 9.5:1+ CR 240/248 Lift: .570" \$307.82
CR16004	Modifieds w/ 10.5:1+ CR 254/260 Lift: .600" \$307.82
CR16005	Modifieds w/ 10.25:1+ CR 246/254 Lift: .619" \$307.82

F. Feuling™ Cam Plates

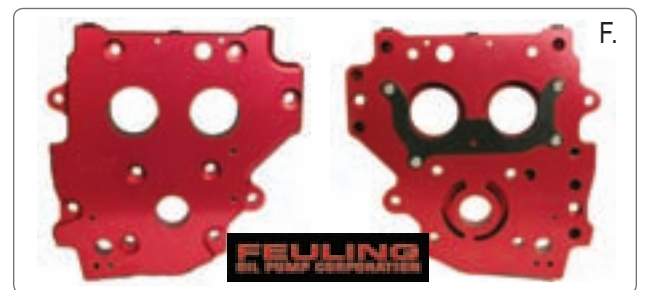

F.

- Increased oil flow and volume decreases engine temperature by up to 20°
- Use only FE7000/50 oil pumps with '99-'06 & FE7060/62 with '06-later
- Rear wheel power gains of 3 HP and 4 ft./lb. of torque can be achieved
- Eliminates the need to stretch the spring or use a shim
- Includes bearing retainer plate and hardware

PART	DESCRIPTION	MSRP
FE8000	Cam Plate For '99-'06 TC (Excludes '06 Dyna®), Gear Drive	\$389.00
FE8010	Cam Plate For '99-'06 TC (Excludes '06 Dyna®), Chain Drive	\$399.00
FE8015	Cam Plate For '06-Later TC & Dyna®	\$389.00
FE8018	Cam Plate Pressure Relief Valve, Spring (1)	\$9.99
FE8019	Cam Plate Pressure Relief Valves, Spring (6)	\$19.99
FE8020	Fastener Kit, For Feuling™ Oil Pumps, Black Oxide, 12-Point	\$39.95
FE9000	Cam Plate Pressure Relief Valve Removal & Install Tool	\$49.95
FE9010	Cam Plate Pressure Test Tool, Set Relief Valve, Pop-Off	\$199.00



FE8018 FE8020 FE9000 FE9010



A.

A. Crane Cams® Tappets & Pushrods For '66-'84 Shovelhead

- Precision machined and heat treated steel tappet bodies reduce the weight and improve the valve train geometry
- Pushrod seat is relocated to decrease the tappet guide block wear
- Oversize tappets are available to recondition worn tappet blocks

- Pushrods are included with each kit to ensure that a matched assembly will provide top performance and durability
- Pushrods are made from aircraft grade seamless steel tubing
- This kit requires the removal of the top end or the camshaft to install

PART	DESCRIPTION	MSRP
Kits w/ Mechanical Tappets:		
CR31010	Roller Tappets Only, 2-Pack	\$91.86
CR31000	Tappets & Adjust. Pushrods	\$273.70
CR31001	Tappets & Adjust. Pushrods, Stoker Length	\$273.70
CR31005	Tappet & Non-Adjust. Pushrod Kit	\$272.14
CR31015	Adjustable Mechanical Tappet Only, 2-Pack	\$119.27
CR31006	Adjust. Tappet & Non-Adjust. Pushrod Kit, Stoker Length	\$272.14

PART	DESCRIPTION	MSRP
Kits w/ Hydraulic Tappets & Adjustable Pushrods:		
CR31013	Hydraulic Roller Tappets Only, 2-Pack	\$228.58
CR31003	Tappets & Pushrods For 60"-80"	\$529.40
CR31004	Tappets & Pushrods For 60"-80", Stoker Length	\$529.40



B.

B. Crane Cams® Mechanical Tappet Conversion Kit For '66-'84 Shovelhead

- Convert your existing hydraulic tappets to mechanical for weight savings and high RPM operation
- This kit will relocate the pushrod seat height for better valve train geometry and less tappet guide block wear
- This kit does not require machining to install and includes adjustable pushrods
- A new pushrod seat assembly and plug prevents oil from entering the hollow tappet body, for a 25% weight savings
- Requires the removal of the top end or the camshaft to install

PART	DESCRIPTION	MSRP
CR31100	Mechanical Tappet Conversion Kit w/ Adjustable Pushrods, 4-Pack	\$139.84
CR31101	Mechanical Tappet Conversion Kit w/ Stoker-Length Adjustable Pushrods	\$139.84



C.

C. JIMS® Tappet Blocks & Covers

- Used in record breaking drag bikes world wide
- The absolute latest in tappet block design to eliminate all possible oil leakage and true precision fitment to cam lobe for the ultimate in tappet roller life
- "Low Rider" bore angles and 30 grams lighter than OE make them winners
- Recommended use of JM1094 tappets with standard billet lifter blocks
- Billet Lifter Block Covers have extra smooth lines and the absolute best chrome
- Covers come with gaskets and chrome hardware
- Use with JIMS® tappets — replaces OEM #25369-01

PART	DESCRIPTION	MSRP
JM1093B	Powerglide™ Billet Tappet Blocks For Evolution®	\$816.45
JM1094	Billet 7075-T651 Blocks For '84-'99 Evolution®	\$371.85
JM1043	Billet Lifter Blocks For Twin Cam, Chrome	\$166.90



D.

D. Fast Times™ Pushrods

CC7002K	For BT	\$125.96
CC7013K	For Twin Cam	\$123.59



E.

E. Crane Cams® Pushrods

For TC88® & TC96®, Adjustable, 4-Packs		
CR40021	Chrome Moly Steel	\$97.35
CR40022	Ultra-Lightweight	\$104.97
For '66-'84 BT, Adjustable, 4-Packs		
CR40009	Adjustable Pushrods Only	\$97.35
CR40010	Use w/ Mech. Tappets	\$97.35
CR40011	Stroker-Length	\$97.35
CR40012	Mechanical, Stroker-Length	\$97.35
CR40014	Non-Adjustable Pushrods Only	\$97.35
CR40015	Stroker-Length	\$97.35
For '66-'84 BT, Non-Adjustable, 4-Packs		
CR40018	Chrome Moly Steel	\$97.35
CR40019	Chrome Moly, Long Stroke	\$97.35
For '86-'90 XL w/ Evolution®, Adjustable, 4-Pack		
CR40020	Chrome Moly Steel	\$97.35
CR40023	For Collapsible Tubes	\$97.35



F.

F. Feuling™ Adjustable Pushrods

- Increased rigidity for higher engine RPM, horsepower and torque output
- Pushrods are 7/16" chrome moly with .095 or .120 wall thickness.
- Separate pushrods for intake and exhaust allow for minimal adjustment
- Exceeds the needs for performance engines
- Use with hydraulic or solid lifters.

For '99-'07 TC	
FE4065	.095 Wall Thickness \$199.00
FE4075	Shorty, .120, Use w/ FE4060 \$219.00
FE4070	Race, .120 Wall Thickness \$219.00
For '85-'99 BT	
FE4077	.095 Wall Thickness \$199.00
FE4080	Race, .120 Wall \$219.00



G.

G. S&S® Quickee Pushrods

- Unique threaded adjuster screws into the pushrod until the threads disengage
- Adjuster simply slides into the pushrod, making installation and removal a snap
- Once in place, a locknut prevents the adjuster from moving.
- Fitments For '64-Later BT
- See MCAAdvantages.com for complete fitment information

H. S&S® Pushrods

- Made from .25" chrome moly tubing
- Fits '84-'99 Evolution®/XL and Twin Cams
- See MCAAdvantages.com



I. JIMS® Billet Pushrod Cover Sets

- Unique clip that looks like a complete tube
 - Single push-pull spring type function.
 - Requires other JIMS® parts, call for details
- | | | |
|--------|---------------------------|----------|
| JM3002 | For '84-'99 OE & After BT | \$285.70 |
|--------|---------------------------|----------|

ENGINE
 FUEL SYSTEMS
 EXHAUST
 ELECTRICAL
 DRIVETRAIN
 WHEELS
 SUSPENSION
 SHEETMETAL
 FRAMES
 CONTROLS
 LIGHTING
 BAGGERS
 TOOLS
 APPAREL

A. JIMS® Roller Rockers

- JIMS® roller rockers reduce friction in the valvetrain and provide more horsepower and less heat in the top end
- Cast from 4340 chrome moly steel and heat treated
- 660 bronze bushing fit for the best wear resistance and oil control
- Roller tip made from bearing grade material to reduce guide wear and galling

Roller Rockers, Stock Ratio

JM1045RR	For '84-Later BT/TC/S&S®, '86-Later XL, '87-Later Buell®	\$494.20
JM1761183	Shaft For JM1045RR & Similar Fits	\$18.25



B.



CRANE
Cams



B. Crane Cams® Roller Rockers

- Oil metering system lubricates the fulcrum and roller tip for cooler operation
- Bushing fulcrum for long term performance and reliability
- Use the original equipment rocker arm shafts, fits with no machining
- Made from 4140 alloy steel, precision investment cast for greater strength, truer rocker arm ratio, and improved rocker geometry

PART	DESCRIPTION	MSRP
CR41015	For '99-Later TC88®/'84-'99 Evolution® & '86-Later Evolution® XL883 & XL1200 Stock Ratio, Bushing Style	\$488.23
CR41020	For '99-Later TC88®/'84-'99 Evolution® & '86-Later Evolution® XL883 & XL1200 1.75:1 Ratio, Bushing Style	\$488.23
CR41100	Replacement Front Roller Kit, 4-Pack	\$15.72
CR41104	Rocker Arm Shafts For '84-Later BT & '86-Later XL	\$77.88

C.

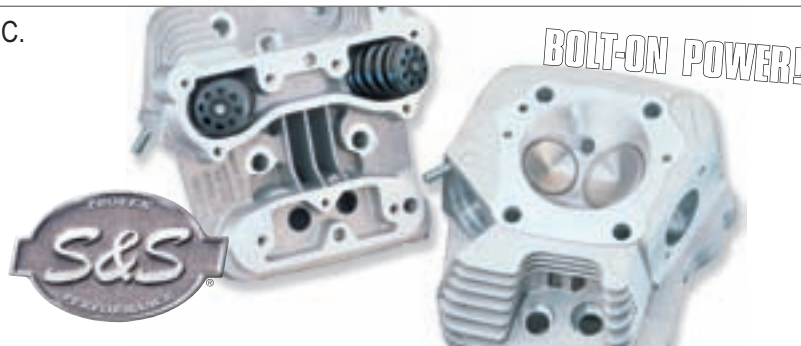

C. S&S® Super Stock® Cylinder Head Kits For '84-Later

Kits for Evolution® and Twin Cam® include heads only. Extra cost options are manifold, head gaskets, base gaskets, rocker cover gaskets, pistons, rocker covers, compression releases and head bolts.

PART	DESCRIPTION	MSRP	Cylinder Head Kits For '84-99 BT
Head Kits For '99-Later BT			
Requires S&S® Die-Cast TC Rocker Covers			
SS901171	79cc, Natural	\$1,169.95	SS901504 3 1/2" or 3 5/8", Black \$979.95
SS901173	79cc, Black	\$1,254.95	SS901004 3 1/2" or 3 5/8", Nat. \$894.95
SS901105	89cc, Natural	\$1,169.95	SS901091 3 1/2" or 3 5/8", Pol \$1,239.95
SS901106	89cc, Black	\$1,254.95	SS901070 4", 92cc, Polished \$1,299.95
SS901086	4 1/8", 91cc, Natural	\$1,244.95	SS901009 4", 92cc, Natural \$954.95
SS901087	4 1/8", 91cc, Black	\$1,329.95	SS901509 4", 92cc, Black \$1,039.95
			SS901071 4", 84cc, Polished \$1,299.95
			SS901015 4", 84cc, Natural \$1,039.95
			SS901515 4", 84cc, Black \$1,039.95

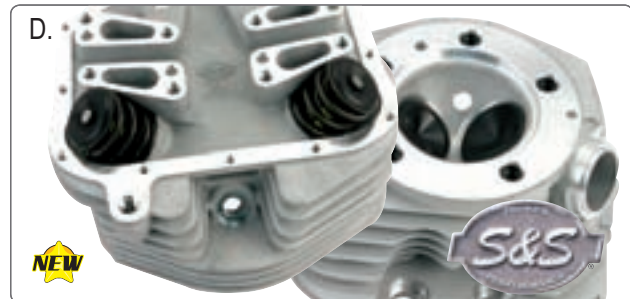

D. S&S® Panhead-Style Head Kits For Shovelhead or P-Series

- Replacements for P-Series engines, or for most shovelhead engines to give a nostalgic look and a performance boost over stock
- Stock shovelhead bolt pattern
- Intake ports accept o-ring manifolds for shovels — the exhaust ports will bolt up to any exhaust system for a shovel engine
- A special S&S rocker cradle is required to support the rocker arms
- Will not fit on stock panhead cylinders
- Complete kits include valves and springs, heads also available separate and bare

PART	DESCRIPTION	MSRP
SS1060414	Stock Bore, Single Plug, Silver	\$1,199.95
SS1060417	3.625" Bore, Single Plug, Silver	\$1,199.95
SS1060420	3.625" Bore, Dual Plug, Silver	\$1,259.95

E. Edelbrock® 95" EFI Power Package

- Designed for '01-Later Softail®, '04-'05 Dyna® and '02-Later tourers using 91 octane fuel with stock throttle body and Delphi® ECU.
- Edelbrock® CNC ported heads are the heart of the package—to give the gut-wrenching power that every rider wants.
- Includes Edelbrock® cylinder heads; Edelbrock® Performer RPM Chain or gear driven camshafts; Edelbrock®/JE pistons (10.25:1), rings, wrist pins and pin locks for 95 cu. in. motor; all necessary gaskets; adjustable pushrods; EFI intake manifold for stock throttle body; high-flow air cleaner and fuel calibrations for 30-plus pipes.* More calibrations at Edelbrock.com.

PART	DESCRIPTION	MSRP
EFI Power Package, Chain-Driven Cams**		
ED30204	Grey Powdercoated Finish Heads	\$2,614.95
ED30244	Black Powdercoated Heads	\$2,614.95
ED30804	Polished Heads	\$3,005.95
EFI Power Package, Gear-Driven Cams***		
ED30205	Grey Powdercoated Heads	\$2,647.95
ED30245	Black Powdercoated Heads	\$2,647.95
ED30805	Polished Heads	\$3,038.95

*Downloading calibrations into an ECU requires software tuning kit.

**Cam sets require S&S® Gasket Kit #SS335163.

***S&S® 4-Gear Cam Drive Set (#SS334275) required for installation w/ Gear-Driven Cam Sets.

F.



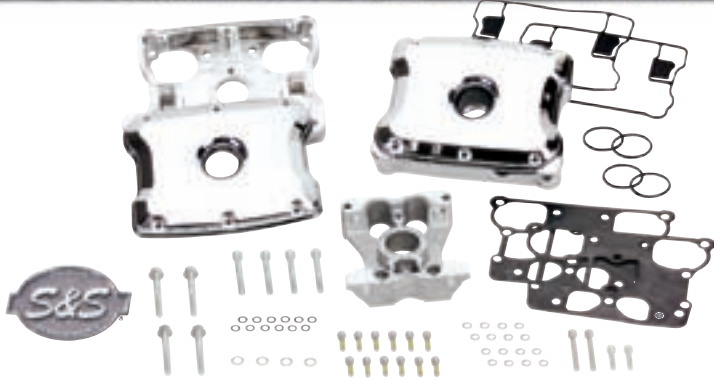

B.

A. JIMS® Shovelhead Valvetrain Clean Up Kit (Not Shown)

This totally engineered kit enables shovelhead top ends to oil like an Evolution®. Includes special powerglide tappet, worksaver pushrods, tappet blocks, roller rocker arms, two tappet block gaskets and an easy to follow instruction sheet.

PART	DESCRIPTION	MSRP
JM1046	Shovelhead Valvetrain Clean Up Kit	\$1,226.95

B. S&S® Rocker Covers

PART	DESCRIPTION	MSRP
SS904305	Billet, Polished, For '66-'84 BT, Leak-Free O-Ring	\$724.95
SS904050	Billet, Chrome, For '84-'99 BT, Leak-Free O-Ring	\$899.95
SS904095	Die Cast, Chrome, For '84-'99 BT, Leak-Free O-Ring	\$594.95
SS904110	Die Cast, Chrome, For '99-Later Twin Cam 88°	\$594.95



C.

C. Stampede™ Head Bolt Covers

Finish that totally customized look with these head bolt covers. Utilizes set screw for fitment. Available as set of four.

PART	DESCRIPTION	MSRP
ST21HBCB	For Evolution®, Black Powdercoat Aluminum	\$79.99
ST21HBCBS	For S&S®, Black Powdercoat Aluminum	\$69.99
ST21HBCE	For Evolution®, Polished Aluminum	\$59.99
ST21HBCE	For S&S®, Polished Aluminum	\$54.99

D. Crime Scene Choppers Brass Head Bolt Covers

- Lend a cool retro flair to any ride
- Slip over the existing head bolts and secure with the hideable set screw
- CNC machined out of brass billet, these are provided with a fine machined finish

PART	DESCRIPTION	MSRP
CSC801	For Evolution® Or Twin Cam, Set of 4	\$59.00



E.

E. D&M Custom Cycle Breather Bolt Kits

These universal breather bolts are 3.25" long for cutting to custom length. Available in three sizes with button or pointed head. Washers and spacers included.

PART	DESCRIPTION	MSRP	PART	DESCRIPTION	MSRP
Button Head For:					
DM5800K	1/2"-13 Evolution®	\$66.53	Pointed Head		
DM5900K	3/8"-16 Twin Cam	\$66.53	DM5500K	1/2"-13 Evolution®	\$66.53
DM6000K	5/16"-18 S&S®	\$66.53	DM5600K	3/8"-16 Twin Cam	\$66.53
			DM5700K	5/16"-18 S&S®	\$66.53

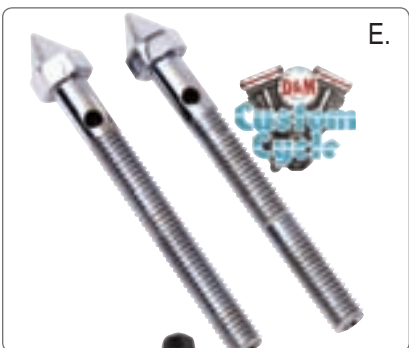

F. Spyke® Krank Vent System

Krank Vents help prevent blown gaskets, weeping and actually increase horsepower by regulating the proper amount of vacuum in the crankcase at all RPM ranges.

PART	DESCRIPTION	MSRP
SPKVSS	S&S®, Screamin' Eagle® w/ Banjo Bolts	\$89.99
SPKVSE	Screamin' Eagle® w/ Chrome Pipe Adapter & Inline Apps	\$89.99
SPKVXL	Sportster® (Backing Plate Required)	\$99.99
SPKVB	Big Twin (OEM Carb, Backing Plate & Filter Element)	\$99.99
SPKVTC	Twin Cam (Set Of 2)	\$159.99
SPKVEV	Evolution® Head Breather (Set Of 2)	\$159.99
SPKVB	Buell® & Special Applications Head Breather	Call

Bottom Breathers:

SPKVCC	All OEM & Aftermarket Cases w/ Timed Breather Ports, Early XL's On Cam Cover, 1/4 NPT Input Thread	
SPKVS	Universal	\$115.00
SPKVSM	Universal w/ Mount	\$115.00
SPKVF	Krank Vent Filter For SPKVS Or SPKVSM	\$24.22

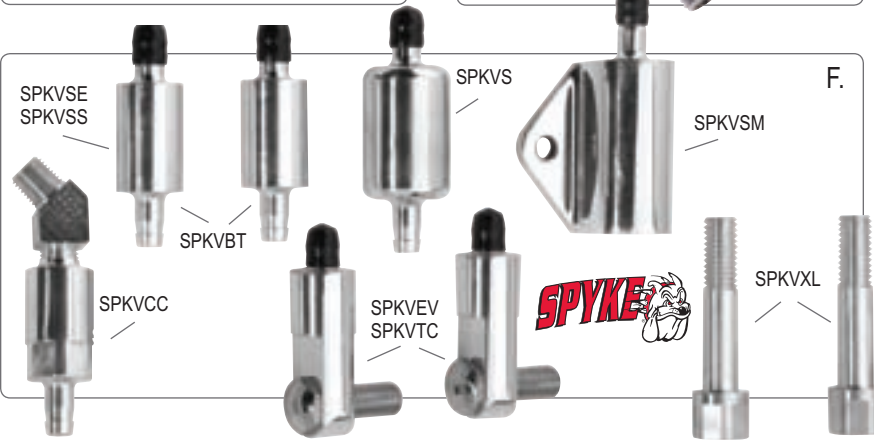

G.

G. S&S® Crankcase Breather Valves

Eliminate oil carry over in Twin Cam and Evolution® engines.

PART	DESCRIPTION	MSRP
SS312096	Crankcase Breather Reed Valve, '84-'99 BT	\$89.95
SS312100	Crankcase Reed Valve, .030" Over, '84-'99 BT	\$99.95
SS312070	Crankcase Breather Valve, '99-'02 BT	\$99.95
SS312071	Crankcase Breather Valve, '03-Later BT	\$99.95



ENGINE
 FUEL SYSTEMS
 EXHAUST
 ELECTRICAL
 DRIVETRAIN
 WHEELS
 SUSPENSION
 SHEETMETAL
 FRAMES
 CONTROLS
 LIGHTING
 BAGGERS
 TOOLS
 APPAREL

A. JIMS® Oversized Breather Gears For BT

JIMS® replacement breather valve gear is made +.030" oversize to correct a damaged breather valve hole. **Provides precise control of exhausting crankcase pressure.** Made from the finest aerospace quality steel.

PART	DESCRIPTION	MSRP
JM2337	For L77-'79 BT w / Single Cam (Use Tool JM1706)	\$78.85
JM2338	For '48-E'77 BT w/ Single Cam (Use Tool JM1706)	\$78.85

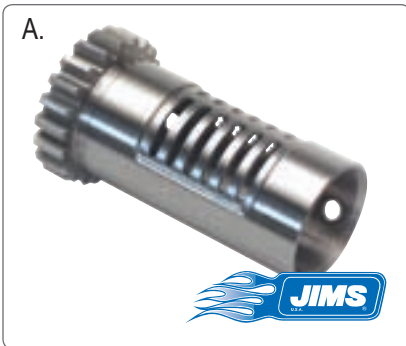

B. Stampede™ Oil Foil Blow-By Stopper

- Works as an oil collector, allowing removal of the bottom reservoir to drain it
- Internally baffled with breather filter included
- Can be used with Spyke® Krank vents or other PCV valves
- 5" overall height

PART	DESCRIPTION	MSRP
STRWFC	Stampede™ Oil Foil, Chrome	\$149.99
STRWFP	Stampede™ Oil Foil, Polished	\$129.99



C. Doherty Machine MYSTFREE™ Blow-By Stopper

- Designed specifically for the TC88® to stop the blowby mist emitted from an engine's breather system — **GUARANTEED!**
- Utilizes a two-chamber design to capture and return emitted oil so that no oil residue ever reaches the raised air outlet located on the top front portion of the MYSTFREE
- Installation requires only the removal of the six bolts securing each rocker box

PART	DESCRIPTION	MSRP
DH1999	MYSTFREE For Twin Cam 88®	\$229.95

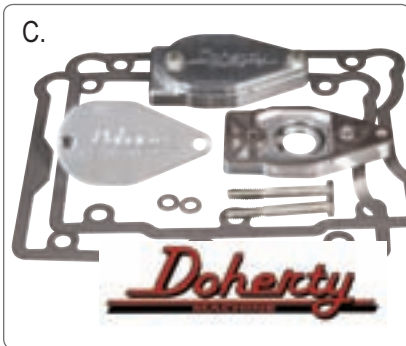

D. Yankee Engineuity Auxiliary Scavenger Oil Pump

PART	DESCRIPTION	MSRP
YESP01	For '70-'99 Big Twin and '70-Later XL	\$375.00

E. JIMS® Billet Oil Pumps

Increase in oil return (scavenge) volume over stock pumps, increases horsepower by decreasing drag on the flywheels and other rotating parts.

PART	DESCRIPTION	MSRP
JM1752	Billet Oil Pump For '92-'99 BT	\$402.55
JM1755	Billet Oil Pump For '73-'91 BT	\$402.55

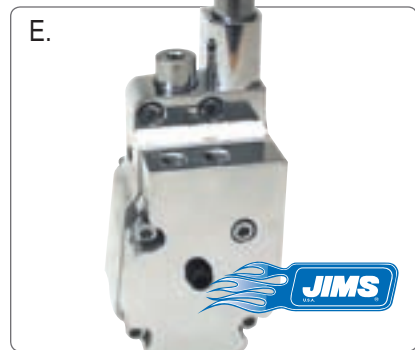

F. S&S® High Volume High Pressure Oil Pumps, '92-'00 BT

PART	DESCRIPTION	MSRP
SS316208	Pump w/ Universal Cover	\$359.95
SS316209	Pump w/ Standard Cover	\$359.95
SS316302	w/ Univ. Cover & Gears	\$469.95
SS316298	w/ Std. Cover & Gears	\$469.95

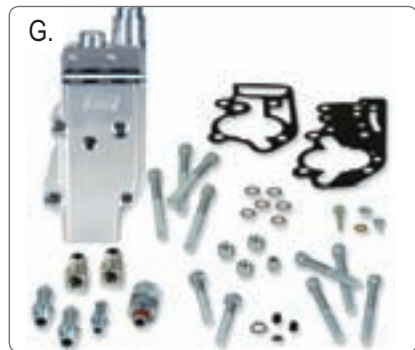

G. S&S® Billet Oil Pumps

PART	DESCRIPTION	MSRP	PART	DESCRIPTION	MSRP
SS316200	'36-'72 BT	\$294.95	SS316295	'78-'91 BT	
SS316203	'73-'91 BT	\$294.95		w/ Opt. Gears	\$399.95
SS316206	'92-'99 BT	\$294.95	SS316296	'92-'99 BT w/ Opt. Gears & Pre-'89 Pinion Shaft Only	\$399.95
SS316293	'54-'69 BT w/ Opt. Gears	\$399.95			
SS316294	'70-'77 BT w/ Opt. Gears	\$399.95			

H. Feuling™ Oil Pumps For Twin Cam

- **Increases oil pressure for cooler oil & engine temperatures while eliminating blow-by and wet sump with 60% more scavenge volume**
- Oily air cleaners are no longer a problem!
- Race models have even tighter tolerances and the harder 7075 aluminum alloy
- Used with the Feuling™ Cam Plate, results show a 3 HP gain!

PART	DESCRIPTION	MSRP
FE7000	High Vol. Pump For '99-'06 TC, Excludes '06 Dyna®	\$425.00
FE7050	High Vol. Race Pump For '99-'06 TC, Excludes '06 Dyna®	\$525.00
FE7062	High Vol. Race Pump For '07-Later TC & '06-Later Dyna®	\$525.00
FE7001	Oil Pump Rebuild Kit, For FE7000 & 7050 Oil Pumps	\$22.95
FE7061	Oil Pump Rebuild Kit, For FE7060 Oil Pump	\$22.95





A. Crime Scene Choppers Oil Filter Mount & Motor Mount

- Combines the top motor and Vendetta oil filter mount for a super clean installation
- Made from TIG welded steel, triple chrome plated
- Top motor mount includes stainless hardware
- Use with the Crime Scene Choppers Vendetta Oil Filter for maximum impact!

PART	DESCRIPTION	MSRP
CSC804	Steel Motor Mount Only, 80"-124" Engines, Chrome	\$99.00
CSC805	Steel Oil Filter Mount Bracket, Chrome	\$79.00

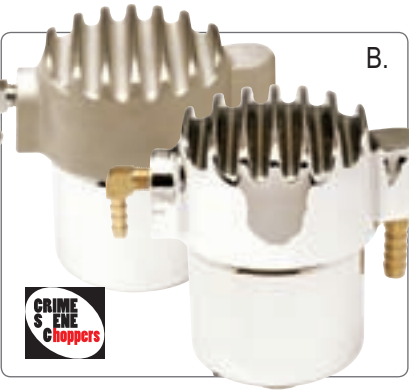

B. Crime Scene Choppers Vendetta Oil Filter

- Styling to match their popular oil tanks for a cool retro look
- Oriented to match a stock Panhead filter with chrome late model spin on filter
- Mount it anywhere or hang it in the breeze
- Complete with chrome K&N® filter and fittings, accepts filters with M1.5-16 thread

PART	DESCRIPTION	MSRP
CSC604	Mount, Chrome	\$298.00
CSC603	Mount, Satin w/ Highlight Fins	\$218.00



C. Engine Sentry™

- Protects engines from particles 20 times thicker than oil that wear on cylinders
- Powerful nickel-coated magnet inserted into any spin-on oil filter holds the steel shavings that trap damaging sludge, salt, carbon, nickel, chromium, copper, aluminum, and magnesium
- Proven to extend engine life, cool oil temps, increase lubricity, and improve filter and oil performance. Install Engine Sentry™ with each oil change

PART	DESCRIPTION	MSRP
MS010	Engine Sentry, 10-Pack	\$69.50/\$6.95 Piece



D. Stampede™ Billet Oil Filter & Regulator Mount

Stampede™ Oil Filter/Regulator Mounts are CNC machined from billet aluminum. Fits '84-'99 Softail®/BT and customs. Available in chrome or polished.

PART	DESCRIPTION	MSRP
STOFC	Oil Filter Bracket, Chrome	\$85.00
STOFF	Oil Filter Bracket, Polished	\$72.00



E. Feuling™ Oil Filter Cooler Kits

- This microfilter drastically reduces contamination and viscosity breakdown
- Protects from cylinder, piston, ring and bearing wear, cylinder bore polishing and high oil temps, therefore promoting engine performance, longer engine life and extended oil change intervals
- Includes housing, bracket, filter mount, braided steel lines, swivel fittings, K&N® filter and all necessary hardware.

PART	DESCRIPTION	MSRP
For '99-Later Softail®		
FE2000	Chrome w/ Stainless Lines	\$499.00
FE2005	Black Chrome w/ Black Lines	\$499.00
For '06-Later Dyna™		
FE2001	Chrome w/ Stainless Lines	\$499.00
FE2006	Black Chrome w/ Black Lines	\$499.00
For '99-Later FLT Models		
FE2002	Chrome w/ Stainless Lines	\$499.00
FE2007	Black Chrome w/ Black Lines	\$499.00
Replacement Cooler & Filter		
FE2020	Oil Filter Cooler Housing, Includes O-Rings	\$19.95



F. Stampede™ Premium Oil Filters

- Billet aluminum with flute accents for increased surface area and cooling
- Get a near match to many leading aftermarket air cleaners
- Cools oil by up to 20°F and filters down to 4 microns
- Fits BT & TC models with 3/4" x 16" thread spin-on filter mount

PART	DESCRIPTION	MSRP
STPFSP	Slant, Lacquered Polish	\$154.99
STPFSC	Slant, Chrome	\$179.99
STPFSS	Slant, Gloss Black Ano	\$179.99
STPFP	Straight Lacquered Polish	\$169.99
STPFC	Straight Chrome	\$179.99
STPFB	Straight Gloss Black Ano	\$179.99
STPFCR	High-Efficiency Replacement Cone Filter Cartridge	\$7.99

A. Oil Scavenger Total Oil Change System

- **ONLY** way to easily and effectively change all of the oil in many of today's American V-Twin motorcycle engines
- As much as 24 oz. of dirty oil remains with normal oil changes, then mixes with the clean when the engine is restarted, shortening the life of the oil and engine
- Drain oil, remove filter, install Scavenger, BRIEFLY start engine to drain oil, then install oil filter and top off the oil

PART	DESCRIPTION	MSRP
RC130	Scavenger For Sportster®	\$139.95
RC101	Scavenger For Evolution®	\$59.95
RC110	Scavenger For TC88®, '99-05 Dyna® & '99-'06 Touring	\$149.95
RC120	Scavenger For TC88B®, '00-Later	\$69.95
RC150	Dealer Start-Up Kit, Call For Details	\$408.21

A.

Scavenger™

The TOTAL Oil Change System

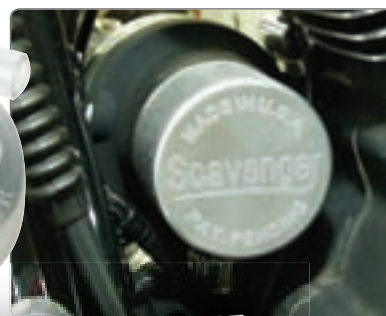

REMOVE ALL OLD OIL



FOR SPORTSTER®



FOR EVOLUTION®



FOR TWIN CAMS

RC150 Dealer Start-Up Kit



C. S&S® Oil Filters For V-Twin

- Bypass oil does not pass over dirty filter media
- Smaller diameter for easier installation

PART	DESCRIPTION	MSRP
SS314102	'84-'99, Chrome	\$12.95
SS314101	'84-'99, Black	\$10.45
SS314104	'99-Later, Chrome, Incl. Anti-Drain Back Valve	\$12.95
SS314103	'99-Later, Black, Incl. Anti-Drain Back Valve	\$10.45

C.



D.



D. K&N® Oil Filters For V-Twin

- Synthetic filter media provides outstanding filtration at high flow rates
- 17mm hex nut allows easy-on, easy wrench-off — built to racing specifications

PART	DESCRIPTION	MSRP
KN170	Performance Oil Filter For '84-'99 BT, Black	\$13.60
KN170C	Performance Oil Filter For '84-'99 BT, Chrome	\$14.65
KN171B	Performance Oil Filter For '99-Later TC, Black	\$13.39
KN171C	Performance Oil Filter For '99-Later TC, Chrome	\$14.44
KN174C	Performance Oil Filter For '02-08, V-Rod®, Chrome	\$14.44
KN173C	Performance Oil Filter For '91-'05 Dyna®, Chrome	\$15.49

E.



E. Pure Power! Lifetime High Performance Oil Filter Cooler

- CLEANABLE, REUSABLE direct spin-on replacement for the O.E.M. Oil Filter
- 90% improvement in particle removal over paper "throw away" filters
- Provides for longer engine life, extended oil change intervals, cooler operating temperatures, increased power, improved fuel mileage and lower emissions
- The last oil filter you'll ever need!

PART	DESCRIPTION	MSRP
PW8110BF	High Performance Oil Filter Cooler, '84-Later BT/TC	\$199.95

G. Pure Power! Heavy Duty SAE 15W/40 V-Twin Oil

- Specifically formulated to provide excellent performance in all recommended motorcycles
- Extremely high TBN/Alkaline Reserve (13+) that effectively neutralizes corrosive acids to protect bearings and other vital surfaces
- With Pure Power!, oil change intervals can be lengthened 2-4 times longer
- Lowers operating temps, lowers emissions, increases fuel mileage and increases horsepower
- Fortified with oxidation-corrosion inhibitors, high temperature anti-wear additives and foam inhibitors to prevent engine scuffing and bearing corrosion
- Highly effective detergent-dispersant to keep sulfated ash to a minimum

PART	DESCRIPTION	MSRP
PW10632	Heavy Duty SAE 15W/40 Oil, 12-Pack	\$107.40



F.



G. Yankee No Mess Oil Change Trough

- For '92-'99 Big Twins

PART	DESCRIPTION	MSRP
YEPT01	Pig Trough, "No Mess" Oil Change	\$14.18



A.



B.

**PERFORMANCE
 PROTECTION
 QUALITY**

A. Manhattan Oil V-Twin Superior Oil Treatment

- Extends engine and oil life • Lowers temperatures • Provides anti-friction barrier
- Quiets engine noise • Prevents viscosity breakdown • Improves shear stability
- For use with all oils • Reduces oil consumption • Increases oil pressure
- Eliminates dry starts • Prevents rust corrosion, varnish and sludge
- Improves fuel mileage • Complies with all manufacturer warranty requirements
- Will bring automotive and truck oils up to motorcycle standards

PART	DESCRIPTION	MSRP
LHT	V-Twin Superior Oil Treatment, 16 oz Bottle	\$11.95
LHTC	Oil Treatment, Case of 10 16 oz. Bottles	\$119.50

B. Liquid Horsepower Octane Booster

- Increases octane effect up to 10 points while improving combustion in all grades of gasoline
- Stabilizes fuel for storage
- Lubricates valves and upper cylinder to help prevent rust, corrosion and wear
- Increases power and fuel mileage — combustion enhancer
- Helps engines run smoother and start easier
- Can be used with all carbureted or FI engines
- Keeps fuel systems clean

PART	DESCRIPTION	MSRP
LHB3012	6 oz, Treats 30 Gal., 12-Pack	\$119.40
LHB30S	6 oz, Treats 30 Gal., Single	\$9.95
LHB524	1 oz., Treats 5 Gal., 24-Pack	\$72.00
LHB5S	1 oz., Treats 5 Gal., Single	\$3.00

C. Fuel Fragrances

- Sweeten up your exhaust with fuel fragrances!
- For gas, methanol or diesel in lawn mowers all the way to dragsters
- Sets you apart from the rest of the crowd
- Does not inhibit performance — safe for all engines
- Not effective in catalytic converter systems

PART	DESCRIPTION	MSRP
LHFCB	Cherry Bomb, 4 oz. Treats 10-20 Gal./Gas	\$9.95
LHF GG	Groovy Grape, 4 oz. Treats 10-20 Gal./Gas	\$9.95
LHFV	Victory Vanilla, 4 oz. Treats 10-20 Gal./Gas	\$9.95
LHFRB	Rippin' Root Beer, 4 oz. Treats 10-20 Gal./Gas	\$9.95
LHFBB	Burnout Blueberry, 4 oz. Treats 10-20 Gal./Gas	\$9.95



D.



K&N® Filter Maintenance Products

PART	DESCRIPTION	MSRP
KN990504	Air Filter Oil, 6.5 oz., Aerosol	\$7.94
KN990516	Air Filter Oil, 12.25 oz., Aerosol	\$9.04
KN990704	Sealing Grease, 6 oz.	\$11.49
KN990621	Recharger Treatment, 32 oz.	\$12.68

D. K&N® Air Filter Elements

- Designed to increase horsepower and torque
- Accordion design provides increased air-flow and optimum filtration
- Application specific sealing bead ensures and air tight fit

For Twin Cam:		MSRP
KN1499	For '99-'07 Models w/ Stock Twin Cam Air Cleaner	\$79.37
KN3909	For '99-'07 Road King® w/ Custom Air Cleaner	\$168.00
KN8899	For '99-'01 Fuel Injected Twin Cam Models	\$82.69
For Evolution®:		
KN1390	For '90-'99 Carbureted Softail® & Dyna® w/ Evolution®	\$65.45
KN1395	For '95-'98 Fuel Injected Models w/ Evolution®	\$73.36
KN2086	For '86-'89 FXR, FLT, FXST w/ Round Cleaner	\$49.16
KN2084	For All FX Models w/ Round Air Cleaner	\$48.45
For Stock Shovelhead:		
KN2078	For '79-'83 Shovelhead Models	\$51.46
KN0200	For '67-E75 FL '71-E'74 FX , '66-E'73 '83-'85 w/ Oval XL	\$46.96
For Models w/ Screamin' Eagle®:		
KN0800	For '99-Later TC w/ Screamin' Eagle®	\$53.50
KN0600	For '89-L'98 H-D® 1340cc H-D® w/ Screamin' Eagle®	\$46.96
KN0900	For '04-'07 XL w/ Screamin' Eagle®	\$54.00
For S&S®:		
KN3226	For S&S® E/G Teardrop	\$42.54
KN3224	For S&S® B/D Teardrop	\$40.52
For Sportster® & Buell®:		
KN1297	For '97-'98 Buell®	\$56.26
KN1388	For '88-'03 XL Models	\$70.88
KN8834	For '04-'07 XL Models	\$68.20
For V-Rod®:		
KN1102	For '02-'08 VRSCA	\$66.10
For Victory®:		
KNPL1500	For '00-'07 V92SC Kingpin & Vegas	\$57.33
KNPL1598	For '98-'99 V92SC Models	\$64.50

ENGINE
 FUEL SYSTEMS
 EXHAUST
 ELECTRICAL
 DRIVETRAIN
 WHEELS
 SUSPENSION
 SHEETMETAL
 FRAMES
 CONTROLS
 LIGHTING
 BAGGERS
 TOOLS
 APPAREL



Russell® Fuel Crossovers

- Replace stock factory hoses.
- Eliminates the use of clamps.
- Compression fit ensures a positive seal.



Russell® Pro System I Bike Builders Kit

- Assortment of all the necessary components needed by the professional bike builder for building brake lines.
- Included in kit is 25' of clear coated stainless steel braided hose, chrome banjos, bolts and adapter fittings compartmentalized in a durable plastic case.
- The insert includes photos and listings of all parts

R87006 Russell® Bike Builder Kit \$730.95

Russell® Pro System II Bike Builders Kit

R87007 Russell® Bike Builder Kit, Fits H-D® \$730.95



A. Russell® Street Use Fuel Filters

- Billet aluminum, impervious to heat and shock — 40 micron replaceable bronze filter

PART	DESCRIPTION	MSRP
R45000	1/4", Chrome	\$12.95
R45030	1/4", Black	\$12.95
R45060	5/16", Chrome	\$12.95
R45090	5/16", Black	\$12.95
R51660	Replacement Element	\$3.95



Golan Fuel Filters

- High performance, superior flow filters w/ 4" of filter area
- Designed for extreme filtration environments

PART	DESCRIPTION	MSRP
GN60312C	Mini Filter For .25", .312", .375"; 4-AN Or 6-AN	\$46.65
GN70312G	Super Mini Filter For .25" Or .312"	\$43.80

Line Fitment For:	Front Brake Line	Rear Brake Line	Pro System Oil Line Kit	Fuel Crossover Line
'86-'87 FLST (Prior To 2/1/87)	R08745DS	R08814S	('87) R50000	R54300-R54320
'87-'91 FLST/FLSTC (After 2/1/87)	R08745DS	R08839DS	('87-'89) R50000 ('90-'91) R50001	R54300-R54320
'92-'99 FLST/FLSTC	R08745DS	R08839DS	(E '92) R50001 (L '92-'99) R50002	R54300-R54320
'00-'03 FLSTC Heritage Classic®	R08745DS	R08838DS	('00-'01) R50020	R54321
'90-'99 FLSTF/FLNV	R08745DS	R08839DS	('90-E '92) R50001 (L '92-'99) R50003	R54300-R54320
'00-'03 FLSTF Fat Boy®	R08745DS	R08838DS	('00-'01) R50020	R54321
'97-'99 FLSTS Springer®	R08757DS	R08839DS	R50002	R5430-R54320
'00-'03 FLSTS	R08757DS	R08838DS	R50020	('00-'01) R54321
'84-'86 FXST/FXSTC Custom	R08728DS	R08814S	N/A	('86) R54300-R54320
'87 FXST/FXSTC (Prior To 2/1/87)	R08728DS	R08814S	R50000	R54300-R54320
'87 FXST/FXSTC (After 2/1/87)	R08728DS	R08837DS	R50000	R54300-R54320
'88-'91 FXST/FXSTC Custom	R08837DS	R08837DS	('88-'89) R50000 ('90-'91) R50001	R54300-R54320
'92-'98 FXST/FXSTC Custom	R08728DS	R08837DS	(E '92) R50001 (L '92-'98) R50002	R54300-R54320
'99 FXST	R08771DS	R08837DS	R50002	R54300-R54320
'00-'03 FXST	R08771DS	R08838DS	R50020	('00-'01) R54321
'00-'01 FXSTC Custom	R08728DS	R08838DS	R50020	R54321
'88-'91 FXSTS Springer®	R08947DS	R08837DS	('88-'89) R50000 ('90-'91) R50001	R54300-R54320
'92-'95 FXSTS Springer®	R08947DS	R08837DS	(E '92) R50001 (L '92-'95) R50002	R54300-54320
'96-'99 FXSTS Springer®	R08760DS	R08837DS	R50002	R54300-R54320
'00-'03 FXSTS Springer®	R08760DS	R08838DS	R50020	('00-'01) R54321
'95-'97 FXSTSB Bad Boy®	R08761DS	R08837DS	R50002	R54300-R54320
'99 FXSTB Night Train®	R08770DS	R08837DS	R50002	R54300-R54320
'00-'03 FXSTB Night Train®	R08770DS	R08838DS	R50020	('00-'01) R54321
'00-'03 FX Standard Deuce®	R08774DS	R08838DS	R50020	N/A
'87 FXRT/FXRD (Prior To 2/1/87)			R50003	
'87 FXRT/FXRD (After 2/1/87)			R50003	
'88-'91 FXRS Sport ('87-'90)			R50003 ('91) R50004	
'92-'93 FXRS Sport			R50004	
'87-'90 FXLR			R50003	
'91 FXLR			R50004	
'92-'94 FXLR			R50004	
'88-'91 FXRT Sport Glide®			('88-'90) R50003 ('91) R50004	
'92 FXRT Sport Glide®			R50004	
'88-'91 FXR/FXRS/FXRC			('88-'90) R50003 ('91) R50004	
'92-'94 FXR/FXRS/FXRC			R50004	
'89-'91 FXRS Convertible			('89-'90) R50003 ('91) R50004	
'92-'93 FXRS Convertible			R50004	

GIVE US A CALL FOR RUSSELL® LATE MODEL FITMENTS!

B.



B. Russell® Pro System II Nylon Brake Lines

- Ideal for the custom builder to fabricate lines w/ maximum flexibility
- Non-abrasive, small diameter lines won't hurt a custom paint job
- Available in blue, red, yellow and black to accent your paint scheme
- Rated at 1200 PSI. Does not meet DOT specs

See MCAAdvantages.com For Complete List

C.



C. Criminal Customs Tube-Mount Brake Tee

- T6-6061 aluminum low profile tee makes clean brake switch mounting a snap
- Kit includes hardware, drill bit and tap

PART	DESCRIPTION	MSRP
CRBT1K	1" Mount, Drill Bit & Tap Incl.	\$55.00
CRBT1	1" Mount, Parts Only	\$50.00
CRBT118K	1.125" Mount, Drill Bit & Tap Incl.	\$55.00
CRBT118	1.125" Mount, Parts Only	\$50.00
CRBT114K	1.25" Mount, Drill Bit & Tap Incl.	\$55.00
CRBT114	1.25" Mount, Parts Only	\$50.00



A.

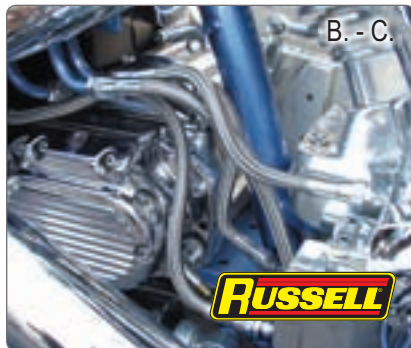

B. - C.



D.

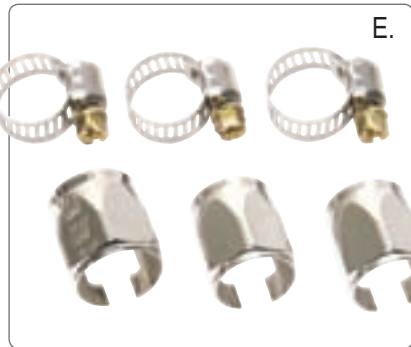

E.



F.



G.



H.



I.

A. Russell® Brake Lines (Front & Rear)

- Rugged 308 stainless steel braided hose
 - Teflon® inner liner eliminates brake line expansion for more braking power
 - Will not deteriorate from brake fluid, clear coated—won't scratch painted surface
- See MCAdvantages.com For Complete List Of Products

B. Russell® Pro System Oil Line Kits

- Replaces stock hoses, eliminates clamps, compression fit ensures positive seal
- See MCAdvantages.com For Complete List Of Products

C. Russell® Universal Pro System Oil Lines

- Pre-assembled, constructed with stainless braided hose and on chrome ends
- Compression fit sealing ensures a positive seal
- Compatible with standard 3/8" oil pump and oil tank fittings. **MSRP:**

R50100 8"	\$39.95	R50105 13"	\$41.95	R50110 18"	\$43.95
R50101 9"	\$40.95	R50106 14"	\$42.95	R50111 20"	\$44.95
R50102 10"	\$40.95	R50107 15"	\$42.95	R50112 22"	\$44.95
R50103 11"	\$41.95	R50108 16"	\$42.95	R50113 24"	\$45.95
R50104 12"	\$41.95	R50109 17"	\$43.95	R50114 26"	\$46.95

D. Russell® Stainless Steel Streetflex Hose With Rubber Core

- Single wire stainless outer braid and a CPE inner liner
- Operating pressure of 250 PSI.
- Use with Tube Seal Hose Ends for a professional looking installation **MSRP:**

R33020 6' x 4.5 1/4" ID	\$25.95	R33120 25' 6 5/16" ID	\$32.95
R33050 25' x 4.5 1/4" ID	\$108.95	R33160 6' x 7 3/8" ID	\$35.95
R33090 6' x 6 5/16" ID	\$32.95	R33190 25' x 7 3/8" ID	\$188.95

E. Russell® Tube Seal Chrome Hose Ends

- Gives a finished look to your steel braided hoses w/ chrome-plated durability
- Manufactured from aircraft quality aluminum **MSRP:**

R49970 -4.5 x 1/4" ID (6)	\$20.95	R49976 -7 x 3/8" ID (6)	\$19.95
R49971 -6 x 5/16" ID (6)	\$21.95		

F. Spyke® Universal Swiveling Petcock

- 360° swivel outlet that allows for universal positioning so one part number fits most OEM applications, including all H-D® applications
- Unique clicking detents to identify all three valve positions
- Significantly outflows any performance modification
- Made from triple chrome plated brass for a show finish

PART	DESCRIPTION	MSRP
SPPC	Petcock For '75-Later (Except Fuel Injection)	\$79.99
SPPC38	Petcock 3/8" NPT Pre-'75 BT (Except Fuel Injection)	\$79.99
SPPCRK	Petcock Seal Replacement Kit	\$49.99

G. Golan Click Slick Ball Bearing Petcocks

- High performance, second generation, NEW TECHNOLOGY petcock
- Made from show chromed 360 brass, stainless steel ball-bearings and components
- Prevents a frozen valve, providing a secure seal in the "OFF" position — O-Ring seat secures any leaks from the petcock fuel valve to the carburetor

PART	DESCRIPTION	MSRP
GN75516B	3/8" NPT Ball Bearing Petcock, Backward 5/16" Fitting	\$108.00
GN75516D	3/8" NPT Ball Bearing Petcock, Downward 5/16" Fitting	\$108.00
GN75516F	3/8" NPT Ball Bearing Petcock, Forward 5/16" Fitting	\$108.00
GN75516S	3/8" NPT Ball Bearing Petcock, Straight 5/16" Fitting	\$108.00
GN755166	3/8" NPT Ball Bearing Petcock, 6-AN Fitting	\$115.00
GN76312B	22mm Ball Bearing Petcock, Backward 5/16" Fitting	\$108.00
GN76312D	22mm Ball Bearing Petcock, Downward 5/16" Fitting	\$108.00
GN76312F	22mm Ball Bearing Petcock, Forward 5/16" Fitting	\$108.00
GN76312S	22mm Ball Bearing Petcock, Straight 5/16" Fitting	\$108.00
GN763126	22mm Ball Bearing Petcock, 6-AN Fitting	\$115.00

I. S&S® Fuel Pump For Fuel Injected Custom Bikes

- Can be mounted in nearly any tank
- Hollow mounting bolts also provide an outlet for wiring and pressurized fuel
- Fiber media filter prevents contaminants from damaging the pump or injectors

PART	DESCRIPTION	MSRP
55-5089	S&S® Fuel Pump Kit	\$549.95

ENGINE
 FUEL SYSTEMS
 EXHAUST
 ELECTRICAL
 DRIVETRAIN
 WHEELS
 SUSPENSION
 SHEETMETAL
 FRAMES
 CONTROLS
 LIGHTING
 BAGGERS
 TOOLS
 APPAREL

A. Cometic Head & Base Gaskets

- **Multi-Layer Steel** gaskets are ideal for any head and cylinder materials
- Comprised of two embossed viton coated stainless steel outer layers and a variable stainless center layer
- No re-torque is required after initial torque set

PART	DESCRIPTION	MSRP
Head Gaskets, MLS For:		
CG9790	'99-Later TC, 3.750" Stock Bore, .030" Spring Steel, 2-Pack	\$41.24
CG9745	'99-Later, 3.750" Stock Bore, .040" Spring Steel, 2-Pack	\$45.66
CG9721	'99-Later, 1550 Big Bore Kit, .030" Spring Steel, 2-Pack	\$41.24
CG9132	'99-Later, 1550 Big Bore Kit, .045" Spring Steel, 2-Pack	\$41.24
CG9931	'99-Later, S&S® SSW+ 4 1/8" H/G, .030" Spring Steel, 2-Pack	\$41.24
CG9933	'99-Later, S&S® SSW+ 4 1/8" H/G, .040" Spring Steel, 2-Pack	\$41.24
CG9934	'99-Later, S&S® SSW+ 4 1/8" H/G, .045" Spring Steel, 2-Pack	\$41.24
CG9688	'84-'99 BT/1200 XL, Stock, .030" Spring Steel, 2-Pack	\$41.24
CG9689	'84-'99 BT/1200 XL, Stock, .040" Spring Steel, 2-Pack	\$41.24
CG9984	'66-'84 BT, 74" & 80", 2-Pack	\$41.24
CG9985	'66-'84 BT, 3 5/8" Big Bore, 2-Pack	\$41.24

PART	DESCRIPTION	MSRP
Base Gaskets For:		
CG9935	'99-Later TC, S&S® SSW+ 4 1/8", .010" SLS, 2-Pack	\$21.84
CG9936	'99-Later TC, S&S® SSW+ 4 1/8", .020" SLS, 2-Pack	\$21.84
CG9551	'84-'99 BT, 1340 Kit, .020" Spring Steel, 2-Pack	\$21.84
CG9553	Evolution® 883/1200 XL, .020" SLS, 2-Pack	\$21.84
CG9987	'48-'84 BT Front & Rear Viton Coated, .020" SLS, 2-Pack	\$21.84
CG9989	'48-'84 S&S® w/ 3 5/8", 2 Fronts, .020" SLS, 2-Pack	\$21.84

B. Cometic Top End Gaskets

- **EST (Extreme Sealing Technology)** kits contain MLS Head Gaskets, Steel Viton coated Base Gaskets, blue Viton Valve Stem Seals and AFM material
- Race Style Exhaust Gasket won't fray into the port
- One-piece Evolution® rocker box base gasket is made from a single layer of .020" thick embossed Viton coated steel

PART	DESCRIPTION	MSRP
Top End EST Gasket Kits For:		
CG9635	'92-'99 Evolution®	\$97.24
CG9766	'92-'99 Evolution® BT w/ 3 5/8" Bore	\$97.24
CG9780	'99-'02 TC w/ 1550 Big Bore, .040" Head Gasket	\$124.33
CG9779	'99-Later TC w/ Stock Bore, .040" Head Gasket, High Perf.	\$126.10
CG9146	'03-Later TC w/ Stock Bore & Hat-Style Valve Stem Seal	\$102.08
CG9147	'03-Later TC w/ 1550cc Big Bore & Hat-Style Valve Stem Seal	\$102.08
CG9052	'77-'85 Hi-Comp 1000 XLH/CH/S, Repl. OEM #17030-72B	\$50.08
CG9763	'91-'03 1200 Evolution® 1200 XL, Kit	\$97.24
CG9970	'04-Later Evolution® 1200 XL	\$97.24
CG9177	'07-Later 1200 XL	\$156.99
CG9918	'66-'84 Shovel w/ 3 5/8" Big Bore	\$91.68
CG9967	'66-'84 4/5-Speed 74"/80" Shovel, Repl. OEM #17034-66X	\$91.68
CG9865	Rocker Cover Gaskets, 1-Piece Base, '84-'99 Evolution®, 2-Pk	\$14.09
CG9752	Rocker Box Rebuild Gasket Kit, '92-'99 Evolution®	\$43.73

C. Cometic Bottom End & Powertrain Gaskets

- Chemically blown compounded nitrile rubber bonded to an aluminum core
- Temperature resistance of over 250° F (121° C) and an 85% recovery while maintaining a strong torque retention, installs dry

PART	DESCRIPTION	MSRP
CG9173	Complete Primary Gasket & Seal Kit '07-Later FL	\$83.46
CG9305F5	Inspection Cover Gaskets, '85-Later FL/FXR, 5-Pack	\$29.48
CG9338F5	Derby Cover Gasket, '70-'83 FL/FXR, 5-Pack	\$34.74
CG9152F5	Derby Cover Gasket, '06-Later, Replaces OEM #17369-06, 5 Pack	\$24.54
CG9997F5	Derby Cover Gasket, '99-Later TC, Replaces OEM #25416-99C, 5 Pk	\$24.54
CG9145F5	Primary Cover Gasket, '06-Later Dyna™, 5-Pack	\$138.94
CG9309F5	Primary Cover Gasket, '89-'06 Softail® & '89-'05 Dyna™, 5-Pack	\$138.94
CG9309F1	Primary Cover Gasket, '89-Later Softail® & '89-'05 Dyna™, Single	\$30.89
CG9307F5	Primary Cover Gasket, '94-Later FLT/FXR w/ 1340cc Evolution®, 5-Pk	\$138.94
CG9314F5	Primary Cover Gasket, '91-'03 Sportster®, 5-Pack	\$96.30
CG9943F5	Primary Cover Gasket, '04-Later Sportster®, 5-Pack	\$96.30
CG9151	Transmission Gasket Kit, '06-Later Dyna™	\$50.08
CG9174	Transmission Gasket Kit, '07-Later Softail®	\$68.90
CG9175	Transmission Gasket Kit, '07-Later FL	\$68.90
CG9328F5	Cam Cover Gasket, AFM '93-'98 BT, 5-Pack	\$30.68
CG9575F5	Cam Cover Gasket, AFM '99-'07 TC, 5-Pack	\$49.97
CG9313F5	Cam Cover Gasket, AFM '91-'03 XL, 5-Pack	\$55.54
CG9944F5	Cam Cover Gasket, 04-Later XL, 5-Pack	\$29.48

COMETIC® GASKET

Cometic Gaskets

Cometic has quickly become the leader in custom gaskets for H-D®. Their advanced engineering and manufacturing process allows them to manufacture gaskets with the most precise fit and extreme durability. Call MC Advantages for any Cometic Gasket product.

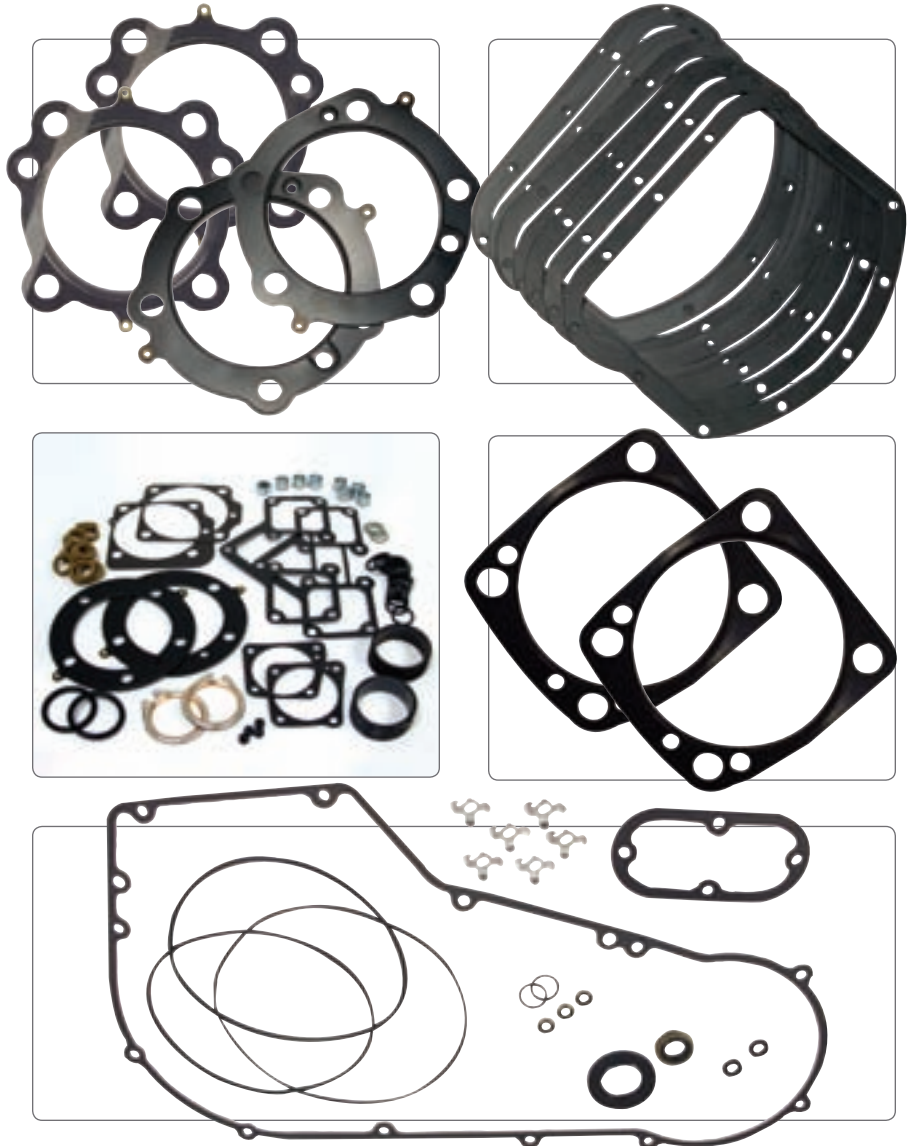

D. Cometic EST Complete Engine Gasket Kits For:

PART	DESCRIPTION	MSRP
CG9964	'66-'84 70"/84" 4-Speed Shovel	\$130.16
CG9748F	'92-'99 Evolution® BT	\$244.76
CG9148	'06-Later Dyna® w/ Stock Bore	\$143.99
CG9149	'06-Later Dyna® w/ 1550 Big Bore	\$143.99
CG9777F	'99-'06 TC Softail®/Dyna®	\$197.70
CG9171	'07-Later Softail® w/ Stock Bore	\$197.90
CG9778F	'99-'06 FLT	\$194.43
CG9172	'07-Later FL w/ Stock Bore Incl. Primary Gaskets	\$197.90
CG9051F	'77-'85 1000 XLH/CH/S Hi-Comp.	\$120.95
CG9176	'07-Later 1200 XL	\$198.59

E. Cometic Intake & Exhaust Gaskets

Exhaust gaskets are made out of various materials, as required by model, such as armor clad, copper, graphite or spiral wound steel.

Exhaust Gaskets

CG9288	Tapered, '99-Later, 10-Pk	\$43.78
CG9719	Race Style, All '99-Later Models, 10-Pk	\$37.02

Manifold Gaskets

CG9290	Intake Manifold Gasket To Head Seal	\$18.20
--------	-------------------------------------	---------



S&S® Complete Engine Rebuild Gasket Kits

PART	DESCRIPTION	MSRP
SS1060976	T-Series, '99-'06, 4.125"	\$99.95
SS1060964	V-Series, '84-'99, 4.125"	\$94.95
SS1061020	V-Series, '84-'99, 4"	\$94.95
SS1060992	V-Series, '84-'99, 3.75"	\$94.95
SS1060407	SH-Series, '66-'84, 3.5"	\$94.95
SS1060408	P-Series/SH-Series, '48-'84, 3.625"	\$99.95



S&S® Base Gaskets & O-Rings

PART	DESCRIPTION	MSRP
For '99-'06 T-Series Engines:		
SS931082	4.375", .018" Micropore, 2-Pack	\$7.45
SS931074	4.125", .018" Micropore, 10-Pack	\$42.45
SS931921	4.125** .018" Micropore, 10-Pack	\$30.95
SS931068	4", .018" Micropore, 10-Pack	\$29.95
SS508104	4", .103" Viton O-ring 10-Pack	\$42.45
SS508103	3.875", .103" Viton O-ring 10-Pack	\$40.45
SS508103	3.75", .103" Viton O-ring 10-Pack	\$40.455
For '84-'99 V-Series Engines		
SS931082	4.375", .018" Micropore, 2-Pack	\$7.45
SS931074	4.125", .018" Micropore, 10-Pack	\$42.45
SS931067	4", .018" Micropore, 10-Pack	\$34.95
SS931064	3.625", .018" Micropore, 10-Pack	\$29.95
SS931063	3.5", .018" Micropore, 10-Pack	\$32.95
For '66-'84 SH-Series Engines:		
SS931064	3.625", .018" Micropore, 10-Pack	\$29.95
SS931063	3.5", .018" Micropore, 10-Pack	\$32.95
For '48-'65 P-Series Engines:		
SS931064	3.625", .018" Micropore, 10-Pack	\$29.95
For SB-Series Engines:		
SS931067	4", .018" Micropore, 10-Pack	\$34.95
SS931066	3.625", .018" Micropore, 10-Pack	\$29.95
SS931065	3.5", .018" Micropore, 10-Pack	\$32.95



S&S® Rocker Cover Gasket Kits

For '99-Later Twin Cam Models		
SS904073	Up to 4" Bore, Billet	\$33.95
SS904111	Up to 4" Bore, Die Cast	\$46.45
SS904097*	Up to 4" Bore, Billet	\$40.95
SS904111	4.125", Die Cast	\$46.45
For '66-'99 BT Models		
SS904311	'66-'84 Big Twin, Billet	\$33.95
SS904049	'84-'91 Big Twin, Billet	\$45.95
SS904091	'84-'91 Big Twin, Die Cast	\$49.95
SS904046	'84-'91 Big Twin, Stock H-D®	\$39.45
SS904049	'92-'99 Big Twin, Billet	\$45.95
SS904091	'92-'99 Big Twin, Die Cast	\$49.95
SS904047	'92-'99 Big Twin, Stock H-D®	\$40.45
SS904111	'66-'99 4.125" Bore Big Twin	\$46.45
For Sportster®:		
SS904049	'86-'90 XL, Billet	\$45.95
SS904091	'86-'90 XL, Die Cast	\$49.95
SS904049	'91-'03 XL, Billet	\$45.95
SS904091	'91-'03 XL, Die Cast	\$49.95



S&S® Cylinder Head Rebuild Gasket Kits

PART	DESCRIPTION	MSRP
SS901915	T-Series, '99-'06, 4.125"	\$37.95
SS901914	T-Series, '99-'06, 4.125", Stock Cases	\$74.95
SS901913	T-Series, '99-'06, 4"	\$36.95
SS901912	T-Series, '99-'06, 3.875"	\$36.95
SS901911	T-Series, '99-'06, 3.75"	\$36.95
SS901910	V-Series, '84-'99, 4.125"	\$37.95
SS901909	V-Series, '84-'99, 4"	\$26.95
SS901906	V-Series, '84-'99, 3.625"	\$26.95
SS901905	V-Series, '84-'99, 3.5"	\$26.95
SS901918	SH-Series, '66-'84, 3.625"	\$27.95
SS901917	SH-Series, '66-'84, 3.5"	\$27.95
SS901918	P-Series, '48-'65, 3.625"	\$27.95
SS901909	SB-Series, '86-'03, 4"	\$26.95
SS901908	SB-Series, '86-'03, 3.625"	\$26.95
SS901907	SB-Series, '86-'03, 3.5"	\$26.95



S&S® Micropore Head Gaskets & O-Rings

PART	DESCRIPTION	MSRP
For '99-'06 T-Series Engines:		
SS931081	4.375", .045", 2-Pack	\$20.45
SS931073	4.125", .043", 10-Pack	\$84.45
SS931080	4.125", .045", 10-Pack	\$78.95
SS931920	4.125** .043", 10-Pack	\$231.45
SS931058	4", .043", 10-Pack	\$82.95
SS931059	3.875", .043", 10-Pack	\$99.95
SS931060	3.75", .043", 10-Pack	\$99.95
For '84-'99 V-Series Engines		
SS931073	4.125", .043", 10-Pack	\$85.45
SS931071	4", .045", 10-Pack	\$55.95
SS931052	3.625", .045", 10-Pack	\$59.95
SS931053	3.625", .0625", 10-Pack	\$74.95
SS931024	3.5", .045", 10-Pack	\$57.95
SS931051	3.5", .0625", 10-Pack	\$69.95
For '66-'84 SH-Series Engines:		
SS931062	3.625", .032", 10-Pack	\$81.45
SS931061	3.5", .032", 10-Pack	\$81.45
For '48-'65 P-Series Engines:		
SS931062	3.625", .032", 10-Pack	\$81.45
SS931054	3.625", .032", Composite, 10-Pack	\$87.95
For SB-Series Engines:		
SS931071	4", .045", 10-Pack	\$55.95
SS931052	3.625", .045", 10-Pack	\$59.95
SS931053	3.625", .0625", 10-Pack	\$74.95
SS931024	3.5", .045", 10-Pack	\$57.95
SS931051	3.5", .0625", 10-Pack	\$69.95



S&S® Gear Cover Gaskets

PART	DESCRIPTION	MSRP
SS312063	'99-Later BT (OE#25244-99), 10-Pack	\$51.95
SS1060232	'70-'99 BT (OE#25225-70B, 93), 10-Pk	\$22.95
SS312060	'36-'69 BT (H-D#25225-36C), 10-Pack	\$41.95
SS312099	'86-Later S&S®, 5-Pack	\$15.45
SS312098	'86-Later S&S® w/o Filter Boss, 5-Pack	\$30.95



S&S® Top End Rebuild Gasket Kits

PART	DESCRIPTION	MSRP
SS909511	T-Series, '99-'06, 4.375"	\$59.45
SS909506	T-Series, '99-'06, 4.125"	\$71.95
SS909510	T-Series, '99-'06, 4.125", Stock Cases	\$71.95
SS909505	T-Series, '99-'06, 4"	\$61.95
SS909504	T-Series, '99-'06, 3.875"	\$56.45
SS909511	V-Series, '84-'99, 4.375"	\$59.45
SS909506	V-Series, '84-'99, 4.125"	\$71.95
SS909503	V-Series, '84-'99, 4"	\$55.45
SS909502	V-Series, '84-'99, 3.625"	\$54.45
SS909507	V-Series, '84-'99, 3.5"	\$59.45
SS909501	SH-Series, '66-'84, 3.625"	\$82.45
SS909500	SH-Series, '66-'84, 3.5"	\$82.45
SS909503	SB-Series, '86-'03, 4"	\$55.45
SS909503	SB-Series, '86-'03, 3.625"	\$55.45
SS909503	SB-Series, '86-'03, 3.5"	\$55.45



S&S® Carb Gaskets

PART	DESCRIPTION	MSRP
Bowl Gaskets for S&S® Carburetors		
SS112387	Bowl Gasket, Super E & G, 10-Pack	\$20.95
SS112091	Bowl Gasket, Super B & D, 10-Pack	\$17.95
SS112290	Bowl Gasket, Two-Throat, 5-Pack	\$7.45
SS112061	Bowl Gasket, "L" Series, 5-Pack	\$8.45
SS112080	Bowl Gasket, Super B Fuel, Turbo	\$1.95
SS112153	Bowl Gasket, Super D Fuel, Turbo	\$2.95
Carburetor To Manifold, O-Ring or Gasket		
SS508094	O-Ring, Super E, 10-Pack	\$7.95
SS508093	O-Ring, Super G, 10-Pack	\$7.45
SS508101	O-Ring, Super B, 10-Pack	\$4.45
SS501042	O-Ring, Super D, 10-Pack	\$22.45
SS508101	O-Ring, "L" Series, 1.75"/1.875", 10-Pk	\$4.45
SS160257	Gasket, Two-Throat, 5-Pack	\$5.95
Gaskets for S&S® Air Cleaners		
SS170197	Super B, 5-Pack	\$7.45
SS170383	Super E & G, 10-Pack	\$7.45
Miscellaneous Carburetor Seals and Gaskets		
SS112279	Bellows Seal, Accelerator Pump, 5-Pk	14.95
SS508095	O-Ring, Seat and Bowl Plug, 10-Pack	\$9.95
SS508096	O-Ring, Ejector Nozzle, 10-Pack	\$6.95
SS508100	O-Ring, Pump Cap, 10-Pack	\$8.45
SS112253	Accelerator Pump Gasket, 2-Throat, 5-Pk	\$3.95
Manifold To Head Seals For:		
O-Ring – S&S® Manifolds		
SS160243	Evolution® & TC88®, 10-Pack	\$37.95
O-Ring – Stock Manifolds		
SS160244	Evolution® & TC88®, 10-Pack	\$34.95
SS508132	'55-'78 BT & '57-'78 XL, 10-Pack	\$31.95
Rubberband		
SS160245	'79-'84 BT & '79-'85 XL, 10-Pack	\$20.45

S&S® VFI Gaskets

PART	DESCRIPTION	MSRP
SS555021	S&S® VFI Gasket Kit: Manifold to Head Gasket (2) Throttle Body Gasket (2) Intake Air Temp Sensor Gasket (1)	\$17.45

ENGINE
FUEL SYSTEMS
EXHAUST
ELECTRICAL
DRIVETRAIN
WHEELS
SUSPENSION
FRAME
SHEETMETAL
CONTROLS
BAGGERS
LIGHTING
TOOLS
APPAREL

A. Jet Scream Plus

- Patent-pending design laminizes air as it enters the engine
- **Allows for better fuel atomization to improve engine performance**
- Simply bolt the Jet Scream Plus into the existing back plate and experience more power, more torque and better fuel mileage out of the box!
- Fits for:

PART	DESCRIPTION	MSRP
JSTC	For '99-'07 TC w/ Screamin' Eagle® High Flow Kit & Delphi® FI	\$69.00
JSK	Kuryakym® Hypercharger or Twin Velocity	\$79.00
JSM	Mikuni®	\$79.00
JSABS	Arlen Ness® Big Sucker™	\$79.00
JSHS	S&S® Carb	\$69.00
JSSST	S&S® Carb w/ Teardrop	\$89.00
JSHXL4	'04-Later XL	\$69.00
JSKN	K&N® RK-3909	\$79.00
JSHXLE	Pre-'03 XL/Evolution®	\$79.00
JSVS	Velocity Stack Or 90° Elbows w/ CV Bolt Pattern	\$69.00
JSHTCK	Backing Plate For '01-'06 FI Twin Cam 88®	\$299.99



B. S&S Cycle® Single Bore Induction Systems

In an effort to help dealers and retail customers make the right selection choices for specific applications, S&S® developed the following process to help in ordering Single Bore Induction Systems.

STEP 1: SELECT A MANIFOLD, '01-'06 BT

PART	DESCRIPTION	MSRP
SS165141	Fits 88", 95", 103" & 106", 4.937" Cyl., 410 Manifold	\$119.95
SS165134	Fits 100", 4.850" Cyl., 405 Manifold	\$119.95
SS165135	Fits 107", 4.975" Cyl., 414 Manifold	\$119.95
SS165136	Fits 111", 4.763" Cyl., 398 Manifold	\$119.95
SS165137	Fits 116", 5.160" Cyl., 428 Manifold	\$119.95
SS165138	Fits 117", 4.888" Cyl., 408 Manifold	\$119.95
SS165139	Fits 124", 5.013" Cyl., 417 Manifold	\$119.95

STEP 2: SELECT A THROTTLE BODY KIT

SS175068	Throttle Body Kit, '95-'01 BT (Except Softail®)	\$874.95
SS175067	Throttle Body Kit, '02-'05 BT (Except Softail®)	\$719.95

STEP 3: SELECT A RUNNER KIT OR AIR CLEANER

Air Cleaners:

SS170498	Teardrop For Stock H-D®/S&S® Heads or 4" Bore	\$199.95
SS170497	Desperado For Stock H-D®/S&S® Heads or 4" Bore	\$199.95
SS170496	Desperado For S&S® Heads w/ 4 1/8" Bore	\$199.95

Single-Bore Tuned Induction Runner Kits:

SS171005	Single Bore Kit, Chrome	\$324.95
SS171003	Single Bore Kit, Black Powdercoat	\$239.95
SS171001	Single Bore Kit, Natural	\$239.95
SS171046	Bracket For '84-'06 BT w/ 4 1/8" Heads	\$374.95
SS171047	Bracket For '84-'06 BT w/ Stock or S&S® Breather	\$374.95

B. Single Bore Induction Ordering Process



Step 1: Select a manifold based on the size of your engine. These manifolds are specifically designed for EFI applications. They include fuel injector mounting ports and provision for a stock-style MAP sensor. Available in most stock lengths and for fitment with S&S® Hot Set Up Kits. Custom manifolds are available by special order, please ask your MC Advantages sales representative for details.

Step 2: Select a throttle body. S&S® premium throttle body comes with body, fuel rail, fuel injectors, fuel injector wiring adapters, breather hardware and required seals. Stock air temp sensor, throttle position sensor, idle air control and MAP sensor can be reused.



Step 3: Select a runner kit or air cleaner. S&S® offers three runner kits in chrome, black powdercoat or natural finishes. S&S® offers three air cleaners to meet your EFI needs. The first two kits fit stock Harley-Davidson® cylinder heads or S&S heads for stock or 4" bore engines. The third kit is for S&S 4 1/8" bore engines like the T124 or 124" Hot Set Up Kit equipped with S&S Cylinder heads.

C. Daytona Twin Tec Twin Tuner FI Controller For '01-'07 TC

- Increased horsepower at a lower cost!
- Improved throttle response
- Easy plug-in installation and setup
- Very compact size - only 4" x 2" x 0.5"
- Can use Dynojet® Power Commander maps
- Compatible with Twin Scan II+ Tuning Aid
- Excludes '08 touring models with electronic throttle body

PART	DESCRIPTION	MSRP
DATWINTUNER	Fuel Injection Controller For '01-Later TC w/ Delphi® & '99-Later Buell® w/ DDFI Fuel Injection	\$199.00
DATWINADAPTHARN	Twin Tuner Adapter Harness	\$39.00
DATWINPWRADAPT	Twin Tuner Power Adapter	\$70.00





A.

A. Daytona Twin Tec Gen III Fuel Controller For '01-'08 TC

- Simultaneously auto-tune fuel curves for both cylinders under riding conditions
- Fully programmable plug-in replacement for Delphi® controller
- Robust alpha-N fuel control eliminates problems with long duration camshafts
- Powerful software for custom programming, analysis, logging and diagnostics
- Full support for J1850 data bus used for communications with turn signal/security module (TSM/TSSM) and instrument cluster
- Does not fit '08 touring models
- Supports all sensors including theft/security module — easy plug-in installation

PART	DESCRIPTION	MSRP
DATCFI3DKIT	TCFI III Fuel Injection Kit (Supersedes TCFI2D-KIT) Includes WEGO III & Bosch® O ₂ Sensors	\$875.00



B.

B. Daytona Twin Tec WEGO III Air/Fuel Ratio Tuning Aid

- Complete air/fuel ratio metering system with built-in data logging
- Includes WEGO III, Bosch LSU4.2 5-wire oxygen sensor, 18x1.5mm weld nut for mounting sensor on exhaust pipe, and software
- Displays air/fuel ratio and logs over 2 hours data including AFR & RPM

PART	DESCRIPTION	MSRP
DAWEGO3SYS	WEGO III Wide-band Exhaust Gas Oxygen System	\$399.50

C. S&S® EZFI™

- Provides economical tuning for stock engines with mild performance upgrades
- Add on to existing stock ECM
- Retain stock TSSM functions
- Fits all Delphi® equipped Harley-Davidson® models

PART	DESCRIPTION	MSRP
SS1060890	EZFI Module Kit	\$104.95
SS1060891	Wiring Harness (Bypass)	\$104.95
SS551271	Diagnostic Cable	\$104.95



C.

D. Dynatek® Fuel Injection Controller

- The fastest and simplest way to fine tune fuel delivery without a computer
- Measures only 2 3/4" x 1 3/4" x 3/4"
- Use a screwdriver to adjust the low, mid and high range from -20% through +20%
- Four selectable curves correspond to the level of performance modifications

Fits for:	MSRP
DCFCH1 '97-'98 Touring w/ Evolution®	\$249.00
DCFCH2 '99-'01 Touring w/ TC	\$249.00
DCFCH3 '02-'05 Touring w/ TC	\$249.00
DCFCH6 '06 Touring w/ TC	\$249.00
DCFCH8 '06 Dyna™	\$259.00
DCFCH4 '01-'05 Softail® & Dyna™	\$249.00
DCFCH7 '06 Softail®	\$249.00
DCFCH5 '02-'06 V-Rod®	\$249.00



D.

E. Techlusion Fuel Injection / Dobeck Performance - TFi

- Carburetor tuning logic for easy adjustments with powerful results
- Requires no web downloads, maintains the stock fuel map
- Load-based system verses RPM-based for better performance.

PART	DESCRIPTION	MSRP
TFI1040ST	For '95-'05 Fuel Injected Big Twins	\$245.00
TFI1240ST	For '06 Softail® & Touring Models	\$245.00
TFI1250ST	For '06-'08 Dyna®, '07-'08 Softail® & '07 Touring Models	\$255.00
TFI1252ST	For '08 Touring Models	\$254.00
TFI1251ST	For '07-'08 Sportster®	\$255.00
TFI1046ST	For '02-'07 V-Rod®	\$245.00
TFI1253ST	For '08 V-Rod®	\$254.00



E.

F. S&S® VFI Closed-Loop Sensor Kit



- Allows VFI users to upgrade to a closed loop system
- Includes two oxygen sensors, two weld-in exhaust bosses, oxygen sensor wiring subharness, connectors and instructions

SS551590	'01-'05 Delphi® Style	\$289.95
SS551620	L'95-'01 MM Style	\$279.95

The Highest-Tech Carb Is Also The Easiest To Use.

Big-Air adjustability is equivalent to 15 different main jets in the other maker's standard carbs

3 simple external fuel knobs can be adjusted in seconds. No teardown needed to tune. (Pilot Fuel At Bottom Right)

A ribbed venturi passes more air and vaporizes fuel better than the 20-year-old technology of other carbs.

Highly atomized fuel vaporization keeps fuel in suspension longer for incredible throttle response. Meets 2010 emissions standards.

8 internal ball bearing rollers ensure a very smooth slide.

The Big-Air Carb is the only carb on the market with a 3-year limited warranty.

Big-Air Carbs fit 80"-100", 103"-113", 117"-131" and 124"-155" engines with an S&S® Super G intake manifold.

The Big-Air is the first carburetor in 20 years to introduce completely new technology to the V-Twin market.

Setup for single-cable or dual-cable pull

A. PSI Big Air Carburetor

PART	DESCRIPTION	MSRP
GBA00	Big-Air Carburetor For 80"-100" Engines, Milled	\$1,099.99
GBA00B	Big-Air Carburetor For 80"-100" Engines, Black	\$1,099.99
GBA00C	Big-Air Carburetor For 80"-100" Engines, Chrome	\$1,199.99
GBA13	Big-Air Carburetor For 103"-113" Engines, Milled	\$1,099.99
GBA13B	Big-Air Carburetor For 103"-113" Engines, Black	\$1,099.99
GBA13C	Big-Air Carburetor For 103"-113" Engines, Chrome	\$1,199.99
GBA31	Big-Air Carburetor For 117"-131" Engines, Milled	\$1,099.99
GBA31B	Big-Air Carburetor For 117"-131" Engines, Black	\$1,099.99
GBA31C	Big-Air Carburetor For 117"-131" Engines, Chrome	\$1,199.99
GBA55	Big-Air Carburetor for 139"-155" Engines, Milled	\$1,099.99
GBA55B	Big-Air Carburetor for 139"-155" Engines, Black	\$1,099.99
GBA55C	Big-Air Carburetor for 139"-155" Engines, Chrome	\$1,199.99

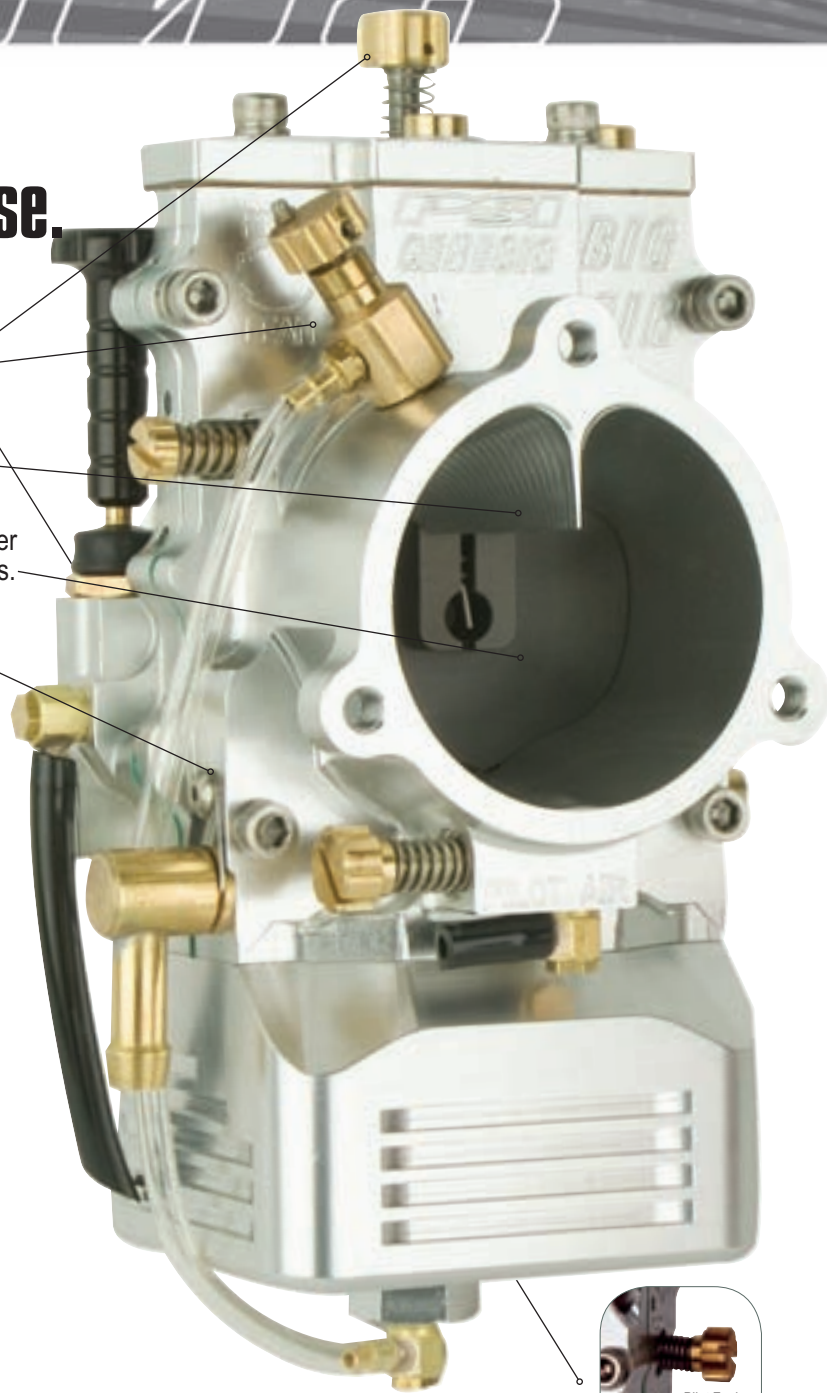

Pilot Fuel
(On Side)



More Power - By The Numbers

15

The number of ponies you can bolt on with a Big Air carb.

20

The years since all other carbs were deemed "high-tech."

100

The percent of your money back if you are not satisfied with Big Air within 60 days.

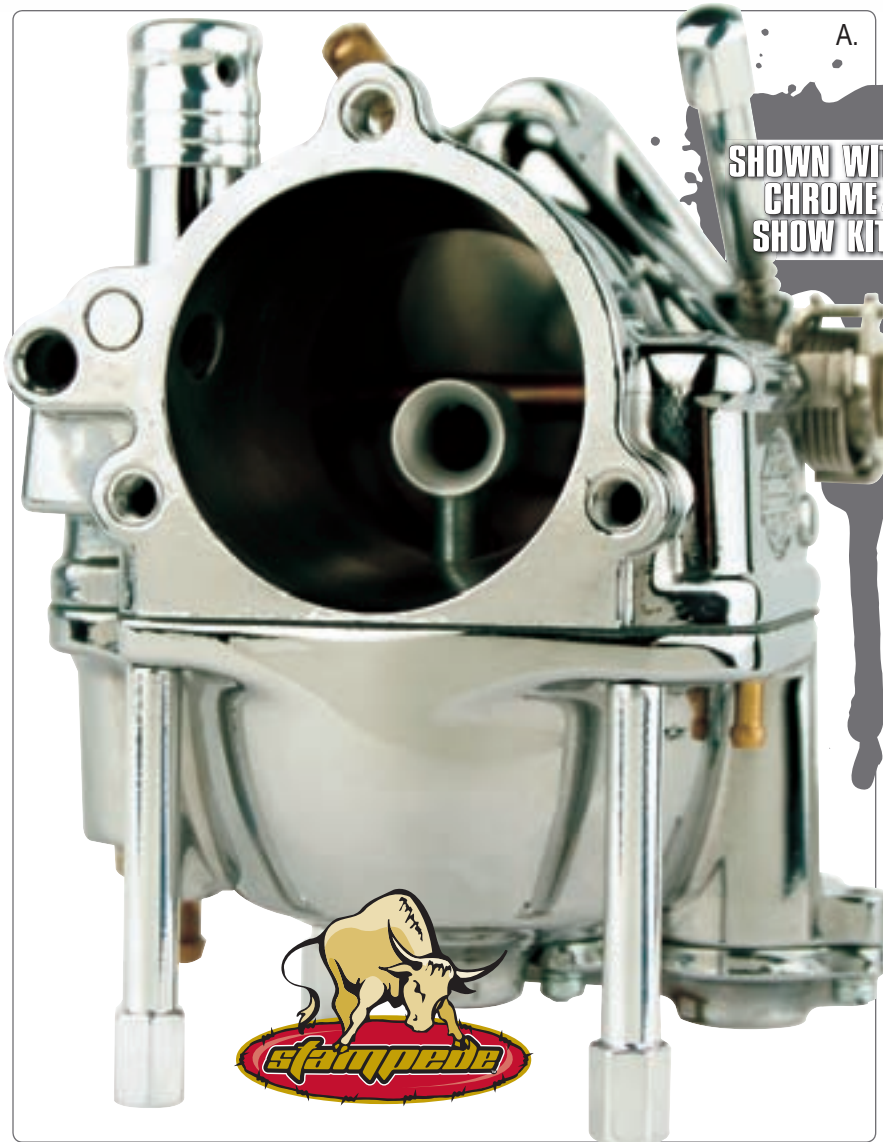

A. Stampede™ Chromed, Bored & Boosted S&S® Carbs

- Elite chrome finish, power-boosting fuel atomizer and bored throat — they are unmatched for looks and performance
- Chromed body — photo shows optional show kit with chromed bolts
- Power Booster installed to atomize fuel for razor-sharp throttle response
- Select models bored to a 1.85" throat
- Super E Carb is only available chromed and boosted
- Dress-Up Kit and Power Booster available separately

		MSRP
MC421SC	Chromed Super G (Non-Boosted & Bored)	\$579.00
MC421BC	Chromed & Boosted G, 88"-100" Engines	\$629.00
MC421C	Chromed, Bored & Boosted G, 100"+ Engines	\$669.00
MC420BC	Chromed & Boosted E, Less Than 88" Engines	\$669.00

B. Stampede™ Carb Power Booster

Atomizes the fuel mixture for razor-sharp throttle response and more power. Turn Super E and G Carbs into powerful breathers for any size motor.

MC4PE	Power Booster Kit	\$149.99
-------	-------------------	----------

C. Stampede™ Bowl Bolt Kits



Quick and easy carb adjustments! Show kit interferes with S&S® air cleaners.

ST21SK	"Blackout" Show Kit, S&S® E/G Carbs, Black Powdercoat	\$89.90
ST21BEK	"Blackout" Street Kit, S&S® E/G Carbs, Black Powdercoat	\$85.99
ST21SKP	Show Kit, S&S® E/G Carbs, Polished	\$65.99
ST21BEKP	Street Kit, S&S® E/G Carbs, Polished	\$59.99

D. S&S Cycle® Carburetors & Kits

Carburetors For:	Super E	MSRP	Super G	MSRP
Carb Only	SS110420	\$304.95	SS110421	\$319.95
'84-'92 BT	SS110407	\$484.95	SS110427	\$529.95
'93-'99 BT	SS110419	\$504.95	SS110434	\$524.95
'99-'06 BT	SS110450	\$509.95	SS110451	\$529.95
'57-'78 Ironhead	SS110404	\$466.95	SS110424	\$489.95
'79-'85 Ironhead	SS110406	\$489.95	SS110426	\$499.95
'86-'90 XL	SS110408	\$506.95	SS110428	\$519.95
'91-'03 XL	SS110409	\$514.95	SS110429	\$529.95
'04-'06 XL	SS110470	\$564.95	N/A	N/A
'94-'03 Buell®	SS110448	\$559.95	SS110449	\$569.95
'79-'84 BT w/ Std Tanks	SS110411	\$486.95	SS110431	\$499.95
'79-'84 BT Manifold Only	SS161300	\$69.95	SS162300	\$69.95
'66-'78 BT w/ Std Tanks	SS110402	\$474.95	SS110422	\$489.95
'66-'78 BT Manifold Only	SS161200	\$69.95	SS162200	\$69.95
'66-'84 BT w/ 5 Gal Tanks w/o Man.	SS110418	\$474.95	SS110438	\$484.95
'48-'64 Knuckle/Panhead	SS110401	\$499.95	N/A	N/A

F. S&S Cycle® Carburetor Rebuild Kits (Not Shown)

PART	DESCRIPTION	MSRP
SS112906	Super E Carb Body Rebuild Kit	\$34.95
SS112923	Super E Master Rebuild Kit	\$70.95
SS112918	Super E & G Accelerator Pump Rebuild Kit	\$17.95
SS112907	Super G Carb Body Rebuild Kit	\$36.95
SS112924	Super G Master Rebuild Kit	\$73.95

G. D&M Enrichment/Choke Knobs For S&S® Carbs

Extend the show-stopping style of their popular air cleaners to a carb.

PART	DESCRIPTION	MSRP
DM1300	Power Flow Knob	\$48.78
DM1100	The Spear Knob	\$48.78
DM1200	The Flat Top Knob	\$48.78

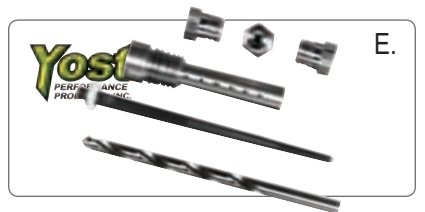
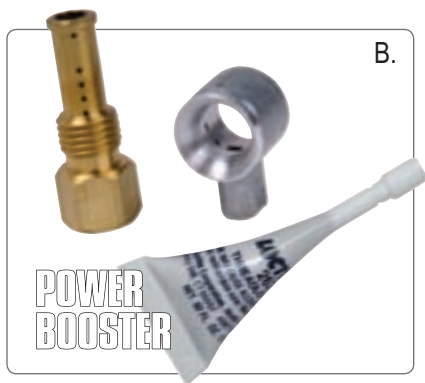

E. Yost Performance Power Tubes

Atomizes fuel to its finest form

SSPT	Power Tube For S&S® Carb	\$44.00
CVPTM	Master Kit For CV Carb	\$100.00
MKPT	Power Tube For Mikuni®	\$55.00

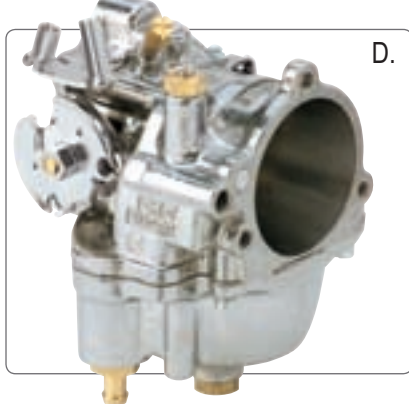



Stainless Creations "Sinister" Velocity Stacks

- Handcrafted in the USA out of show polished Stainless Steel
- Available first from MC Advantages!
- Contains a multi-layer, louvered air filter to keep your engine breathing clean
- Mount any style of Sinister Series Velocity Stack to your existing carburetor support bracket available separately below
- Includes unique mounting adapter for 360° rotation to achieve the exact look desired with one of these vicious looking stacks
- Replacement filter cartridges available

PART	DESCRIPTION	MSRP
SCVS201	Serpent Velocity Stack, Polished Stainless Steel	\$480.00
SCVS202	Devil's Tongue Velocity Stack, Polished Stainless Steel	\$480.00
SCVS203	Scorpion Velocity Stack, Polished Stainless Steel	\$480.00
SCVS204	Impaler Velocity Stack, Polished Stainless Steel	\$480.00
SCVS205	Apocalypse Velocity Stack, Polished Stainless Steel	\$480.00
SCVS206	Talon Velocity Stack, Polished Stainless Steel	\$480.00
SCVSF	Replacement Filter Cartridge	\$20.00

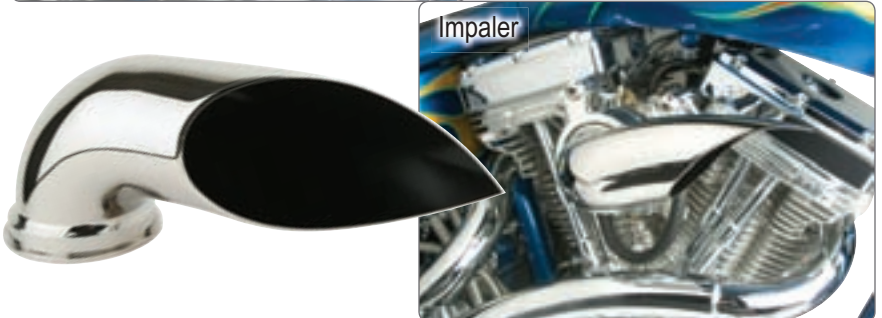

Adjustable Air Cleaner & Velocity Stack Breather Bracket

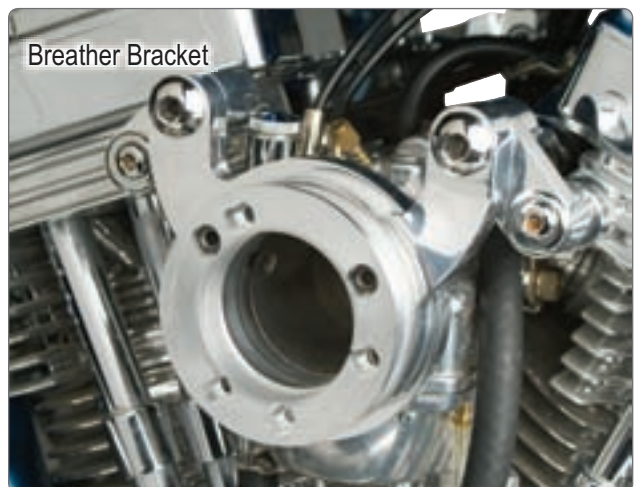

For the ultimate in flexibility, style and function when mounting aftermarket air cleaners and velocity stacks, grab one of these revolutionary designed carburetor support brackets from Stainless Creations. Made of chromed billet aluminum, this bracket adjusts from a Sportster engine size all the way up to the biggest of strokers and it incorporates internal head breathers for a clean, custom look. Mounting hardware included. Patent Pending.

PART	DESCRIPTION	MSRP
SCCSB102	Adjustable Carburetor Support Bracket For CV	\$195.00
SCCSB103	Adjustable Carburetor Support Bracket For Mikuni®	\$195.00
SCCSB101	Adjustable Carburetor Support Bracket For S&S® E/G	\$195.00
SCCSB130	Adapter For Mounting Other Brands Of Air Cleaners To The Stainless Creations Carb Support Bracket	\$125.00



A.

A. D&M Velocity Stacks

- Chrome plated velocity stack with one-piece breather support bracket
- No external breather lines
- Includes breather support bracket and all mounting hardware for most motors

PART	DESCRIPTION	MSRP
D02110	Long For CV 40mm, '92-'06 BT	\$170.22
D02120	Long For S&S® E/G '92-'06 BT	\$368.20
D02130	Long For Mikuni® 42-48mm '92-'06 BT	\$398.37
D02010	Short For CV 40mm '92-'06 BT	\$339.67
D02020	Short For S&S® E/G '92-'06 BT	\$339.67
D02030	Short For Mikuni® 42-48mm '92-'06 BT	\$371.88



B.



C.

B. Detroit Bros.® Menace Velocity Stack

- T6 aluminum, K&N® Air filter sold separately
- Can be run vertically or horizontally with excellent airflow

PART	DESCRIPTION	MSRP
DBVSM	For '84-Later w/ CV & S&S® Carbs, Polished	\$229.99

C. Goldammer Cycle Works Airtime Air Cleaner

- Designed by three-time AMD World Champion Roger Goldammer!
- 16 gauge stainless steel with cleanable foam element

PART	DESCRIPTION	MSRP
GLDAT	Airtime For CV 40mm & Delphi®, Polished	\$496.00
GLDATBR	Airtime For CV 40mm & Delphi®, Brushed	\$496.00
D040339	Adapter Ring For S&S®	\$41.27
D040335	Adapter Ring For Mikuni®	\$42.41



D. S&S® Optional Air Cleaners & Covers



Add a touch of style or patriotism to the classic S&S® Teardrop Air Cleaner design.

SS170004	Desperado Air Cleaner Cover, '84-'99 BT	\$124.95
SS170385	Patriot Air Cleaner Cover, '84-'99 BT	\$124.95
SS170117	Teardrop '93-Later BT/TC, '91-'03 XL w/ CV Carb	\$209.95

S&S® Air Cleaner Assemblies	Stock CV & EFI MSRP		S&S L, H-D®, Tillotson® Bendix®, Keihin® MSRP		Super B MSRP		Super E & G MSRP	
For Big Twin Models:								
S&S® 4.125" Bore BT (After Jan. '03)							17-0416	\$199.95
'01-Later EFI Softail®, '02-Later EFI Models (Excl. '06-Later Dyna®)	17-0450	\$209.95						
'99-Later Carbureted Models	17-0450	\$209.95					17-0403	\$199.95
'93-'99 Carbureted Models	17-0450	\$209.95					17-0404	\$199.95
'90-'92					17-0107	\$199.95	17-0399	\$199.95
'84-'89			17-0108	\$199.95	17-0107	\$199.95	17-0399	\$199.95
'66-'84 w/5 Gallon Tanks			17-0199	\$199.95	17-0099	\$199.95	17-0440	\$199.95
'66-'84			17-0199	\$199.95	17-0099	\$199.95	17-0440	\$199.95
For Sportster® and Buell® Models:								
'04-'05	17-0448	\$209.95					17-0428	\$199.95
'91-'03	17-0448	\$209.95					17-0404*	\$199.95
'88-'90					17-0107	\$199.95	17-0399	\$199.95
'86-'87			17-0108	\$199.95	17-0107	\$199.95	17-0399	\$199.95
'66-'85			17-0199	\$199.95	17-0099	\$199.95	17-0400	\$199.95
'94-Later Buell®	17-0105	\$199.95					17-0400	\$199.95

ENGINE
 FUEL SYSTEMS
 EXHAUST
 ELECTRICAL
 DRIVETRAIN
 WHEELS
 SUSPENSION
 SHEETMETAL
 FRAMES
 CONTROLS
 LIGHTING
 BAGGERS
 TOOLS
 APPAREL

A. D&M Custom Cycle "The Spear" Air Cleaners

- Premium air cleaner increases air flow 10% over OEM air cleaners
- Includes K&N® filter, 90° elbow, hardware and cover
- Requires separate breather bracket for mounting.

PART	DESCRIPTION	MSRP
DTSSCHA	360° Slots, Chrome Cover & Elbow	\$483.94
DTSSCH	180° Slots, Chrome Cover & Elbow	\$483.94
DTSSPB	360° Slots, Chrome Cover & Black Elbow	\$483.94

See MCAdvantages.com For Color & Diamond Cutting Information



B. D&M Custom Cycle "The Bullet" Air Cleaners

- All the features of The Spear but with a radiused tip
- Requires separate breather bracket for mounting

PART	DESCRIPTION	MSRP
DTSBCHA	360° Slots, Chrome Cover & Elbow	\$483.94
DTSBCH	180° Slots, Chrome Cover & Elbow	\$483.94
DTSBPB	360° Slots, Chrome Cover & Black Elbow	\$483.94

See MCAdvantages.com For Color & Diamond Cutting Information



C. D&M Custom Cycle "Power Flow" Air Cleaners

- Outperforms OEM air cleaners by 20%
- Includes K&N® filter, 90° elbow, mounting hardware and chrome billet cover with tapered or straight slots
- Requires separate breather bracket for mounting

PART	DESCRIPTION	MSRP
DPFTCH	Taper Slots, Chrome Cover & Elbow	\$483.94
DPFSCH	Straight Slots, Chrome Cover & Elbow	\$483.94

See MCAdvantages.com For Color & Diamond Cutting Information



D. D&M Custom Cycle "Raptor" Air Cleaner

- Increases air flow by 20% over OEM air cleaners
- Includes K&N® filter, 90° elbow, mounting hardware and chrome billet cover
- Requires separate breather bracket for mounting

PART	DESCRIPTION	MSRP
DTSRCHA	Raptor Air Cleaner, Chrome w/ Chrome Elbow	\$483.94

E. D&M Custom Cycle "Twister" Air Cleaner

- Increases air flow by 10% over OEM air cleaners
- Includes K&N® filter, 90° elbow, mounting hardware and chrome billet cover
- Requires separate breather bracket for mounting

PART	DESCRIPTION	MSRP
DM425	Twister Air Cleaner, Chrome w/ Chrome Elbow	\$534.00

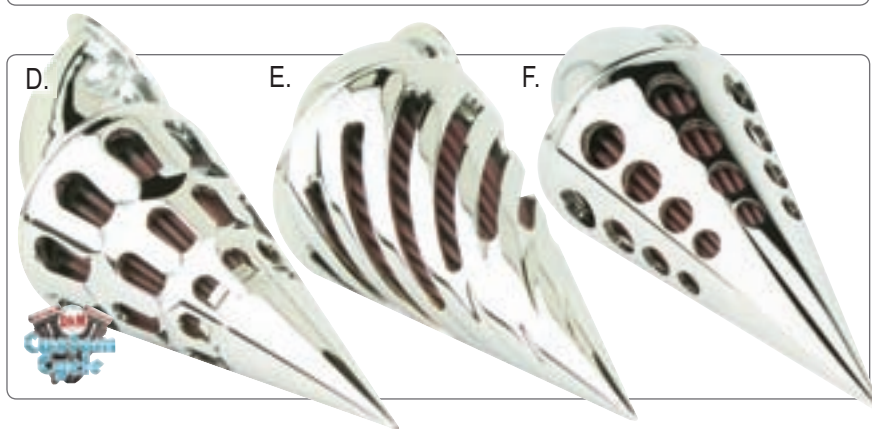

F. D&M Custom Cycle ".32 Caliber" Air Cleaner

- Increased performance over stock applications
- Requires separate breather bracket for mounting

PART	DESCRIPTION	MSRP
DM400C	.32 Caliber Air Cleaner, Chrome With Chrome Elbow	\$483.94
DM400	.32 Caliber Cone Only	\$283.35

G. D&M Custom Cycle "Power Twins" Dual Air Cleaners

A version of the Power Flow air cleaner above but in this case, doubly stub-nosed!

PART	DESCRIPTION	MSRP
D1600PT	For Dual Edelbrock®, Chrome	\$550.33
D1700PT	For Dual Weber®, Chrome	\$550.33
D1800PT	For Dual Mikuni®, Chrome	\$550.33

H. D&M Custom Cycle "Evil Twins" Dual Air Cleaners

A version of the "Spear" air cleaner above, except in this case, sinister twins!

PART	DESCRIPTION	MSRP
D1600ET	For Dual Edelbrock®, Chrome	\$550.33
D1700ET	For Dual Weber®, Chrome	\$550.33
D1800ET	For Dual Mikuni®, Chrome	\$550.33

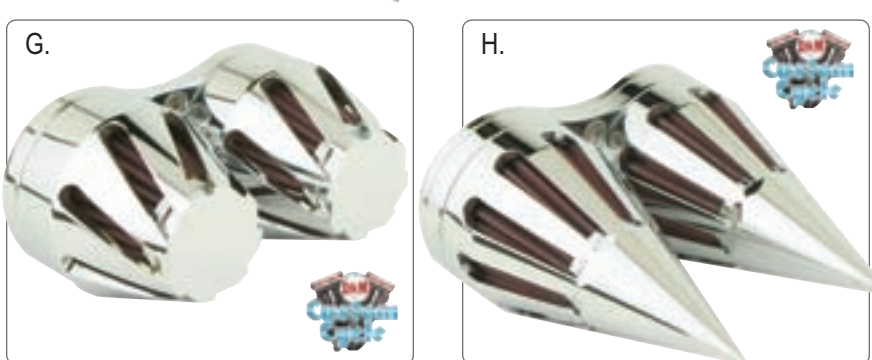



SINGLE RUNNER INTAKES ALSO AVAILABLE

A. D&M Custom Cycle Dual-Runner Intake Covers

- Available with 360° slotted Spear, Bullet, Twister, Raptor and .32 Caliber styles
- Also available in black, red, blue and green with plain or diamond-cut slots
- S&S® Dual-Runner Intake sold separately



PART	DESCRIPTION	MSRP
DM33SP	Dual Runner Spear, Chrome	\$805.31
DM33BU	Dual Runner Bullet, Chrome	\$805.31
DM33TW	Dual Runner Twister, Chrome	\$857.35
DM33RA	Dual Runner Raptor, Chrome	\$805.31
DM33CA	Dual Runner .32 Caliber, Chrome	\$805.31

See Price List For Color And Diamond-Cut Versions

S&S® Dual Bore VFI Tuned Induction Runner Kit For '95-'06 BT

SS175100	Runner Kit, Chrome	\$469.95
SS175051	Runner Kit, Burnished	\$439.95
SS175052	Runner Kit, Black	\$449.95
SS175053	Runner Kit, Polished	\$459.95
	Adapter For D&M Air Cleaner To Single-Runner Induction	Call

B. D&M Custom Cycle Hustler Air Cleaners

D&M's newest forward air cleaner design adds another look to the already popular Power Flow and Spear series of air cleaners. The Hustler also has design features to improve performance and looks with optional light kits in red, blue, green and amber. Patent pending.

PART	DESCRIPTION	MSRP
DTSHS	Hustler Air Cleaner w/ Slotted Insert	\$589.19
DTSHM	Hustler Air Cleaner w/ Maltese Cross Insert	\$589.19
DTSLSLR	Hustler Light Kit, Red LED, Fits Slotted Cap Hustler	\$55.82
DTSLSLB	Hustler Light Kit, Blue LED, Fits Slotted Cap Hustler	\$55.82
DTSLSLG	Hustler Light Kit, Green LED, Fits Slotted Cap Hustler	\$55.82
DTSLSLA	Hustler Light Kit, Amber LED, Fits Slotted Cap Hustler	\$55.82

C. D&M Custom Cycle Metric Adapters

Snug up D&M Air Cleaners to your metric ride. Chromed billet aluminum construction.

PART	DESCRIPTION	MSRP
DM500	'98-'05 Road Star®	\$247.14
DM60	Kawasaki®	\$284.40
DM44	Honda® VTX1300	\$284.18
DM45	Honda® VTX1800	\$284.18



D. D&M Custom Cycle Air Cleaner Covers By Outerwears®

PART	DESCRIPTION	MSRP
DM2301	Spear Cover, Black	\$25.20
DM2304	Bullet Cover, Black	\$25.20
DM2302	Power Flow Cover, Black	\$27.65



E. D&M Custom Cycle Crankcase Breather

- Deep chrome on billet T6061
- Works on any top breathers
- Specifically designed for 117" engines with rear rocker breathers

DM3200	Spear Breather, Chrome	\$118.63
--------	------------------------	----------

D&M Additional Accessories



D&M Breather Brackets Now Available For

**REVTECH
SPORTSTER®
METRIC**

Support Breather Brackets For:	MSRP
D02112 '93-'08 BT w/ CV 40mm(Excl '08 Touring Models)	\$164.29
D02113 '93-'08 BT w/ S&S® E/G(Excl '08 Touring Models)	\$170.22
D02114 '93-'08 BT w/ Mikuni®(Excl '08 Touring Models)	\$194.90
D02114RT RevTech®, Incl. Long Bolts, 1/2 x 13	\$261.43
D02114TC '02-Later TC w/ Mikuni®, Incl. Offset	\$214.49
D02111 XL w/ CV	\$164.29
D02110XL XL w/ S&S®	\$149.00

Steel Support Bracket For:	MSRP
D021203 '93-'02 BT (Excludes '08 Touring Models)	\$34.95

Adapters For:	MSRP
D040335 Mikuni® 42-48mm	\$42.41

D040337 CV 40mm Vertical	\$39.80
D040339 S&S® E/G Carb	\$41.27
DM500 '98-'05 Roadstar®	\$247.14
DM60 Kawasaki®	\$284.40
DM44 Honda® VTX1300	\$284.18
DM45 Honda® VTX1800	\$284.18



A. Forcewinder XR2 Air Intake System

- Incorporates Pro-Bike billet components in a high flow Forcewinder
- Cool billet and hardline breather setup that loops into the back of the filter
- A larger tube houses the temp sensor pressure fitting into the back of the filter
- Includes Outerwears® sock that can be run as a pre-filter, with virtually no HP loss

PART	DESCRIPTION	MSRP
F5013200CL	XR2 For '92-'99 Evolution®, Wrinkle Black Elbow	\$395.95
F501322T	XR2 For Carb TC88® & '01-Later FI TC, Show Pol. Elbow	\$329.95

A.



B. Forcewinder XR Air Cleaner

- The original high performance forward-mounted air cleaner
- Fits Buell®, XL, BT and Twin Cams
- Features high performance and polished aluminum construction
- Complete with both K&N® intake and PCV filters, stainless allen bolts, gaskets and Outerwears® Black Dry Charger weather inhibiting filter wrap
- Adapters available to fit S&S® E and G and Mikuni HSR 42/45 carbs
- If converting from an OEM setup, an aftermarket mounting bracket and breather kit will be necessary. Also available in gloss black or white

PART	DESCRIPTION	MSRP
F5013BK	XR Forcewinder Air Cleaner, Black	\$255.95
F5013	XR Forcewinder Air Cleaner, Polished	\$251.95

B.



C. Force Air Cleaner Covers

Got the breather with Force — now add some flare! Show off that Forcewinder with these chrome covers.

PART	DESCRIPTION	MSRP
F5061200	Tribal Thunder (Top) For Force Filter	\$160.95
F5066150	Hot Rod Flame For Force Filter	\$160.95
F5067	Horizontal Skull w/Cross Bones For K&N® Filter	\$160.95
F5067100	Horizontal Skull w/Cross Bones For Force Filter	\$160.95
F5068	Vertical Skull For Force Filter, Chrome	\$160.95
F5068100	Vertical Skull For K&N® Filter, Chrome	\$160.95

C.



D. Force Air Cleaner "Scum Bag" Cover

Protect your investment with this vinyl scum bag. **Remove before riding.**

F5017100BL	Blue Scum Bag	MSRP: \$38.50
------------	---------------	---------------

E. Force Air Cleaner Pre-Filters & Drycharger Covers

- Prefilter to prefilter incoming air with fine micron holes
- Repels the incoming water, yet lets motor breathe freely

PART	DESCRIPTION	MSRP	PART	DESCRIPTION	MSRP
F5017L	Blue	\$32.95	F5017R	Red	\$32.95
F5017P	Purple	\$32.95	F5017Y	Yellow	\$32.95
F5017	Pre Filter Sock For XR-2 & Non-Big Daddy Filters, Black	\$32.95			
F501750	Pre Filter Sock For K&N® Big Daddy Filter, Black	\$32.95			

D.

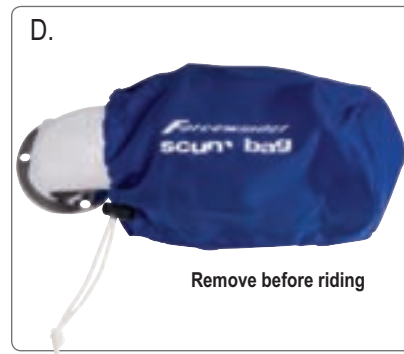

Remove before riding

E.



F. Force Carburetor Adapters & Brackets

PART	DESCRIPTION	MSRP
F5011200SP	S&S® E and G Carburetor Adapter, Billet	\$57.95
F5015200SP	Mikuni® HS 42 /45 Adapter, Billet	\$66.95

Gloss Black Breather Brackets For: (Wrinkle & Polished Also Available, Call)

F5020100BK	'92-'99 Evolution® Head Breather w/ CV40	\$238.50
F5020150BK	'92-'99 Evolution® Head Breather w/ Mikuni® 42/45/48	\$312.72
F5020200BK	'92-'99 Evolution® Head Breather w/ S&S® E/G	\$312.72
F5020125BK	'99-'07 Twin Cam w/ CV40/EFI	\$238.50
F5020175BK	'99-'07 Twin Cam w/ Mikuni® 42/45/48	\$312.72
F5020225BK	'99-'07 Twin Cam w/ S&S® E/G	\$312.72
F5020300BK	'86-Later Evolution® XL w/ CV40	\$238.50
F5020325BK	'86-Later Evolution® XL w/ Mikuni® 42/45/48	\$312.72
F5020350BK	'86-Later Evolution® XL w/ S&S® E/G	\$312.75

F.

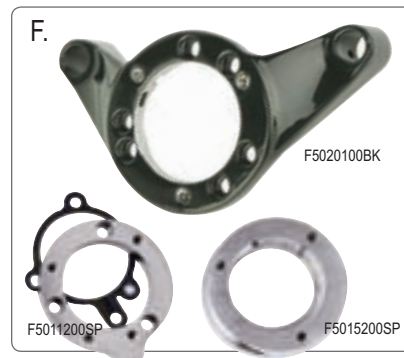

G.

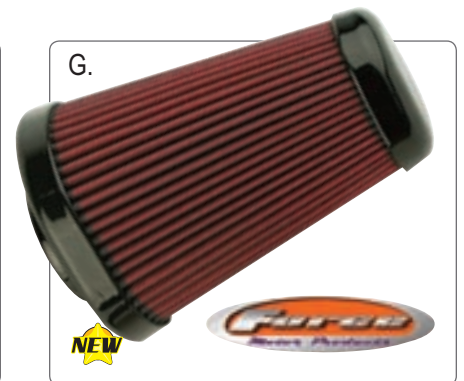

G. Force Air Cleaner Billet Replacement Filters

- Sculpted billet aluminum end cap with integral high-flow filter medium
- Easy wash and re-oil for a lifetime of service

PART	DESCRIPTION	MSRP
F5009100	Force Pro Series Billet XR Air Filter, Polished	\$165.90
F5009100B	Force Pro Series Billet XR Air Filter, Gloss Black	\$165.90
F5009100W	Force Pro Series Billet XR Air Filter, Wrinkle Black	\$165.90



Shown w/ All Black Billet Option

A. Forcewinder Dominator Air Intake Systems

- Couples the high performance Forcewinder with an internal breathing mount for tight looks, performance and increased leg room
- Pro Bike Polished Billet air filter and Dominator mount are made from investment cast aluminum — then are machined and show polished or powdercoated
- Includes mounting hardware, breather bolts, Outerwears pre filter and gaskets
- Includes matching breather bracket

For BT & TC With CV 40 Carbs Or Delphi® (Excludes '08 Touring) EFI:		
F5013300	For '92-'99 Head Breather BT, Polished	\$405.53
F5013300PS	For '92-'99 Head Breather BT, Pro Bike Polished Billet	\$491.84
F5013300PSB	For '92-'99 Head Breather BT, Black Billet Option	\$571.25
F5013400	For '99-'08 Twin Cam, Polished	\$405.53
F5013400PS	For '99-'08 Twin Cam, Pro Bike Polished Billet	\$491.84
F5013400PSB	For '99-'08 Twin Cam, Black Pro Bike Polished Billet	\$571.25
F5013500	For '86-Later Carbureted XL w/ CV 40, Polished	\$405.53
F5013500PS	For '86-Later Carbureted XL w/ CV 40, Pro Bike Pol. Billet	\$491.84
F5013500PSB	For '86-Later Carbureted XL w/ CV 40, Black Billet Option	\$571.25

For BT & TC With CV 40 Carbs Or Round EFI:		
F5013325	For '92-'99 Head Breather BT, Polished	\$484.23
F5013325PS	For '92-'99 Head Breather BT, Pro Bike Polished Billet	\$538.57
F5013325PSB	For '92-'99 Head Breather BT, Black Billet Option	\$495.50
F5013425	For '99-'08 Twin Cam, Polished	\$484.23
F5013425PS	For '99-'08 Twin Cam, Pro Bike Polished Billet	\$538.57
F5013425PSB	For '99-'08 Twin Cam, Black Pro Bike Polished Billet	\$495.50
F5013525	For Carbureted '86-Later XL, Polished	\$484.23
F5013525PS	For Carbureted '86-Later XL, Pro Bike Polished Billet	\$495.50
F5013525PSB	For Carbureted '86-Later XL, Black Billet Option	\$538.57

For BT & TC With CV 40 Carbs Or Round EFI:		
F5013350	For '92-'99 Head Breather BT, Polished	\$484.23
F5013350PS	For '92-'99 Head Breather BT, Pro Bike Polished Billet	\$538.57
F5013350PSB	For '92-'99 Head Breather BT, Black Billet Option	\$495.50
F5013450	For '99-'08 Twin Cam, Polished	\$484.23
F5013450PS	For '99-'08 Twin Cam, Pro Bike Polished Billet	\$538.57
F5013450PSB	For '99-'08 Twin Cam, Black Pro Bike Polished Billet	\$495.50
F5013550	For Carbureted '86-Later XL, Polished	\$484.23
F5013550PS	For Carbureted '86-Later XL, Pro Bike Polished Billet	\$495.50
F5013550PSB	For Carbureted '86-Later XL, Black Billet Option	\$538.57



SS1060248 Covers \$36.45

B. S&S® Single Bore Tuned Induction System

- Bolt on performance — increased torque and power
- Chrome, wrinkle black powdercoat, or natural finish
- Air filter area almost two times that of an S&S® teardrop air cleaner
- Adapter brackets available for many engine/fuel system combinations

PART	DESCRIPTION	MSRP
SS171005	Chrome, Match With Adapter Below	\$324.95
SS171003	Wrinkle Black, Match With Adapter Below	\$259.95
SS171001	Natural, Match With Adapter Below	\$239.95

ADAPTERS:					
PART	DESCRIPTION	MSRP	PART	DESCRIPTION	MSRP
For Engines w/ S&S® E/G Carb:			For Engines w/ S&S® Single Bore EFI		
SS171040	S&S® T124/V124	\$409.95	SS171046	S&S® T124/V124	\$374.95
SS171041	'84-Later BT	\$409.95	SS171047	'84-Later BT	\$374.95
SS171043	'86-'03 XL	\$409.95	For Engines w/ '01-Later Delphi® EFI		
For Engines w/ CV Carb:			SS171042	'99-Later BT	\$374.95
SS171042	'84-Later BT	\$374.95			



C. Bulletproof® Spade & Maltese Air Cleaners

- Billet aluminum air cleaners w/ cleanable filter element
- For CV carbs; S&S® and Mikuni® require separate adapter bracket

PART	DESCRIPTION	MSRP
BPACSC	Spade Air Cleaner, Chrome	\$219.99
BPACSB	Spade Air Cleaner, Black w/ Natural Edges	\$219.99
BPACMC	Maltese Cross Air Cleaner, Chrome	\$219.99
BPACMB	Maltese Cross Air Cleaner, Black w/ Natural Edges	\$219.99
BPACRC	Round Maltese Cross Air Cleaner, Chrome	\$219.99
D040339	Adapter Ring For S&S®	\$41.27
D040335	Adapter Ring For Mikuni®	\$42.41

ENGINE
 FUEL SYSTEMS
 EXHAUST
 ELECTRICAL
 DRIVETRAIN
 WHEELS
 SUSPENSION
 SHEETMETAL
 FRAMES
 CONTROLS
 LIGHTING
 BAGGERS
 TOOLS
 APPAREL

A. Crime Scene Choppers "Rapide" Air Cleaner

- Super vintage air cleaner with super durable construction
- Includes air cleaner body, backing plate, polished brass grill, two filter elements, filter support and all stainless hardware

PART	DESCRIPTION	MSRP
CSC700	Satin Finish w/ Highlights & Polished Brass Grille	\$319.00
CSC701	Chrome	\$349.00

A.



B. Crime Scene Choppers "Speedline" Air Cleaner

- Signature fins that taper into the body of the air cleaner
- Complete with a brushed stainless backing plate, stainless hardware and washable Uni-Filter filter — replacement air filters are available
- Mounts to carburetor or throttle body via a stainless steel backing plate which is perforated to increase airflow

PART	DESCRIPTION	MSRP
CSC655	Chrome, CV and S&S® Super E/G	\$399.00
CSC651	Satin w/ Polished Fins, CV and S&S® Super E/G	\$299.00
CSC661	Chrome, '01-Later H-D® EFI	\$399.00
CSC666	Satin, '01-Later H-D® EFI	\$299.00
CSC656	CSC Air Cleaners Replacement Foam Element	\$20.00

B.



C. Crime Scene Choppers "First Offense" Air Cleaner

- Bronze mesh insert, teardrop-shaped intake holes.
- Complete with a skeletonized brushed stainless backing plate, stainless hardware and washable Uni-Filter™ foam element
- Fitments also available for Magneti-Marelli FI & Linkert, call for details

PART	DESCRIPTION	MSRP
CSC652	Satin w/ Bronze Inserts, Fits CV/S&S Super E/G	\$299.00
CSC653	Polished w/ Bronze Inserts, Fits CV/S&S Super E/G	\$399.00
CSC654	Chrome w/ Bronze Inserts, Fits CV/S&S Super E/G	\$399.00
CSC657	Satin w/ Bronze Inserts, '01-Later EFI	\$299.00
CSC658	Polished w/ Bronze Inserts, '01-Later EFI	\$339.00
CSC659	Chrome w/ Bronze Inserts, '01-Later EFI	\$399.00
CSC656	CSC Air Cleaners Replacement Foam Element	\$20.00

C.



Custom painted satin version

D. S&S® Quick Set Up Exhaust & Intake Kit

- A quick 10 horsepower for about a small amount of money!
- Contains a pair of S&S performance mufflers, an S&S teardrop air cleaner, and a jet kit for carbureted models
- No engine work to do, and everything needed is included in the kit!
- Kits for '07-Later models do not include jet kits
- Make more power by making it easier to get air into the engine with either a high flowing S&S teardrop air cleaner or the new single throat tuned induction system
- Also makes it easier for exhaust to exit through low restriction mufflers
- Kits with the single bore tuned induction system provide an added kick due to the increased filter area and the effect of the tuned induction

PART	DESCRIPTION	MSRP
Kits w/ Tapered Mufflers For:	Teardrop Air Cleaner	Tuned Induction
'87-'03 XL	SS1061010 \$559.95	N/A
'04-'06 XL	SS1061011 \$574.95	N/A
'95-'05 Dyna®	SS1061012 \$584.95	SS556514 \$1,139.95
'06-'07 Dyna®	SS1061013 \$584.95	SS556517 \$1,014.95
'00-'06 Softail®, Shorty	SS1061014 \$644.95	SS556515 \$1,139.95
'00-'06 Softail®, Shotgun	SS1061015 \$644.95	SS556516 \$1,139.95
'07 Softail® Standard, Shorty	SS1061016 \$644.95	SS556521 \$1,079.95
'07 Fat Boy® & Deuce®, Shotgun	SS1061017 \$644.95	SS556523 \$1,079.95
'07 Softail® Deluxe, Shotgun	SS1061018 \$644.95	SS556525 \$1,079.95
Kits w/ Slash-Cut Mufflers For:	Teardrop Air Cleaner	Tuned Induction
'87-'03 XL	SS1061001 \$559.95	N/A
'04-'06 XL	SS1061001 \$574.95	N/A
'95-'05 Dyna®	SS1061002 \$584.95	SS556518 \$1,139.95
'06-'07 Dyna®	SS1061003 \$584.95	SS556527 \$1,014.95
'00-'06 Softail®, Shorty	SS1061004 \$644.95	SS556519 \$1,139.95
'00-'06 Softail®, Shotgun	SS1061005 \$644.95	SS556520 \$1,139.95
'07 Softail® Standard, Shorty	SS1061006 \$644.95	SS556522 \$1,079.95
'07 Fat Boy® & Deuce® Shotgun	SS1061007 \$644.95	SS556524 \$1,079.95
'07 Softail® Deluxe, Shotgun	SS1061008 \$644.95	SS556526 \$1,079.95
Kits w/ SPO Mufflers For:	Teardrop Air Cleaner	Tuned Induction
'95-'06 Carb & '02-'07 FI Baggers	SS1061019 \$839.95	SS556507 \$1,354.95

D.



SS1061013 For Sportster®



SS1061013 For Softail®



SS1061013 For Dyna®



SS556507 For Baggers



A.

A. S&S® Stainless Performance Oval (SPO™) Mufflers

- Many compare the exhaust note of the standard SPO to the pleasing low rumble of a late '60s muscle car — but at a reasonable volume that is not likely to get the neighbors upset
- Makes as much power as much louder competitive performance mufflers
- Avoid covering the bike's audio system!
- A high temperature flat black powdercoat material capable of withstanding the exhaust temperatures of an S&S T124 engine was applied to the baffle flange — this hides soot, keeping the exhaust looking cleaner
- For even a little quieter, but with more power than the stock exhaust, the separate accessory baffle will reduce the noise by about 3 dB
- S&S® 80 dB SPO™ Mufflers meet the EPA 80 dB drive-by test requirements
- Testing at S&S with an otherwise stock 2007 FLHTC showed these new mufflers to not only be quiet, but to provide a boost in power at the same time
- Note: S&S 80 dB SPO mufflers may not conform to EPA standards if installed on a vehicle with a modified engine
- Mufflers are tamper proof in accordance with EPA regulations

SS1060116	Standard SPO Mufflers	\$594.95
SS1060117	Quiet Baffle For Standard SPO Mufflers	\$149.95
SS556634	80 dB SPO Mufflers	\$694.95

B. Martin Bros.® Bag Daddy Exhaust Pipes

- These fully-shielded 2.25" pipes merge into on 3.5" stock-mount pipe
- Punched out 10.2 more HP and 9 more ft lbs. out of a stock '07 touring model

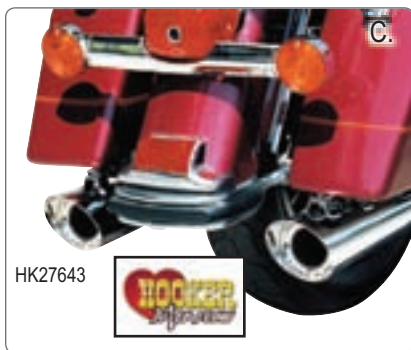

C. Hooker® Exhaust For Baggers

HK27624	07-Later 96"+, 49-State, True Dual, Slash Cut, Chrome	\$1,010.20
HK27724	07-Later 96"+, 49-State, True Dual, Turn-Out, Chrome	\$1,010.20

Tuned Flow® Slip-Ons
 These systems work with OE pipes only

HK27640	Straight-Cut, '85-'94 FL	\$520.23
HK27642	Straight-Cut, '95-'05 FL	\$520.23
HK27641	Slash-Cut, '85-'94 FL	\$520.23
HK27643	Slash-Cut, '95-'05 FL	\$520.23



For LSD '86-Later Bagger Models Unless Noted		MSRP
MB028P	Chrome	\$799.99
MB028PB	Ceramic Black	\$799.99

D. S&S® Slip-On Performance Muffler Kits

- Increase the horsepower of ANY stock Big Twin with these chrome mufflers
- Add up to 8 horses and 5 ft. lb. of torque!
- Great for big inch engines with excellent low and midrange torque
- May require rejetting or recalibration of your EFI — These do not conform to U.S. EPA noise emission standards

Slip-On Exhaust For:		MSRP
SS556005	'95-Later Dyna®, Slash-Cut	\$324.95
SS556035	'95-Later Dyna®, Tapered	\$324.95
SS556006	'00-'06 Shotgun Softail®, Slash-Cut	\$389.95
SS556036	'00-'06 Shotgun Softail®, Tapered	\$389.95
SS556007	'00-'06 Shorty Softail®, Slash-Cut	\$389.95
SS556037	'00-'06 Shorty Softail®, Tapered	\$389.95
SS556041	'07-Later Shorty Softail®, Slash-Cut	\$389.95
SS556040	'07-Later Shorty Softail®, Tapered	\$389.95
SS556043	'07-Later Shotgun Fat Boy® & Deuce®, Slash-Cut	\$389.95
SS556042	'07-Later Shotgun Fat Boy® & Deuce®, Tapered	\$389.95
SS556043	'07-Later Shotgun Softail® Deluxe, Slash-Cut	\$389.95
SS556042	'07-Later Shotgun Softail® Deluxe, Tapered	\$389.95
SS556008	'87-'03 Sportster®, Slash-Cut	\$324.95
SS556038	'87-'03 Sportster®, Tapered	\$324.95
SS556031	'04-Later Sportster®, Slash-Cut	\$339.95
SS556039	'04-Later Sportster®, Tapered	\$339.95



Martin Bros.® Curb Feelers Exhaust Pipes

- Bell-like billet aluminum tips for race-inspired looks
- Stepped from 1.75" to 2", tranny mount
- Includes heat shields and removable baffles

For '86-'06 Softail® Unless Noted		MSRP
MB015P	LSD, Chrome	\$699.00
MB015PS	LSD, Chrome For '07 Models	\$699.00
MB015PCC	LSD, Chrome w/ Internal Ceramic	\$829.00
MBE015HSL	Heat Shields For LSD	\$157.50
MB015RP	RSD, Chrome	\$699.00
MB015RPCC	RSD, Chrome w/ Internal Ceramic	\$829.00
MBE015HS	Heat Shields For RSD	\$157.50



Martin Bros.® Medustas Exhaust Pipes

- Now available for both LSD and RSD
- Stepped from 1.75" to 2", tranny mount
- Includes heat shields and removable baffles

For '86-'06 Softail® Unless Noted		MSRP
MB002P	LSD, Chrome	\$699.00
MB002PS	LSD, Chrome For '07 Models	\$789.00
MB002PCC	LSD, Chrome w/ Internal Ceramic	\$829.00
MBE002HS	Heat Shields For LSD	\$157.50
MB003RP	RSD, Chrome	\$699.00
MB003RPCC	RSD, Chrome w/ Internal Ceramic	\$829.00
MBE003HS	Heat Shields For RSD	\$157.50



Martin Bros.® Slickstas Exhaust Pipes

- The original Martin Bros.® Exhaust!
- Stepped from 1.75" to 2" to 2.25", frame mount
- Includes removable baffles

For LSD '86-'06 Softail® Unless Noted		MSRP
MB001	LSD, Chrome	\$699.00
MB001CC	LSD, Chrome w/ Internal Ceramic	\$829.00
MB001CHB	LSD, Two Tone Chrome & Ceramic	\$771.00
MB001B	LSD, Ceramic Black	\$699.00
MB001R	RSD, Chrome	\$699.00
MB001RCC	RSD, Chrome w/ Internal Ceramic	\$829.00
MB001RCH	RSD, Two Tone Chrome & Ceramic	\$771.00
MB001RB	RSD, Ceramic Black	\$699.00



Martin Bros.® Trendkills Exhaust Pipes

- Wide tires require a bracket spacer
- Stepped from 1.75" to 2", tranny mount
- Includes removable baffles

For '86-'06 Softail® Unless Noted		MSRP
MB011	LSD, Chrome	\$699.00
MB011CC	LSD, Chrome w/ Internal Ceramic	\$829.00
MB011CH	LSD, Two Tone Chrome & Ceramic	\$771.00
MB011B	LSD, Ceramic Black	\$699.00
MB012R	RSD, Chrome	\$699.00
MB012RCC	RSD, Chrome w/ Internal Ceramic	\$829.00
MB012RCH	RSD, Two Tone Chrome & Ceramic	\$699.00
MB012RB	RSD, Ceramic Black	\$771.00



Martin Bros.® Daisycutter Exhaust Pipes

- Stepped from 1.75" to 2.25", frame mount
- Includes heat shields (excludes Dyna®) and removable baffles

For '86-'06 Softail® Unless Noted		MSRP
MB008P	LSD, Chrome	\$699.00
MB008P	LSD, Chrome For '07 Models	\$699.00
MB008PCC	LSD, Chrome w/ Internal Ceramic	\$829.00
MB018RP	RSD, Chrome	\$699.00
MB018RPCC	RSD, Chrome w/ Internal Ceramic	\$829.00
MBE008HS / 018HS	LSD / RSD Heat Shields	\$157.50
MB008D	For Dyna®, Chrome	\$599.99
MB008DCC	For Dyna®, Chrome w/ Internal Cer.	\$829.00
MB008DCHB	For Dyna®, Two Tone Chrome & Cer.	\$771.00
MB008DB	For Dyna®, Ceramic Black	\$699.00



Martin Bros.® Collector Exhaust Pipes

- Possibly the biggest, baddest pipe the boys have ever made!
- Stepped from 1.75" to 3.5", tranny mount
- Includes O2 sensor port, heat shields and removable baffles

For '86-Later Softail® Unless Noted		MSRP
MB024PS	LSD, Chrome	\$799.99
MB024PSB	LSD, Black Ceramic, Chrome Shields	\$799.99
MBBUNG	Bung Plug For '86-'06 Models	\$15.50

For '07-Later Dyna® Unless Noted		MSRP
MB024DPS	Chrome	\$799.99
MB024DPSB	Black Ceramic w/ Chrome Shields	\$799.99
MBBUNG	Bung Plug For '86-'06 Models	\$15.50



Martin Bros.® Slickstas II Exhaust Pipes

- The original Slickstas as a cool 2-into-1!
- Stepped from 1.75" to 2" to 3", tranny mount

For '86-'06 Softail® Unless Noted		MSRP
MB006	LSD, Chrome	\$699.00
MB006CC	LSD, Chrome w/ Internal Ceramic	\$829.00
MB006CHB	LSD, Two Tone Chrome & Ceramic	\$771.00
MB006B	LSD, Ceramic Black	\$699.00



Martin Bros.® Draggesters Exhaust Pipes

- Stepped from 1.75" to 2" to 3", tranny mount
- Wide tires require a bracket spacer

For '86-'06 Softail® Unless Noted		MSRP
MB021	LSD, Chrome	\$699.00
MB021CC	LSD, Chrome w/ Internal Ceramic	\$829.00
MB021CHB	LSD, Two Tone Chrome & Ceramic	\$771.00
MB021B	LSD, Ceramic Black	\$699.00



Martin Bros.® WTF Exhaust Pipes

- Stepped from 1.75" to 2" to 3", frame mount
- Includes heat shields and removable baffles

For '86-'06 Softail® Unless Noted		MSRP
MB004P	LSD Chrome	\$699.00
MB004PS	LSD, Chrome For '07 Models	\$789.00
MB004PCC	LSD, Chrome w/ Internal Ceramic	\$829.00
MBE004HS	Heat Shields For LSD	\$157.50



A. Martin Bros.® EXHAUST Pipes

All Martin Bros. Pipes are available in chrome, chrome with internal ceramic coating, duo-tone chrome and matte black ceramic as well as all-matte black ceramic. Duo-tone and matte black models require additional lead time. A 1/2" spacer is included in the box for custom mounting. Please state the make, model and engine the pipes are being ordered for.

Pipes with O2 sensor ports do not include a bung for '86-'06 models. MBBUNG bung plug is available as a separate part number.



Martin Bros.® Money Shots Exhaust Pipes

- A real eye-grabber with billet exhaust tips
- Stepped from 1.75" to 2", tranny mount
- Includes O2 sensor port, heat shields and removable baffles

For '86-Later Softail® Unless Noted		MSRP
MB023PS	LSD, Chrome	\$799.99
MB023PSB	LSD, Black Ceramic, Chrome Shields	\$799.99
MBBUNG	Bung Plug For '86-'06 Models	\$15.50



Martin Bros.® Shockwaves Exhaust Pipes

- Smooth, almost liquid looks
- Stepped from 1.75" to 2", tranny mount
- Includes O2 sensor port, heat shields and removable baffles

For '86-Later Softail® Unless Noted		MSRP
MB022PS	LSD, Chrome	\$799.99
MB022PSB	LSD, Black Ceramic, Chrome Shields	\$799.99
MB022PSCC	LSD, Chrome w/ Internal Ceramic	\$929.99
MB022PSCCHB	LSD, Two Tone Chrome & Ceramic	\$871.99
MBBUNG	Bung Plug For '86-'06 Models	\$15.50



Martin Bros.® So-Dals Exhaust Pipes

- Inspired on the street, deep in the heart of Texas!
- Stepped from 1.75" to 2", tranny mount
- Includes O2 sensor port, heat shields and removable baffles

For '86-Later Softail® Unless Noted		MSRP
MB026PS	LSD, Chrome	\$799.99
MB026PSB	LSD, Black Ceramic, Chrome Shields	\$799.99
MB026DPS	For Dyna®, Chrome	\$799.99
MB026DPSB	For Dyna®, Black Cer. w/ Chr. Shields	\$799.99

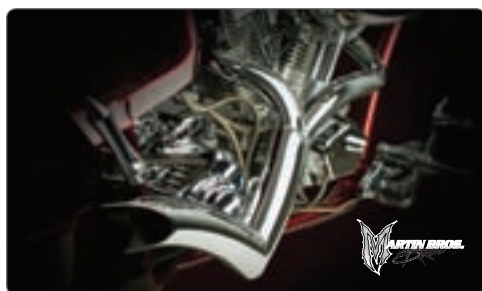

Martin Bros.® Zig-Zags Exhaust Pipes

- A new direction for Martin Bros.®!
- Stepped from 1.75" to 3", tranny mount
- Wide tires require a bracket spacer

For '86-'06 Softail® Unless Noted		MSRP
MB020R	RSD, Chrome	\$699.00
MB020RCC	RSD, Chrome w/ Internal Ceramic	\$829.00
MB020RCH	RSD, Two Tone Chrome & Ceramic	\$771.00
MB020RB	RSD, Ceramic Black	\$699.00



Martin Bros.® Zoomies Exhaust Pipes

- Bolt on a big bellow!
- Stepped from 1.75" to 3", tranny mount
- Wide tires require a bracket spacer

For '86-'06 Softail® Unless Noted		MSRP
MB019R	RSD, Chrome	\$699.00
MB019RCC	RSD, Chrome w/ Internal Ceramic	\$829.00
MB019RCH	RSD, Two Tone Chrome & Ceramic	\$771.00
MB019RB	RSD, Ceramic Black	\$699.00

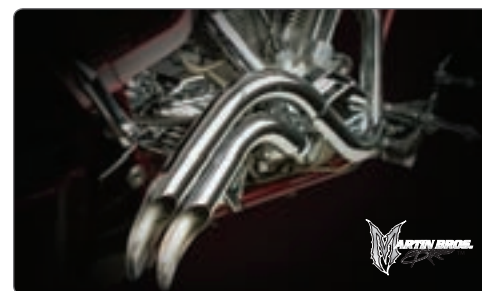

Martin Bros.® Trixstas Exhaust Pipes

- Another MC Advantages exclusive!
- Stepped from 1.75" to 2", tranny mount
- Includes heat shields and removable baffles

For '86-'06 Softail® Unless Noted		MSRP
MB017RP	RSD, Chrome	\$699.00
MB017RPCC	RSD, Chrome w/ Internal Ceramic	\$829.00
MB017HS	RSD, Two Tone Chrome & Ceramic	\$157.50



Martin Bros.® Skirtliftas II Exhaust Pipes

- Upswept pipe with angle-cut tips & removable baffles
- Stepped from 1.75" to 2", tranny mount

For '86-'06 Softail® Unless Noted		MSRP
MB014R	RSD, Chrome	\$599.00
MB014RCC	RSD, Chrome w/ Internal Ceramic	\$729.00
MB014RCH	RSD, Two Tone Chrome & Ceramic	\$671.00
MB014RB	RSD, Ceramic Black	\$599.00



Martin Bros.® Ghetto Blasters Exhaust Pipes

- Designed for American IronHorse®
- Stepped from 1.75" to 3", tranny mount

For '86-'06 Softail® Unless Noted		MSRP
MB013R	RSD, Chrome	\$699.00
MB013RCC	RSD, Chrome w/ Internal Ceramic	\$829.00
MB013RCH	RSD, Two Tone Chrome & Ceramic	\$771.00
MB013RB	RSD, Ceramic Black	\$699.00



Martin Bros.® So-Dals Exhaust Pipes For XL

- Stepped from 1.75" to 2", frame mount
- Includes O2 sensor port, heat shields and removable baffles

For '02-Later Sportster® Unless Noted		MSRP
MB126SPS	Chrome	\$799.99
MB126SPSB	Black Ceramic w/ Chrome Shields	\$799.99
MBBUNG	Bung Plug For '02-'06 Models	\$15.50



Martin Bros.® Blunts Exhaust Pipes For XL

- Stepped from 1.75" to 2", frame mount
- Includes O2 sensor port, heat shields and removable baffles

For '02-Later Sportster® Unless Noted		MSRP
MB025SPS	Chrome	\$799.99
MB025SPSB	Black Ceramic w/ Chrome Shields	\$799.99
MBBUNG	Bung Plug For '02-'06 Models	\$15.50



Martin Bros.® Two Downs Exhaust Pipes For XL

- Stepped from 1.75" to 2", frame mount
- Includes O2 sensor port, heat shields and removable baffles

For '02-Later Sportster® Unless Noted		MSRP
MB027SPS	Chrome	\$799.99
MB027SPSB	Black Ceramic w/ Chrome Shields	\$799.99
MBBUNG	Bung Plug For '02-'06 Models	\$15.50



Martin Bros.® Trendkills Exhaust Pipes For XL

- Stepped from 1.75" to 2", frame mount
- Includes O2 sensor port, heat shields and removable baffles

For '02-Later Sportster® Unless Noted		MSRP
MB011SPS	Chrome	\$799.99
MB011SPSB	Black Ceramic w/ Chrome Shields	\$799.99
MBBUNG	Bung Plug For '02-'06 Models	\$15.50



- Handcrafted and hand-polished in the USA from .065" stainless steel
 - Includes tranny mounting brackets
 - **Spacer is required for bikes with offsets**
 - Allow up to four weeks for delivery on special orders
- IMPORTANT NOTES:**
- Specify engine size when ordering 2-into-1 styles to ensure fitment
 - Re-jet your carburetor when installing new exhausts
 - Blue Job Metal Polish is highly recommended to clean pipes BEFORE BURN-IN and anytime to remove heat related discoloration.



Stainless Creations Chaos III Uncrossed Exhaust

- Separate baffles available — see info on next page

SCEC3UR	For RSD, Evolution®	\$775.00
SCEC3UL	For LSD, Evolution®	\$775.00
SCEC3UTC	For LSD, TC	\$775.00

ADD S For Brushed



Stainless Creations Havoc Exhaust

- Separate baffles available — see info on next page

SCEHR	For RSD, Evolution®	\$1,125.00
SCEHL	For LSD, Evolution®	\$1,125.00
SCEHTC	For LSD, TC	\$1,125.00

ADD S For Brushed



Stainless Creations Vector Exhaust

- Completely new look in exhaust design
- MC Advantages exclusive product
- Big Dog® LSD styles may interfere with air cleaners

SC02001PS	For RSD, Evolution®, Polished	\$1,000.00
SC02001BR	For RSD, Evolution®, Brushed	\$1,000.00
SC02002PS	For LSD, Evolution®, Polished	\$1,000.00
SC02002BR	For LSD, Evolution®, Brushed	\$1,000.00
SC02007PS	For LSD, Twin Cam, Polished	\$1,000.00
SC02007BR	For LSD, Twin Cam, Brushed	\$1,000.00
SC02008PS	For RSD, Big Dog®, Polished	\$1,000.00
SC02008BR	For RSD, Big Dog®, Brushed	\$1,000.00
SC02009PS	For LSD, Big Dog®, Polished	\$1,000.00
SC02009BR	For LSD, Big Dog®, Brushed	\$1,000.00



Stainless Creations Top Fuel Exhaust

- Separate baffles available — see info on next page

SCETFR	For RSD, Evolution®	\$700.00
SCETFL	For LSD, Evolution®	\$700.00
SCETFTC	For LSD, TC	\$700.00

ADD S For Brushed

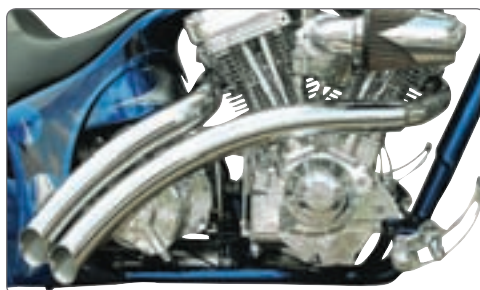

Stainless Creations Octane Exhaust

- Separate baffles available — see info on next page

SCETR	For RSD, Evolution®	\$700.00
SCETL	For LSD, Evolution®	\$700.00
SCETTC	For LSD, TC	\$700.00

ADD S For Brushed



Stainless Creations C4L Exhaust

- Separate baffles available — see info on next page

SCEC4LR	For RSD, Evolution®	\$700.00
SCEC4LL	For LSD, Evolution®	\$700.00
SCEC4LTC	For LSD, TC	\$700.00

ADD S For Brushed

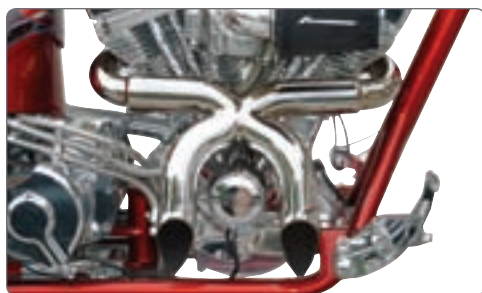

Stainless Creations Disorder Exhaust

• Separate baffles available — see info below

SCEDLR	For RSD/LSD, Evolution®	\$1,125.00
SCEDLTC	For LSD, TC	\$1,125.00

ADD S For Brushed



Stainless Creations Pandemonium Exhaust

• Separate baffles available — see info below

SCEPR	For RSD, Evolution®	\$1,125.00
SCEPL	For LSD, Evolution®	\$1,125.00

ADD S For Brushed



Stainless Creations Mayhem Exhaust

• Separate baffles available — see info below

SCEMR	For RSD, Evolution®	\$1,125.00
SCEML	For LSD, Evolution®	\$1,125.00

ADD S For Brushed



Stainless Creations Eliminator Exhaust

• Separate baffles available — see info below

SCEELR	For RSD, Evolution®	\$800.00
SCEELL	For LSD, Evolution®	\$800.00
SCEELTC	For LSD, TC	\$800.00

ADD S For Brushed



Stainless Creations Chaos II Exhaust

• Separate baffles available — see info below

SCEC2R	For RSD, Evolution®	\$775.00
SCEC2L	For LSD, Evolution®	\$775.00

ADD S For Brushed



Stainless Creations Chaos III Exhaust

• Separate baffles available — see info below

SCEC3R	For RSD, Evolution®	\$775.00
SCEC3L	For LSD, Evolution®	\$775.00

ADD S For Brushed

B. Stainless Creations Baffles (Not Shown)

Save some time and trouble with your neighbors and the police!
 Please specify exhaust style when ordering.

SCETBP	Performance Baffles	\$80.00
SCETBQ	DB Reducing Performance Baffles	\$80.00

C. Stainless Creations Offset Spacer Kits

• For perfect fitment of Stainless Creations pipes

SCSKL2	LSD, 1/2" Offset	\$29.99
SCSKL3	LSD, 1" Offset	\$29.99
SCSKL5	LSD, 1 1/4" Offset	\$29.99
SCSKL4	LSD, 1 1/2" Offset	\$29.99
SCSKBDL	LSD, Big Dog®	\$29.99
SCSKBDR	RSD, Big Dog®	\$29.99
SCSKR1	RSD, 1/2" Offset	\$29.99
SCSKR2	RSD, 3/4" Offset	\$29.99



Stainless Creations Outlaws Exhaust

• Separate baffles available — see info at left

SCELR	For RSD, Evolution®	\$775.00
SCELR2L	For LSD, Evolution®	\$775.00

ADD S For Brushed



Stainless Creations Hellstrom Exhaust

• Separate baffles available — see info at left

SCEHSR	For RSD, Evolution®	\$1,200.00
SCEHSL	For LSD, Evolution®	\$1,200.00

ADD S For Brushed



B. C. Detroit Bros.® Digger & Dumper Exhaust Pipes

• Rear mount on lower rear pipes, fit all '71-'84 FX, FXWG, FLHS and late-style shovelhead engines or the new S&S® SH models with a tab on the back for an additional mounting spot.

• Dumpers for Evolution® fit all '86-'05 Softail®

• **Please note the make, model and engine of bike when ordering**

DBEP001E	Digger For Evolution®	\$549.99
DBEP001S	Digger For Shovelhead	\$549.99
DBEP002E	Dumper For Evolution®	\$499.99
DBEP002S	Dumper For Shovelhead	\$499.99
DBMS002	Exhaust Cuff (Sold Separately)	\$119.99

ENGINE
 FUEL SYSTEMS
 EXHAUST
 ELECTRICAL
 DRIVETRAIN
 WHEELS
 SUSPENSION
 SHEETMETAL
 FRAMES
 CONTROLS
 LIGHTING
 BAGGERS
 TOOLS
 APPAREL



- Stepped, internal head pipe design incorporates Hooker's nearly four decades of race technology for top-end horsepower without sacrificing low-end torque
- 2.5" with no visible bluing or seams
- Included muffler cartridge gives a deep, throaty note with sacrificing performance — quieter and louder cartridges available

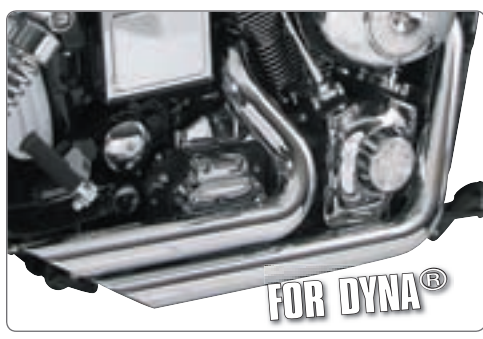
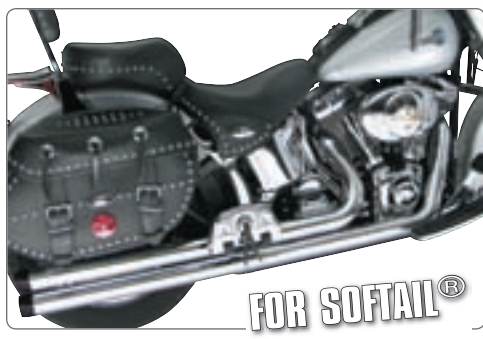

For Softail®		MSRP
HK279421D	'84-'06 w/ 96"+, 49-State, Short Stag. Straight Cut, Darksides™	\$632.66
HK279423D	'84-'06 w/ 96"+, 49-State, Short Staggered Slash Cut, Darksides™	\$632.66
HK279413	'84-'06 w/ 96"+, 49-State, Mid Staggered, Slash Cut, Chrome	\$581.63
HK279401	'84-'06 w/ 96"+, 49-State, Long Even Straight Cut, Chrome	\$581.63
HK279023BWR	Baker Drivetrain® 300 Wide Tire Conversion, Chrome	\$624.53
HK279041	'84-'06 w/ 96"+, Short Staggered, Straight Cut, Chrome	\$584.94
HK279043	'84-'06 w/ 96"+, Short Staggered, Slash Cut, Chrome	\$584.94
HK279021	'84-'06 w/ 96"+, Mid Staggered, Straight Cut, Chrome	\$584.94
HK279023	'84-'06 w/ 96"+, Mid Staggered, Slash Cut, Chrome	\$584.94
HK279022	'84-'06 w/ 96"+, Mid Staggered, Side Slash Cut, Chrome	\$584.94
HK279031	'84-'06 w/ 96"+, Mid Even, Straight Cut, Chrome	\$584.94
HK279032	'84-'06 w/ 96"+, Mid Even, Side Slash Cut, Chrome	\$284.94
HK279011	'84-'06 w/ 96"+, Long Staggered, Straight Cut, Chrome	\$584.94
HK279013	'84-'06 w/ 96"+, Long Staggered, Slash Cut, Chrome	\$584.94
HK279012	'84-'06 w/ 96"+, Long Staggered, Side Slash Cut, Chrome	\$584.94
HK279001	'84-'06 w/ 96"+, Long Even Straight Cut, Chrome	\$584.94
HK279002	'84-'06 w/ 96"+, Long Even Side Slash Cut, Chrome	\$584.94
HK279091	'84-'06 w/ 80"+, Short Staggered, Straight Cut, Chrome	\$584.94
HK279093	'84-'06 w/ 80"+, Short Staggered, Slash Cut, Chrome	\$584.94
HK279091D	'84-'06 w/ 80"+, Short Staggered Straight Cut, Darksides™	\$683.37
HK279043D	'84-'06 w/ 80"+, Short Staggered Slash Cut, Darksides™	\$683.37
HK279093D	'84-'06 w/ 80"+, Short Staggered Slash Cut, Darksides™	\$683.37
HK279071	'84-'06 w/ 80"+, Mid Staggered, Straight Cut, Chrome	\$584.94
HK279073	'84-'06 w/ 80"+, Mid Staggered, Slash Cut, Chrome	\$584.94
HK279072	'84-'06 w/ 80"+, Mid Staggered, Side Slash Cut, Chrome	\$584.94
HK279081	'84-'06 w/ 80"+, Mid Even, Straight Cut, Chrome	\$584.94
HK279082	'84-'06 w/ 80"+, Mid Even, Side Slash Cut, Chrome	\$584.94
HK279061	'84-'06 w/ 80"+, Long Staggered, Straight Cut, Chrome	\$584.94
HK279063	'84-'06 w/ 80"+, Long Staggered, Slash Cut, Chrome	\$584.94
HK279062	'84-'06 w/ 80"+, Long Staggered, Side Slash Cut, Chrome	\$584.94
HK279051	'84-'06 w/ 80"+, Long Even, Straight Cut, Chrome	\$284.94
HK279052	'84-'06 w/ 80"+, Long Even, Side Slash Cut, Chrome	\$584.94
For Sportster®		
HK279441	'04-Later XL, 49-State, Long Even Straight Cut, Chrome	\$581.63
HK279463	'04-Later XL, 49-State, Mid Staggered Slash Cut, Chrome	\$581.63
HK279463D	'04-Later XL, 49-State, Mid Staggered Slash Cut, Darksides™	\$581.63
HK279452	'04-Later XL, 49-State, Mid Even Side Slash Cut, Chrome	\$581.63
HK279291	'04-'06 XL, Long Even Straight Cut, Chrome	\$568.09
HK279292	'04-'06 XL, Long Even Side Slash Cut, Chrome	\$568.09
HK279301	'04-'06 XL, Mid Staggered Straight Cut, Chrome	\$568.09
HK279302	'04-'06 XL, Mid Staggered Side Slash Cut, Chrome	\$568.09
HK279303	'04-'06 XL, Mid Staggered Slash Cut, Chrome	\$568.09
HK279311	'04-'06 XL, Mid Even Straight Cut, Chrome	\$568.09
HK279312	'04-'06 XL, Mid Even Side Slash Cut, Chrome	\$568.09
HK279321	'04-'06 XL, Long Staggered Straight Cut, Chrome	\$568.09

For '87-Later Dyna®		MSRP
HK279151	80"+, Long Even, Straight Cut, Chrome	\$567.86
HK279152	96"+, Long Even, Side Slash Cut, Chrome	\$567.86
HK279161	96"+, Long Staggered, Straight Cut, Chrome	\$567.86
HK279162	96"+, Long Staggered, Side Slash Cut, Chrome	\$567.86
HK279163	96"+, Long Staggered, Slash Cut, Chrome	\$567.86
HK279171	96"+, Mid Staggered, Straight Cut, Chrome	\$567.86
HK279172	96"+, Mid Staggered, Side Slash, Chrome	\$567.86
HK279173	96"+, Mid Staggered, Slash Cut, Chrome	\$567.86
HK279181	96"+, Mid Even, Straight Cut, Chrome	\$567.86
HK279182	96"+, Mid Even Slash Cut, Chrome	\$567.86
HK279191	96"+, Short Staggered, Straight Cut, Chrome	\$567.86
HK279193	96"+, Short Staggered, Slash Cut, Chrome	\$567.86
HK279201	80"+, Long Even, Straight Cut, Chrome	\$567.86
HK279202	80"+, Long Even, Side Slash Cut, Chrome	\$567.86
HK279211	80"+, Long Staggered, Straight Cut, Chrome	\$567.86
HK279212	80"+, Long Staggered, Side Slash Cut, Chrome	\$567.86
HK279213	80"+, Long Staggered, Slash Cut, Chrome	\$567.86
HK279221	80"+, Mid Staggered, Straight Cut, Chrome	\$567.86
HK279222	80"+, Mid Staggered, Side Slash Cut, Chrome	\$567.86
HK279223	80"+, Mid Staggered, Slash Cut, Chrome	\$567.86
HK279231	80"+, Mid Even, Straight Cut, Chrome	\$567.86
HK279232	80"+, Mid Even, Side Slash Cut, Chrome	\$567.86
HK279241	80"+, Short Staggered, Straight Cut, Chrome	\$567.86
HK279243	80"+, Short Staggered, Slash Cut, Chrome	\$567.86

For Big Dog®		MSRP
HK279023SWR	250mm Chopper/Mastiff, , Chrome	\$624.53
HK279023HWR	300mm Ridgeback/Pitbull, , Chrome	\$624.53

For Dressers		MSRP
HK279431	'85-Later , 49-State, 2.5", Long Even, Straight Cut, Chrome	\$581.63
HK279431D	'85-Later , 49-State, 2.5", Long Even, Straight Cut, Darksides™	\$642.85
HK279432	'85-Later , 49-State, 2.5", Long Even, Side Slash Cut, Chrome	\$581.63
HK279473	'85-Later , 49-State, 2.5", Long Staggered, Slash Cut, Chrome	\$581.63
HK279271	'84-'06 w/ 80"+, 2.5", Long Even, Straight Cut, Chrome	\$570.57
HK279272	'84-'06 w/ 80"+, 2.5", Long Even, Side Slash Cut, Chrome	\$570.57
HK279281	'84-'06 w/ 80"+, 2.5", Long Staggered, Straight Cut, Chrome	\$570.57
HK279282	'84-'06 w/ 80"+, 2.5", Long Staggered, Side Slash Cut, Chrome	\$570.57
HK279283	'84-'06 w/ 80"+, 2.5", Long Staggered, Slash Cut, Chrome	\$570.57
HK279251	'84-'06 w/ 96"+, 2.5", Long Even, Straight Cut, Chrome	\$284.94
HK279252	'84-'06 w/ 96"+, 2.5", Long Even, Side Slash Cut, Chrome	\$570.57
HK279261	'84-'06 w/ 96"+, 2.5", Long Staggered, Straight Cut, Chrome	\$570.57
HK279262	'84-'06 w/ 96"+, 2.5", Long Staggered, Side Slash Cut, Chrome	\$570.57
HK279263	'84-'06 w/ 96"+, 2.5", Long Staggered, Slash Cut, Chrome	\$570.57

HK27272B	Billet Tips, Black	\$153.77
HK272721S	Billet Tips, Silver	\$153.77
HK272722C	Billet Tips, Chrome	\$153.77



Hooker® FourBidden™ Exhaust

- Dyno testing of the FourBidden™ added 13 HP to a very mildly tuned '05 Softail!
- Four 1 3/8" primary tubes merge into one 3" collector for awesome styling and aggressive sound (removable baffle included).
- Features a 3" two-way adjustable tip engraved with the Hooker® logo

PART	DESCRIPTION	MSRP
For '84-'06 Softail®:		
HK279083D	Side/Down Slash, Darkside™	\$762.33
HK279083	Side/Down Slash, Chrome	\$758.80
HK279085D	Turn Down/Out, Darkside™	\$762.33
HK279085	Turn Down/Out, Chrome	\$758.80
HK279086	Side/Down Slash, Metallic Ceramic	\$755.27
HK279087	Turn Down/Out, Metallic Ceramic	\$755.27

For Carbureted Big Dog® Models:		
HK279053	300mm Big Dog®, Slash-Cut Ends, Chrome	\$806.53
HK279053D	300mm Big Dog®, Slash-Cut Ends, Black Ceramic	\$826.52
HK279053	300mm Big Dog®, Slash-Cut Ends, Chr. w/ Int. Ceramic	\$826.52
HK279055	300mm Big Dog®, Turn Ends, Chrome	\$806.53
HK279055D	300mm Big Dog®, Turn Ends, Black Ceramic	\$826.52
HK279057	300mm Big Dog®, Turn Ends, Chrome w/ Int. Ceramic	\$826.52
HK279103	250mm RSD Big Dog®, Slash-Cut Ends, Chrome	\$806.53
HK279103D	250mm RSD Big Dog®, Slash-Cut Ends, Black Ceramic	\$826.52
HK279106	250mm RSD Big Dog®, Slash-Cut Ends, Chr. w/ Int. Cer.	\$826.52
HK279105	250mm RSD Big Dog®, Turn Ends, Chrome	\$806.53
HK279105D	250mm RSD Big Dog®, Turn Ends, Black Ceramic	\$826.52
HK279107	250mm RSD Big Dog®, Turn Ends, Chrome w/ Int. Cer.	\$826.52

Hooker® Troublemaker™ Exhaust



- Stepped head pipe design with no visible bluing
- Top-end horsepower without sacrificing low-end torque
- A metallic ceramic coating on the internal head pipes retains the right amount of heat, increasing the exhaust velocity for



- more horsepower
- Includes a muffler cartridge that delivers a deep rumble
- Optional muffler cartridges are also available offering either a smooth mellow sound or loud sound with improved flow



- Includes exhaust gaskets, c-clips, chromed flanges, machined brackets, nuts, bolts and detailed instructions.

For Sportster®:

	MSRP
HK274113	'04-Later 49-State (Fwd Ctrl Only), 2.5" Radius w/ Slash, Chrome \$602.04
HK274114	'04-Later 49-State (Fwd Ctrl Only), 2.5" Radius w/ Scallop, Chrome \$602.04
HK274114D	'04-Later 49-State (Fwd Ctrl Only), 2.5" Radius w/ Scallop, Darkside™ \$632.66
HK274041	'04-'06 (Excludes Mid Ctrl), 2.5" Radius w/ Straight Cut Ends, Chrome \$613.29
HK274043	'04-'06 (Excludes Mid Ctrl), 2.5" Radius w/ Slash Cut Ends, Chrome \$613.29
HK274044	'04-'06 (Excludes Mid Ctrl), 2.5" Radius w/ Scallop Cut Ends, Chrome \$613.29

For Big Dog®:

	MSRP
HK274053	Ridgeback™/Pitbull™, Slash Cut, Chrome \$662.27
HK274053D	Ridgeback™/Pitbull™, Slash Cut, Darkside™ \$836.42
HK274054	Ridgeback™/Pitbull™, Scallop Cut, Chrome \$662.27
HK274054D	Ridgeback™/Pitbull™, Scallop Cut, Darkside™ \$836.50
HK274063	300mm Ridgeback™/Mastiff™, Slash Cut, Chrome \$662.27
HK274063D	300mm Ridgeback™/Mastiff™, Slash Cut, Darkside™ \$836.42
HK274064	300mm Ridgeback™/Mastiff™, Scallop Cut, Chrome \$662.27
HK274064D	300mm Ridgeback™/Mastiff™, Scallop Cut, Darkside™ \$836.42
HK274073	300mm K9/Mastiff™, Slash Cut, Chrome \$662.27
HK274073D	300mm K9/Mastiff™, Slash Cut, Darkside™ \$836.42
HK274074	300mm K9/Mastiff™, Scallop Cut, Chrome \$662.27
HK274074D	300mm K9/Mastiff™, Scallop Cut, Darkside™ \$836.42

For Softail®:

	MSRP
HK274104	'84-Later w/ 96"+, 49-State, 2.5" Radius w/ Scallop Cut, Chrome \$621.96
HK274104D	'84-Later w/ 96"+, 49-State, 2.5" Radius w/ Scallop Cut, Darkside™ \$709.16
HK274103	'84-Later w/ 96"+, 49-State, 2.5" Radius w/ Slash Cut, Chrome \$602.04
HK274103D	'84-Later w/ 96"+, 49-State, 2.5" Radius w/ Slash Cut, Darkside™ \$632.66
HK274004	'84-'06 w/ 96"+, 2.5" Radius w/ Scallop Cut Ends, Chrome \$621.96
HK274003	'84-'06 w/ 96"+, 2.5" Radius w/ Slash Cut Ends, Chrome \$621.96
HK274001	'84-'06 w/ 96"+, 2.5" Radius w/ Straight Cut Ends, Chrome \$621.96
HK274004D	'84-'06 w/ 96"+, Scallop Cut, Darkside™ \$709.16
HK274003D	'84-'06 w/ 96"+, Slash Cut, Darkside™ \$709.16
HK274001D	'84-'06 w/ 96"+, Straight Cut, Darkside™ \$709.16
HK274014	'84-'06 w/ 80"+, 2.5" Radius w/ Scallop Cut Ends, Chrome \$621.96
HK274013	'84-'06 w/ 80"+, 2.5" Radius w/ Slash Cut Ends, Chrome \$621.96
HK274011	'84-'06 w/ 80"+, 2.5" Radius w/ Straight Cut Ends, Chrome \$621.96
HK274014D	'84-'06 w/ 80"+, Scallop Cut, Darkside™ \$709.16
HK274013D	'84-'06 w/ 80"+, Slash Cut, Darkside™ \$709.16
HK274011D	'84-'06 w/ 80"+, Straight Cut, Darkside™ \$621.96

For '91-'05 Dyna®:

	MSRP
HK274081	80"+, 2.5" Radius w/ Straight Cut Ends, Chrome \$621.96
HK274083	80"+, 2.5" Radius w/ Slash Cut Ends, Chrome \$621.96
HK274084	80"+, 2.5" Radius w/ Scallop Cut Ends, Chrome \$621.96
HK274091	96"+, 2.5" Radius w/ Straight Cut Ends, Chrome \$621.96
HK274093	96"+, 2.5" Radius w/ Slash Cut Ends, Chrome \$621.96
HK274094	96"+, 2.5" Radius w/ Scallop Cut Ends, Chrome \$621.96

ENGINE
 FUEL SYSTEMS
 EXHAUST
 ELECTRICAL
 DRIVETRAIN
 WHEELS
 SUSPENSION
 SHEETMETAL
 FRAMES
 CONTROLS
 LIGHTING
 BAGGERS
 TOOLS
 APPAREL

A. Force Motor Products Zoomie Exhaust For BT

- Short, sweet and wicked — stepped for maximum performance
- Couple with a Forcewinder intake for a complete performance package
- Black color is a black jet hot coat finish

PART	DESCRIPTION	MSRP	PART	DESCRIPTION	MSRP
F7084100	Chrome	\$415.95	F7084200	Black	\$415.95

B. Force Motor Products Bullet Mufflers For V-Rod®

- Sound "oh so nice," and add HP with their free flowing design
- Easy to install — in less than a half hour
- Black color is a black jet hot coat finish

PART	DESCRIPTION	MSRP
F7086100	Short, Chrome	\$533.99
F7086100B	Short, Black	\$533.99
F7087100	Long, Chrome	\$533.99
F7087100B	Long, Black	\$533.99
F7088100	Staggered, Chrome	\$533.99
F7088100B	Staggered, Black	\$533.99

C. Force Motor Products 38's Mufflers For V-Rod®

- Adds horsepower and gives a VRSC the sound and respect it deserves
- Retains the stock headpipes for efficient and necessary scavenging
- Race tuner kit and high-flow filter recommended to recalibrate air/fuel ratio

PART	DESCRIPTION	MSRP
F7082500	Long, Chrome	\$460.05
F7082500B	Long, Black	\$460.05
F7080500	Staggered, Chrome	\$460.05
F7080500B	Staggered, Black	\$460.05
F7081500	Short, Chrome	\$460.05
F7081500B	Short, Black	\$460.05

D. Bulletprüf™ Universal Exhaust Flanges & Gaskets

PART	DESCRIPTION	MSRP
BPE301	Flange Kit w/ Clip Ring For Evolution®/Twin Cam, Chrome	\$29.99
BPE305	Flange Kit w/ Flat Gasket For Evolution®/Twin Cam, Chrome	\$32.99
BPE308	Flange Kit w/ Tapered Gasket For Evolution®/Twin Cam, Chrome	\$35.99

E. Hooker® Exhaust Accessories

PART	DESCRIPTION	MSRP
HK27249	Flange Gaskets For Evolution®/Twin Cam	\$12.29
HK27250	Flange Kit, Chrome Flanges & C-Clips For Evolution®/TC	\$31.43
HK27393	Step Tuned® Muffler Cartridge, 1.875", Mellow Tone	\$78.63

F. Crime Scene Choppers Astro Tips Exhaust Tip

- Precision investment cast in 17-4 stainless steel and hand polished
- Fits a 2" OD pipe, 2 5/8" OD, 4" overall length

PART	DESCRIPTION	MSRP
CSC802	Astro Tips, 2" Pipes, Single	\$89.00

G. Crime Scene Choppers Mordor Exhaust Tip

- For 1.75" exhaust pipes
- Hand made, triple chrome plated, includes stainless steel mount screw

PART	DESCRIPTION	MSRP
CSC806	Mordor Tips, 1.75" Pipes, Single	\$89.99

H. Crime Scene Choppers Weld-On Step Adapters

- Weld-on step adapters for building custom exhaust pipes

PART	DESCRIPTION	MSRP
CSC708	Adapter For Building 1.75" To 2" Exhaust, Mild Steel	\$19.00
CSC709	Adapter For Building 2" To 2.25" Exhaust, Mild Steel	\$19.00
CSC710	Adapter For Building 1.75" To 2.25" Exhaust, Mild Steel	\$19.00

I. Blue • Job®, The World's Best Chrome Polish

- Uses chemical and mechanical action to lift bluing, thumbprints, rust and rubber
- The most effective cleaning agent we've found for chrome or stainless pipes
- Use before burn-in to help prevent bluing and marks

PART	DESCRIPTION	MSRP
BJCP12	12-Pack	\$134.40
BJCPW	Blue•Job™ Polish Wipes, 36-Pack	\$142.20

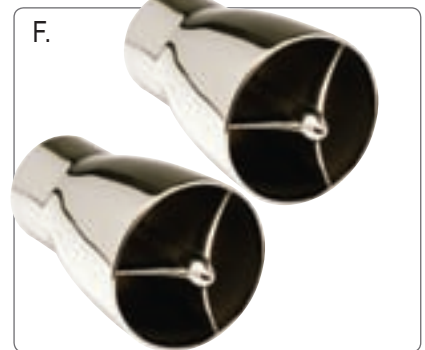
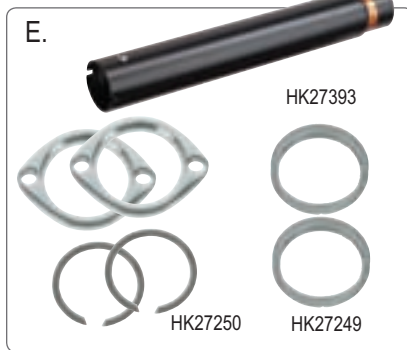

A.
**Bolt-On
 Easy To Use
 Triple Spark**



**ACCULIGHT
 IGNITION SYSTEM**

A. Spyke® Acculight Ignition System

- The only triple-fire ignition on the market—which means that it can fire up to three times per compression stroke. Burn fuel more completely!
- High-tech, yet easy to install in single- or dual-fire mode
- Uses optical sensors for up to three stable and precisely timed sparks per stroke
- Preset with four fully changeable curves
- Coil saturation can be set to different values at different RPM's
- Two separate RPM activated switches with variable on/off RPM settings can have different values for all sensor states—use with nitrous or auto-shifting
- Tachometer output to almost any tachometer, including automotive tachometers
- Automatic coil shutoff
- Precision stainless steel rotor
- Special curves available for racers, engine builders and OEM's — call for details

PART	DESCRIPTION	MSRP
SPIASA	3-Spark, Single-Fire Ignition	\$273.00
SPIASAK	Single-Fire Ignition w/ Single-Fire Coil & Plug Wires	\$385.00
SPIADA	3-Spark, Dual-Fire Ignition	\$227.50
SPIADAK	Dual-Fire Ignition w/ Dual-Fire Coil & Plug Wires	\$305.49

Included With AIS

B. Stampede™ Optically-Triggered Ignitions

- Extremely efficient vs. Hall Effect ignitions that can be off as much as 14°
- Fires a very stable spark across multiple sparks with two sparks per compression stroke on a 30° spread
- Advance curve/rev and a static timing light which requires no external timing light
- Automatic coil shutoff to help save batteries and coils
- Built-in tach correction is included at no extra charge
- V.O.E.S. compatible for heavy bikes and high-compression engines
- Kits include ignition, 80,000 volt/3 ohm Spyke® coil and Taylor® plug wires

PART	DESCRIPTION	MSRP
SPDFMS	Dual-Fire Ignition	\$169.99
SPDFMSK	Dual-Fire Ignition Kit w/ Dual-Fire Coil & Plug Wires	\$199.99
SPIGS	Single/Dual-Fire Ignition	\$236.00
SPIGSK	Single/Dual-Fire Ignition, Single-Fire Coil & Plug Wires	\$319.99

C. Compu-Fire® Mechanical Advance Ignitions

- Convert points type ignitions to electronic ignitions in '70-Later BT and XL
- Can also replace the Prestolite-type modules and H-D® electronic advance modules with the addition of an OE style mechanical advancer
- Use single-fire with red rotor twins (included)
- Use dual-fire with blue rotor twins (included)

PART	DESCRIPTION	MSRP
CF20200	Single-Fire Ignition For '70-Later BT	\$132.11
CF20100	Dual-Fire Ignition For '70-Later BT	\$102.26
CF51105	Tach Adapter For Single Fire Coils	\$37.55

D. Compu-Fire® Electronic Advance Performance Ignitions

- For '70-Later Big Twins & XL, excluding Twin Cam
- The most user friendly ignitions on the market with a range of advance curves
- Easy installation is made possible with a built-in LED static timing light

PART	DESCRIPTION	MSRP
CF21835	High-Comp w/ Elec. Start, Select. Advance, Street Use	\$257.16
CF21835KS	High-Comp w/ Kick Start, Select. Advance, Street Use	\$257.16
CF21860	Super Sport Race w/ Selectable Retard	\$257.16
CF51105	Tach Adapter For Single Fire Coils	\$37.55
CF50108	Replacement Rotor For Electronic Advance Ignition	\$15.61

E. S&S Cycle® Super Stock® Ignition Module & Install Kits For S&S® Engines

- Now available to work with kickstart
- Includes rotor, VOES switch and hardware

Modules Only For:	MSRP	Modules & Kits For:	MSRP
SS551340 Module For S&S® SH80	\$154.95	SS551350 For S&S® SH80	\$219.95
SS551341 Module For S&S® SH93	\$154.95	SS551351 For S&S® SH93	\$219.95
SS551342 Module For S&S® SH93HC	\$154.95	SS551352 For S&S® SH93HC	\$219.95
SS551343 Module For S&S® SH103	\$154.95	SS551353 For S&S® SH103	\$219.95
SS551344 Module For S&S® V96	\$154.95	SS551354 For S&S® V96	\$219.95
SS551345 Module For S&S® V113	\$154.95	SS551355 For S&S® V113	\$219.95
SS551346 Module For S&S® V124	\$154.95	SS551356 For S&S® V124	\$219.95

Kits Available w/ Coil & Plug Wires

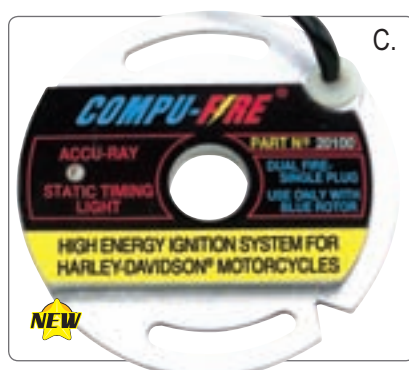

ENGINE
 FUEL SYSTEMS
 EXHAUST
 ELECTRICAL
 DRIVETRAIN
 WHEELS
 SUSPENSION
 SHEETMETAL
 FRAMES
 CONTROLS
 LIGHTING
 BAGGERS
 TOOLS
 APPAREL

A. Crane Cams® HI-4 Ignitions

- High performance replacement for the factory ignition
- Fits in the nose cone with no inconvenient external module
- Adjustable advance curves and rev limiter allow fine tuning for race or street
- Static timing LED allows easy installation with no guesswork
- For '70-'98 Evolution® & '71-Later XL, Excludes XL1200S unless noted

PART	DESCRIPTION	MSRP
CR81100	HI-4 Dual Fire Ignition	\$257.75
CR82100	HI-4 Single-Fire Street/Race Ignition	\$287.92
CR82200	HI-4 Single-Fire 50-State Street/Race Ignition	\$287.92
CR83100	HI-4E For '84-'99 Evolution® w/ 7-Pin Connector	\$336.09
CR83101	HI-4E For '84-'99 Evolution® w/ 8-Pin Connector	\$336.09
HI-4E Ignitions w/ Coil & Spark Plug Wires:		
CR84100	High-Output Kit For '70-'84 BT	\$469.58
CR84101	Kit For '84-'94 BT w/ 7-Pin Connector, Excl. FLT	\$523.19
CR84102	Kit For '95-Later BT & '94-Later XL w/ 8-Pin Connector	\$523.19



B. Crane Cams® HI-2 & HI-1 Ignitions

High energy system replacement for '70-'99 OE point and condenser type ignitions.

PART	DESCRIPTION	MSRP
CR81000	HI-1 Dual-Fire Inductive Ignition	\$196.78
CR82000	HI-2 Single Fire Inductive Ignition	\$270.58



C. Dyna® 2000i In-Cone Ignitions

- Many of the same features of the best selling Dyna® 2000 module with a completely new design that fits under the cam cover.
- Contact your MC Advantages for a full listing of features for this ignition
- Programmable features and data recovery require programming kits below
- For '70-'98 Carbureted Big Twins

PART	DESCRIPTION	MSRP
DCS2KC1P	Module Only	\$249.00
DCS2KC2P	Single-Fire Module & (2) DC31 Coils	\$399.99
DCS2KC3P	Dual-Plug/Single-Fire Kit	\$399.99
DCS2KC4P	Dual-Plug/Dual-Fire & (2) DC21 Coils	\$399.99
DCS2KC5P	Single-Plug/Single-Fire & DC65 Twin Fire Mini Coil	\$399.99

Programming Kits For:

DCSPK1	D2Ki-P and All D2Ki Kits w/Coils	\$99.99
DCSPK2	2000HD1EP, 2000HD2EP and SFK-1	\$99.99
DCSPK3	2000HD1E8, 2000HD2E8 and SFK-3	\$99.99
DCSPK4	For Twin Cam 88®-2P	\$99.99



D. Dyna® S Ignitions w/ Coil (Street Use)

- Self-contained electronic ignition system with the latest state-of-the-art engineering with the reliability of use by top racers over twenty years
- Completely housed behind the ignition cover and uses a magnetic rotor with the original spark advancer, effectively maintaining the factory advance curve

PART	DESCRIPTION	MSRP
DCS61	'70-'99 (Dual-Fire) Use w/ Points Coil	\$124.99
DCS62	'70-'99 (Single-Fire) Use w/ Points Coils	\$149.99
DCSK61	'70-'99 (Dual-Fire) w/ Dyna® Dual-Fire Coil	\$189.99
DCSK62	'70-'99 (Single-Fire) w/ Dyna® Single-Fire Coil	\$279.99



E. Daytona Twin Tec Ignitions For '70-'99 BT

- Two advance curve groups with adjustable advance for stock to mod engines
- Digitally set RPM limit (100 RPM steps)
- Selectable single or dual fire mode
- Selectable multi-spark mode for quick starting and smooth cruise
- Coil outputs protected against short circuits
- Ask for USB interface #DAUSBINTF to program custom advance curves
- Billet aluminum housing

PART	DESCRIPTION	MSRP
DA1005	Model 1005 For '70-'99 BT & '71-'97 XL, Internal	\$269.99
DA1005S	Model 1005S For '98-'02 XL (Excludes 1200S), Internal	\$289.99
DA1006	Model 1006 For 7-Pin '90-'94 BT & '90-'93 XL, External	\$289.99
DA1007	Model 1007 For 8-Pin '95-'98 BT & '94-'97 XL, External	\$289.99
DA3005	Model 1005 Ignition, Coil & Plug Wire Kit	\$359.99
DA3005S	Model 1005S Ignition, Coil & Plug Wire Kit	\$379.99
DA3006	Model 1006 Ignition, Coil & Plug Wire Kit	\$379.99
DA3007	Model 1007 Ignition, Coil & Plug Wire Kit	\$379.99

F. S&S Cycle® IST Ignition System

- Simple install, auto timing adjustment, single-fire operation and auto dwell-adjust

PART	DESCRIPTION	MSRP
SS551221	Ignition Module	\$384.95
Installation Kits For:		
SS551049	'84-'99 Carb BT & '86-'03 XL	\$654.95
SS551012	'99-'03 Twin Cam 88®	\$174.95
SS551220	'04-'06 Carb Twin Cam 88®	\$189.95
SS551225	'04-'05 Sportster®	\$199.95
SS551050	S&S® 4 1/8" Bore '84-'99 BT	\$294.95





A.

A. Dyna® 2000 Digital Ignitions

- The market standard — replaces stock non-adjustable ignitions
- Expanded advance curve functionality with the option to use vacuum advance compensation via a V.O.E.S. switch and a special retard mode for use with turbocharged and nitrous bikes
- Select from eight advance curves with quick curve to simulate a mechanical advancer for hot rod motors
- Four rev limiter settings and retard of 5°, 7°, or 10° upon activation of input
- Uses the stock factory pick-up — harness is available for installing pre '91 bikes
- Requires programming kit, contact MC Advantages for details

PART	DESCRIPTION	MSRP
DCSD2H1EP	Single/Dual-Fire	\$249.99
DCSD2H1E8P	Single/Dual-Fire 8-Pin	\$249.99
DCS1009002	7 to 8-Pin Adapter	\$69.99
DCSD2H2EP	Dual-Fire	\$199.99
DCSD2H2E8P	Dual-Fire 8-Pin	\$199.99
DCS1009001	Extension Harness	\$39.00



For '99-'03 Carbureted TC

B.

B. Crane Cams® FireBall HI-4TC Carbureted Ignitions

- The same performance and absolute reliability of FireBall HI-4 and FireBall HI-4E, the worlds favorite!
- Easy to install — mounts in place of the stock module with plug-in installation
- True Single-Fire — Crankshaft position sensor is used to establish accurate firing — rear cylinder timing can be offset from -5 to +4. Initial timing is set from -5 to +4, both via easily adjusted, rotary switch
- Ten advance curve families for stock to wild! — easily selected via rotary switch
- Programmable advance curves for programming on or off the bike!

PART	DESCRIPTION	MSRP
CR83170	FireBall® Performance Ignition For '99-'03 TC88®	\$370.18
CR83180	FireBall® HI-4TC Performance Ignition For '04-Later TC88® & '03-Later XL w/ 12-Pin Plug	\$370.18
CR83220	HI-4TC Interface Cable & Software For CR83180	\$163.84
CR83210	HI-4TC Programming Software Cables & Power Adapter For CR83170	\$163.84



C.

C. Daytona Twin Tec Ignitions For Twin Cam

- Wide timing advance adjustment range for stock to highly modified engines
- Digitally set RPM limit (100 RPM steps)
- Selectable multi-spark mode for quick starting and smooth cruise
- Coil outputs protected against short circuits
- Optional USB interface and software for programming custom advance curve
- Billet aluminum housing with black anodized finish
- Easy plug-in installation
- Supports all sensors including theft/security module
- USB Interface includes all required adapters for DA1005-1007, DATC88, DATC88A and TCFI/VRFI fuel injection systems

PART	DESCRIPTION	MSRP
DATC88	Plug-In Ignition For Carbureted '99-'03 TC	\$289.00
DATC88A	Plug-In Ignition For 12-Pin Carbureted '03-'06 TC/XL	\$289.00
DA3008	DATC88 Ignition, Coil & Wires Kit	\$379.00
DA3088	DATC88A Ignition, Coil & Wires Kit	\$439.00
DATC88ADAPT	TC88 Power Adapter	\$99.95
DATC88AADAPT	TC88A Power Adapter	\$99.95
DAUSBINTF	USB Interface	\$99.95



D.

D. Dyna® 2000 Standard Ignitions For Twin Cam

- Single fire, fully programmable ignition with a one-year warranty
- 16 pre-programmed advance curves, in 3 groups from stock/slightly modified to heavily and insanely modified motors
- 8 rev. limiter settings, (5750-7250) in 250 RPM steps
- All functions full digital accuracy
- Coil compatibility from stock to performance (less than 1 ohm resistance)
- Coil current constantly monitored to provide constant full spark energy
- Use of all stock sensors, mounts and connectors
- Reverse battery and spike protection are built-in

*Dyna 2000 Ignition's Programmable Features & Data Recovery features require programming kits. Refer to HD programming kits

PART	DESCRIPTION	MSRP
DCSTC882P	For '99-'03 TC w/ Carb	\$249.99
DCSTC883	For '04-'06 TC w/ Carb	\$249.99
DCSPT1	For '04-'06 Sportster®	\$249.99

E. Dyna® 4000 Ignitions (Not Shown)

- Specifically designed to meet the needs of the serious racer
- Significantly increases spark energy and also includes built in launch and over-rev RPM limiters
- Uses microprocessors to provide extremely accurate control over the entire ignition process to maximize spark energy and control rev limiting with more precision than had previously been available

	MSRP	PART	DESCRIPTION	MSRP	
DCSPK4H1DF	Single-Plug/Dual-Fire Kit	\$499.99	DCSP4H1S	Module Only, Single-Plug	\$399.99
DCSPK4H1SF	Single-Plug/Single-Fire Kit	\$599.99	DCSP4H2S	Module Only, Dual-Plug	\$408.99
DCSPK4H2DF	Dual-Plug/Dual-Fire Kit	\$629.99	DCSP4HTF	Top Fuel Module Only	\$408.99
DCSPK4H2SF	Dual-Plug/Single-Fire Kit	\$759.99	DCSSC2	Shift Counter (6 Speed)	\$199.99
DCSPK4HTF	Top Fuel, Dual-Plug/Dual-Fire	\$629.99	DCSCTHD	Crank Trigger For H-D®	\$149.99
DCSTSRM2	Retard Module, 2 Cylinder	\$299.99	DCSRD1	4000SP Remote Display	\$399.99

A. S&S® Billet Generator-Style Timer/Distributor

- For any shovelhead application with a counter clockwise rotation
- Features easy installation without having to remove the heads

PART	DESCRIPTION	MSRP
SS551269	Electronic Timer, Fits '36-'69 Generator Cases	\$399.95

B. Spyke® Quick Install Distributor & Kits

- Two-piece design allows installing the distributor without removing front head
- **Recommended for use with a Spyke® or Stampede® DF Ignition Kit only**

PART	DESCRIPTION	MSRP
SPDC	Quick Install, Chrome	\$279.99
SPDCKD	Chrome Distributor, Dual-Fire Ignition, Coil & Plug Wires & Hold-Down Clamp	\$449.99

C. Spyke® 80,000 Volt Coil

- Mounts under stock covers and has a resistance rating of 3Ω.
- **Extremely quick rise and fall times all while firing at an extremely low voltage to aid in the ease of starting**

PART	DESCRIPTION	MSRP
SPC	Single-Fire Coil	\$115.00
SPCDF	Dual-Fire Coil	\$59.99

D. Dyna® Coils

- **High tech, top quality coils are designed for maximum performance!**
- Spark voltages in excess of 30,000 volts and spark energies second to none
- For three configurations and five variations of resistance for different applications
- Works with point ignitions, aftermarket or OE electronic ignitions
- Before selecting, check the ignition manufacturer's resistance requirements
- No exposed laminations for rust to degrade performance — 1 year warranty

PART	DESCRIPTION	MSRP
DC92	Four Out, 0.7Ω, Twin Fire	\$179.99
DC64	Four Out, 3.0Ω, Twin Fire	\$154.99
DC91	Dual Out, 0.7Ω	\$154.99
DC21	Dual Out, 1.5Ω	\$154.99
DC11	Dual Out, 3.0Ω	\$154.99
DC61	Dual Out, 3.0Ω For H-D®	\$79.99
DC81	Dual Out, 5.0Ω	\$154.99
DC71	Dual Out, 5.0Ω For H-D®	\$79.99
DC94	Single Out, 0.7Ω	\$154.99
DC31	Single Out, 3.0Ω	\$154.99
DC101	Single Out, 5.0Ω,	\$154.99

E. Dyna® Mini Coils

- Only 4.2" x 2.3" x 1.6"
- Advanced magnetic core technology that **delivers high output!**
- Great for customs — use with the Dyna 2000 and 3000 series ignitions, factory installed electronics, or other aftermarket ignitions that employ dwell control

PART	DESCRIPTION	MSRP
DC111	Dual Out, 0.5Ω, Mini TC (2)	\$159.99
DC112	Dual Out, 0.5Ω, Mini TC (1)	\$99.99
DC12	Dual Out, 3.0Ω, Mini (2)	\$159.99
DC13	Dual Out, 3.0Ω, Mini (1)	\$99.99
DC65	Single Out, 3.0Ω, TwinFire II Mini	\$149.99
DC121	Single Out, 0.5Ω, Mini TC (2)	\$159.99
DC122	Single Out, 0.5Ω, Mini TC (1)	\$99.99
DC32	Single Out, 3.0Ω, Mini (2)	\$159.99
DC33	Single Out, 3.0Ω, Mini (1)	\$99.99

F. Crane Cams® Hi-Intensity Coils

- The most powerful coil system available!
- **Lightweight Coils:** for use with most single fire ignitions that have current limiting control—they require a 2.8-3.2Ω coil
- For '70-'99 carbureted Evolution® & '71-Later XL, excludes XL1200S unless noted

PART	DESCRIPTION	MSRP
CR83001	Single Fire Coil	\$166.27
CR83002	Dual Fire Coil	\$100.96
CR83005	Lightweight Single Fire Coil	\$178.24
CR83006	Lightweight Dual Fire Coil	\$100.96
CR83010	Single-Fire Coil For '99-Later TC88® w/ Carb	\$132.97

A.



B.



C.

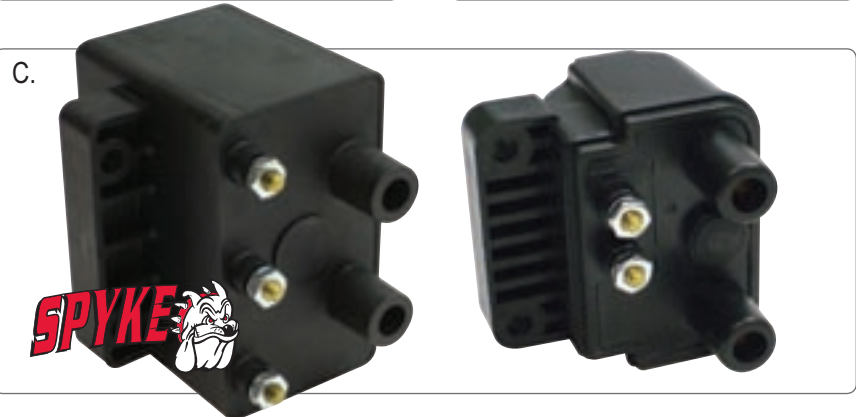

D.

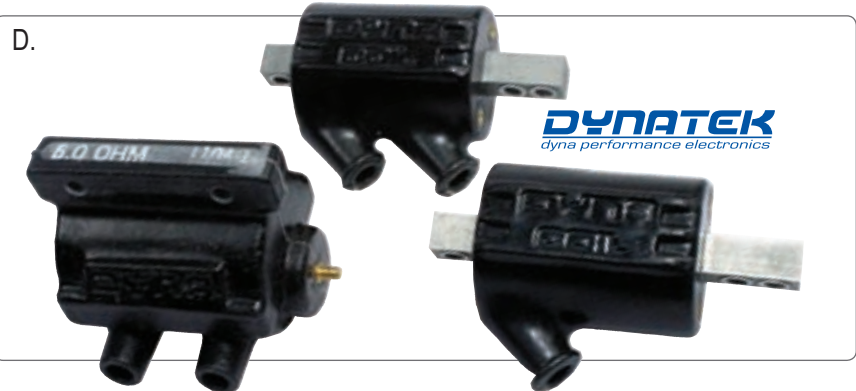

E.



F.





A.



B.

A. S&S® High Output Single-Fire Coil

Fits great with S&S® Ignitions. Features a 2-in-1 design. Not compatible with S&S VFI. SS551571 S&S® Single-Fire Coil \$129.95

B. Daytona Twin Tec Mini Coil

- Compare to Nology Profire™ PFC-30-S — same size and specs at a lower price!
- 3Ω primary resistance — compatible with most aftermarket single fire ignitions
- Sold as single coil (two required) or complete kit

PART	DESCRIPTION	MSRP
DAMINICOIL	3Ω Mini Coil	\$56.00
DAMINICOILKIT	3Ω Mini Coil Kit w/ 2 Coils & Spark Plug Set	\$112.00



NEW



C.

C. Daytona Twin Tec High Output Coils

- Fits most '99-Later carbureted models (OE#31655-99)
- Greater than 50 mJ and 40,000V output for demanding performance applications
- Compare to Screamin' Eagle® #31704-99 — same size and specs at a lower price!

PART	DESCRIPTION	MSRP
DA2005	High Output Single-Fire Coil	\$86.00
DA2008	High Output Twin-Cam Coil	\$86.00

D. S&S Cycle® Guardian Diagnostic System

Use a PC with a 9-pin COM port to turn on the break-in rev limit, adjust the final rev limit, check diagnostic test codes, evaluate live data and look at engine history.

SS555075	Guardian Diagnostic System	\$349.95
----------	----------------------------	----------

E. Daytona Twin Tec Twin Scan Tools

- Twin Scan II is a great low-cost scan tool for '01-'08 H-D® w/ Delphi® & '03-'06 carbureted models — real time data display — call for a complete list of features
- Twin Scan II+ works w/ bikes using Screamin' Eagle® Tuner or Power Commander®

PART	DESCRIPTION	MSRP
DATSCAN2	Twin Scan II Low Cost Scan Tool for H-D®	\$185.00
DATSCAN2PLUSKIT	Twin Scan II+ Tuning Aid for Screamin' Eagle® Race Tuner (SERT) and Dynojet® Power Commander®	\$522.00
DATSCAN2UPGRADE	Twin Scan II Plus Upgrade Kit, Call For Details	\$410.00



D.



E.

F. Chesapeake Performance, Inc. Coil Mounts

- Mounts for Dyna® coils
- CNC milled from billet T6-6061 aluminum then chromed

PART	DESCRIPTION	MSRP
CHM502	Destruction Mount w/ Axe	\$171.98
CHM505	Destruction Mount w/ Axe, Key Hole	\$171.98
CHM507	Destruction Mount w/ Plain Front	\$171.98
CHM508	Destruction Mount, Plain w/ Key Hole	\$171.98
CHM501	Spear Mount w/ Solid Front	\$171.98
CHM504	Spear Mount, Solid w/ Key Hole	\$171.98



F.

G. Wire Plus Ignition Switch Housing & Coil Brackets

- Chromed billet, **switch not included**
- Mount to most FXR top motor mounts without threaded mounting holes
- For use with coils that have no electrical connections on the ends
- Fits new-style coils with Crane® HI-4 and Dyna® 2000i Twin Fire

PART	DESCRIPTION	MSRP
WE149	Housing w/ Coil Bracket (Stealth)	\$167.11
WE108	Housing w/ 3-Position Ignition Switch	\$98.44
WE119	Housing, w/o Switch, Chrome	\$91.57
WE120	Housing, Winged For '96-Later Fat Bob® Switch	\$93.86
WE121	Housing w/ Hi-Low & Start Switches Installed	\$155.68
WE122	Coil Cover, Chrome Billet	\$91.57
WE123	Ignition Switch, Automotive Start	\$41.12

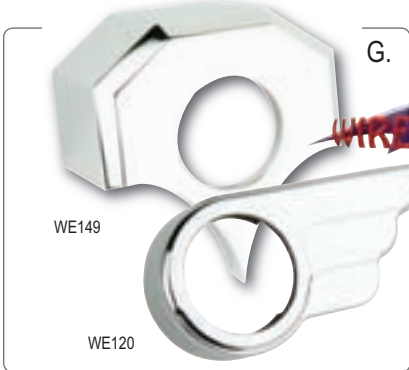

G.



H.

H. Wire Plus Custom Seat Post Ignition Switch System

- Mounts the power control module and a 3-position ignition switch
- Features three 15A breakers, start relay, diagnostic LED's and a pre-assembled harness — fits '41-'84 BT and customs

PART	DESCRIPTION	MSRP
WE133	For Stock Switches, Use w/ or w/o Turns or Auto Cancel	\$520.83
WE134	Minimal Switches w/ Chopper-Style Harness	\$520.83
WE167	For Stock Switches w/ Light Module, Incl. Harness & Breaker	\$608.97

A. Yankee Engineuity Motor & Coil Mounts w/ Accessory Provisions

Constructed from chromed billet aluminum

PART	DESCRIPTION	MSRP
YEKS01	Motor Mount Key Switch Bracket, Chromed Aluminum	\$94.78

B. Stampede™ Coil Cover w/ Motor Mount

- A cool new dimension to billet coil covers
- Easy access of plug wires with holes for the wires to pass through
- Complete with an adjustable motor mount bracket, it is made of show chromed 6061 billet aluminum
- Works with new S&S® Single-Fire Coil

PART	DESCRIPTION	MSRP
STCC03	Cover & Mount For 80"-113", S&S® 113", Chrome	\$369.99
STCC03B	Cover & Mount For 80"-113", S&S® 113", Black	\$369.99
STCC04	Cover & Mount For 111"-124", Chrome	\$369.99
STCC04B	Cover & Mount For 111"-124", Black	\$369.00
STCC	Coil Cover Only, Chrome	\$185.00
STCCB	Coil Cover Only, Black	\$184.72
ST8401	Motor Mount Only, 80"-113", S&S® 113", Chrome	\$184.72
ST8401B	Motor Mount Only, 80"-113", S&S® 113", Black	\$184.72
ST8400	Motor Mount Only, 111"-124", Chrome	\$184.72
ST8400B	Motor Mount Only, 111"-124", Black	\$184.72



C. Yankee Engineuity Coil Covers

PART	DESCRIPTION	MSRP
YECC03	For YECB3, Polished Stainless Steel	\$111.45
YECC04	For YECB4, Polished Stainless Steel	\$71.49
YECC05	For YECB5/8, Polished Stainless Steel	\$107.40
YECNCC03	For YECB11/14/17, Chrome Billet	\$126.78
YECNCC04	For YECB09/10/11/12/13/14/15/16/17, Chrome Billet	\$126.78
YECNCC05	For YECB15 w/ Dual Perewitz Coils, Chrome Billet	\$126.78
YECNCC06	For YECB4, YECB09/10/11/12/13/14/15/16/17, Chrome	\$133.94

D. Mercury Customs ProWire System



- An amazingly simple solution in wiring for custom-built motorcycles.
- This module provides termination points for, and power supply to, all major electrical functions with printed descriptions to guide your precision wiring job.
- Contains a standard starter micro relay to trigger your starter solenoid.
- Overall size of ProWire is a minimal 1.25" x 4.25" x .75", plus 1.1" added depth with starter relay installed. It can be mounted in virtually any location. Sample wiring diagram with suggested installation is included

MRPW	ProWire Wiring Management System	\$159.99
MRPWBP	Cover/Bracket, Bolt-On, Black Powdercoat	\$84.99
MRPWB	Cover/Bracket, Weld-On, Raw	\$84.99

E. Bulletprüf® Steel Coil Bracket & Motor Mount



PART	DESCRIPTION	MSRP
BPMM020	Heavy Duty Steel w/ Hole For Ignition, Chrome	\$32.44

B.



C.





A. P.B. Choppers Coil Covers w/ Motor Mounts

- Made from 16 gauge steel for any H-D® Evolution® or S&S® V-Series engine
- PJCTFCG has on/off/start switch, accepts a DDH3015, 2 1/16" Speedo
- PJCTC is pre-drilled to install stock H-D® switches, chrome hole plug is available
- All covers except for Diamond will receive Spyke® or Dynatek® dual-fire and single-fire coils — Diamond cover can receive most dual-fire and mini coils

PART	DESCRIPTION	MSRP
PJCDC	Diamond Coil Cover w/ Motor Mount, Chrome	\$442.99
PJCDCB	Diamond Coil Cover w/ Motor Mount, Black Nickel	\$573.99
PJCTFC	Flat Teardrop Coil Cover w/ Motor Mount, Chrome	\$442.99
PJCTFCB	Flat Teardrop Coil Cover w/ Motor Mount, Black Nickel	\$573.99
PJCTFCG	Flat Teardrop Coil Cover w/ Switches & Mount, Chrome	\$549.99
DDH3015	Dakota Digital Mini Graphic Speedo/Tach, 2 1/16"	\$469.95
PJCTC	Cast Teardrop Coil Cover w/ Motor Mount, Chrome	\$442.99

B. Yankee Engineuity Motor & Coil Mounts w/ Accessory Provisions

Separate components available, see MCAdvantages.com

PART	DESCRIPTION	MSRP
YEMM01	For '86-Later FXR, Polished	\$138.78
YEMM02	Top Motor Mount Only For '48-'84 BT, Polished	\$136.06
YEMM03	For '48-'84 BT, Polished	\$146.15
YEMM04	For '86-'99 Softail®, Polished	\$142.47
YEMM08	For '86-'99 Softail®, Top Motor Mount Only, Polished	\$136.92
YEMM05	For '91-'98 Dyna®, Polished	\$136.06
YEMM06	For '84-Later XL, Polished	\$152.98
YEMM09	For '00-Later Softail®, Polished	\$146.80
YEMM10	For S&S® V-Series Engines, Polished	\$146.80
YEMM11	For EFI Twin Cams, Polished	\$172.72

Yankee Engineuity Motor Mounted Coil Brackets



- Constructed from polished billet aluminum

PART	DESCRIPTION	MSRP
YECB04	For Dual Dyna or RevTech® Post-Type Coil	\$132.92
YECB06	For Single Dyna or RevTech® Post-Type Coil	\$122.59
YECB09	For '80-'99 H-D® Coils	\$93.87
YECB10	For Dyna Twin Fire Coil w/ Dual Plug Apps Coil	\$97.17
YECB11	For Single Perewitz Coil	\$93.87
YECB12	For Compu-Fire® 1 & 2 Coil	\$110.32
YECB13	For '99-Later Single-Fire H-D® Coil	\$93.96
YECB14	For Single Nology Coil	\$90.50
YECB15	For Dual Nology Or Perewitz Coils	\$98.56
YECB16	For Dual Dyna Mini DC1-2 Or DC3-2 Coils	\$117.56
YECB17	For Single Dyna Mini DC1-2 Or DC3-2 Coil	\$117.56



ENGINE
 FUEL SYSTEMS
 EXHAUST
 ELECTRICAL
 DRIVETRAIN
 WHEELS
 SUSPENSION
 SHEETMETAL
 FRAMES
 CONTROLS
 LIGHTING
 BAGGERS
 TOOLS
 APPAREL

A. Yankee Engineuity Frame Mounted Coil Brackets

Constructed from polished billet aluminum

PART	DESCRIPTION	MSRP
YECB01	For '65-'99 H-D® Coil	\$52.14
YECB02	For '48-'82 BT, Single Dyna or RevTech® Post-Type Coil	\$112.47
YECB03	For '48-'82 BT, Dual Dyna or RevTech® Post-Type Coil	\$122.61
YECB05	For '86-Later Softail®, Dual Dyna/RevTech® Post-Type Coil	\$140.08
YECB07	For '82-'95 XL, Dual Dyna or RevTech® Post-Type Coil	\$116.46
YECB08	For '91-Later Dyna®, Dual Dyna/RevTech® Post-Type Coil	\$183.94



B. Yankee Engineuity Coil Brackets For Nology Coils

• Constructed from polished billet aluminum

PART	DESCRIPTION	MSRP
YENC01	For Single Nology Coil On '82-'85 BT & '86-Later Softail®	\$62.50
YENC02	For Dual Nology Coil On '82-'85 BT & '86-Later Softail®	\$64.96
YENC05	For Single Nology Coil On '79-Later XL	\$68.16
YENC06	For Dual Nology Coil On '79-Later XL	\$68.27
YENC08	For Single Nology Coil On '91-Later Dyna®	\$60.56
YENC09	For Dual Nology Coil On '91-Later Dyna®	\$64.96

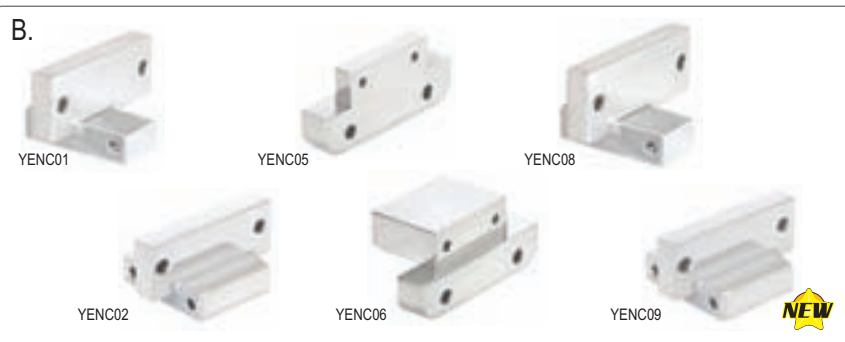

C. - D. Novello Handlebar Wiring Harness Extensions & Kits

• The ultimate in clean and simple wiring jobs — call for '08 fitments!

• Kits are 44" long, color-coded and include shrink tube pieces

• Kit can be used for stock or custom applications. Assembled per side in shrink tube — optional kit includes male & female pins for complete wiring job

• To help with those extra-long wiring jobs, Novello has handy extension kits for almost any setup. Kits include wires and shrink tube

PART	DESCRIPTION	MSRP
NVWHR44	Wire Harness Kit, 44", 12-Color Coded, 2-Pc. 3/8" Shrink Tube	\$21.95
NVWHR44C	Wire Harness Kit, 44", 12-Color Coded, 2-Pc. 3/8" Shrink Tube 24-Pc. 1/8" Shrink Tube	\$25.95
NVWH44CP	Wire Harness Kit, 44", 12-Color Coded, 2-Pc. 3/8" Shrink Tube 24-Pc. 1/8" Shrink Tube, 12-Pc. Male & 12-Pc. Female Pins	\$37.95

PART	DESCRIPTION	MSRP	PART	DESCRIPTION	MSRP
Models w/o Cruise Control			Models w/ Radio		
NVWH4	4", '97-'06 Models	\$41.95	NVWHR4	4", '97-'06 Models	\$34.95
NVWH47	4", '07 Models	\$48.95	NVWHR47	4", '07 Models	\$42.95
NVWH8	8", '97-'06 Models	\$44.95	NVWHR8	8", '97-'06 Models	\$35.95
NVWH87	8", '07 Models	\$37.95	NVWHR87	8", '07 Models	\$47.95
NVWH2	12", '97-'06 Models	\$47.95	NVWHR12	12", '97-'06 Models	\$38.95
NVWH127	12", '07 Models	\$56.95	NVWHR127	12", '07 Models	\$40.95
NVWH5	15", '97-'06 Models	\$49.95	NVWHR15	15", '97-'06 Models	\$41.95
NVWH157	15", '07 Models	\$42.95	NVWHR157	15", '07 Models	\$42.95
Models w/ Cruise Control			Models w/ Radio & CB		
NVWH4CC	4", '97-'06 Models	\$51.95	NVWHRC4	4", '97-'06 Models	\$41.95
NVWH4CC7	4", '07 Models	\$62.95	NVWHRC47	4", '07 Models	\$42.95
NVWH8CC	8", '97-'06 Models	\$56.95	NVWHRC8	8", '97-'06 Models	\$46.95
NVWH8CC7	8", '07 Models	\$64.95	NVWHRC87	8", '07 Models	\$47.95
NVWH12CC	12", '97-'06 Models	\$47.95	NVWHRC12	12", '97-'06 Models	\$48.95
NVWH12CC7	12", '07 Models	\$69.95	NVWHRC127	12", '07 Models	\$50.95
NVWH15CC	15", '97-'06 Models	\$62.95	NVWHRC15	15", '97-'06 Models	\$49.95
NVWH15CC7	15", '07 Models	\$74.95	NVWHRC157	15", '07 Models	\$52.95

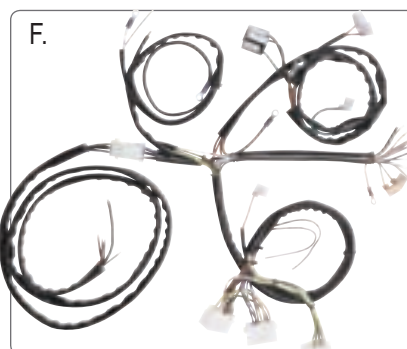
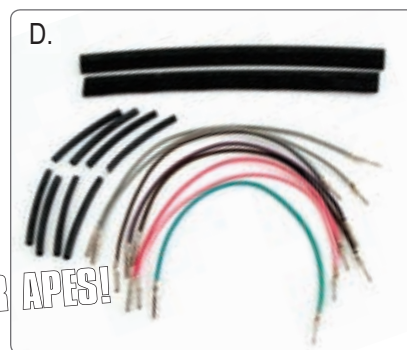

E. Grandeur Cycle® Wire Harness

Easily wire your bike from the headlight to the taillight and everything in between. The kit includes color coded wire with protective covering, four sizes of heat shrink tubing, wire end terminals, fuses and fuse holders, and solder. Includes easy to follow diagram.

GRWK	Complete Wiring Harness	\$49.95
------	-------------------------	---------

F. Stampede Wiring Harness For Softail®

This is a solidly built, preassembled and complete wiring harness for custom/Softail® models

MS001	Complete Wiring Harness	\$129.99
-------	-------------------------	----------



G. Compu-Fire® Spark Plug Wires

• 8mm spiral-wound plug wire set for four-plug applications

• Use with all custom applications utilizing single or dual plug heads and any coil combination

CF40100	Single Spark Plug Wire Set, 2 Wires	\$15.71
---------	-------------------------------------	---------

CF40200	Dual Spark Plug Wire Set, 4 Wires	\$31.49
---------	-----------------------------------	---------





A.

A. Taylor High Performance 8mm Pro Wire

- 100% Silicone-jacketed wires allow for maximum energy transfer
- Resistor core wires
- Maximum durability and heat protection
- Provides for optimum spark and max horsepower

PART	DESCRIPTION	MSRP
MCWB	Universal Black	\$18.00
MCWR	Universal Red	\$18.00
MCWL	Universal Blue	\$18.00
SPWFXR	For FXR, Black	\$18.00
SPWST	For Softail®, Black	\$18.00

B. Neon Hot Wires Plug Wires

- A direct replacement for a spark plug wire — except it lights the night!
- Crafted using only the highest quality materials
- Made of glass — but still very durable
- They will never burn out — guaranteed
- Requires no wiring or transformer
- Just plug them into the coil and attach to the spark plug
- Specifically made for H-D®
- Select a model and then a color, it's that simple



PART	DESCRIPTION	MSRP
Neon Hot Wires For '84-'99 Softail®, Pair:		
NHLKA1L	Blue Neon	\$199.99
NHLKA1G	Green Neon	\$199.99
NHLKA1O	Orange Neon	\$199.99
NHLKA1P	Purple Neon	\$199.99
NHLKA1R	Red Neon	\$199.99
NHLKA1B	Blacklight Neon	\$199.99
Neon Hot Wires For '00-Later Softail®, Pair:		
NHLKA2L	Blue Neon	\$199.99
NHLKA2G	Green Neon	\$199.99
NHLKA2O	Orange Neon	\$199.99
NHLKA2P	Purple Neon	\$199.99
NHLKA2R	Red Neon	\$199.99
NHLKA2B	Blacklight Neon	\$199.99
NHLKA2CL	Blue Neon	\$199.99
NHLKA2CR	Red Neon	\$199.99
Neon Hot Wires For '92-'98 Dyna®, Pair:		
NHLKA3L	Blue Neon	\$199.99
NHLKA3G	Green Neon	\$199.99
NHLKA3O	Orange Neon	\$199.99
NHLKA3P	Purple Neon	\$199.99
NHLKA3R	Red Neon	\$199.99
NHLKA3B	Blacklight Neon	\$199.99
NHLKA3Y	Yellow Neon	\$199.99
Neon Hot Wires For '99-Later Dyna®, Pair:		
NHLKA4L	Blue Neon	\$199.99
NHLKA4G	Green Neon	\$199.99
NHLKA4O	Orange Neon	\$199.99
NHLKA4P	Purple Neon	\$199.99
NHLKA4R	Red Neon	\$199.99
NHLKA4B	Blacklight Neon	\$199.99

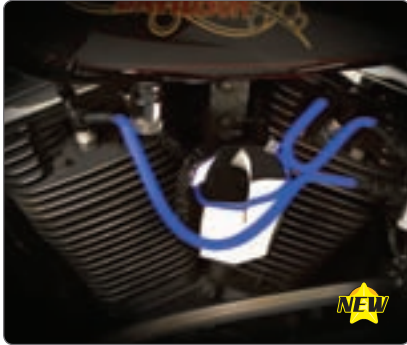

NEW



NEW



NEW



NEW



NEW



NEW

D. Spyke® SuperFlex Battery Cables w/ Extra Ground Cable

	Grd.	Pos.	Extra Grd.	
For All FXST & FLST Softail®				
'89-Later	7"	13"	13"	SPBS89
'84-'88	7"	18" & 15"	13"	SPBS84
For All FLH & FXE				
'65-'85	8"	15" & 15"	13"	SPBF65
For All Sportster®				
'97-Later All XL	13"	11"	N/A	SPBX97
'81-'96 All XL	11"	13"	N/A	SPBX81
'67-'80 XL, XLH, XLCH	9"	16" & 6"	N/A	SPBX67
'77-'78 XLCR	13"	16" & 6"	N/A	SPBX77

	Grd.	Pos.	Extra Grd.	
For All FLT, FLHT, FLHS, FLHR Dresser Models				
'94-Later	9"	15"	14"	SPBF94
'89-'93	9"	34"	34"	SPBF89
'80-'88	9"	31" & 8"	10"	SPBF80
For All FXR				
'87-'94, '99-'00	13"	17"	9"	SPBR87
'82-'88	13"	7" & 17"	9"	SPBR82
For All FXD Dyna®				
'97-Later	13"	13"	7"	SPBD97
'91-'96	7"	13"	11"	SPBD91
Universal				SPB6U



- High-strand, flexible cable (#4 gauge—1,672 strands) with low resistance, 99.9% pure finely stranded electrolytic copper conductors.
- Temperature resistant up to 105° C
- Highly resistant to oil, water, acids, alkali, ozone, grease and diesel fumes
- Shiny black with 24k gold-plated connectors for a better connection

A. Thunderstart™ Batteries

- Maintenance-free glassmat with the most cranking amps pound per pound
- Leakproof pressurized vent system, its race-proven technology fights vibration
- Massive dual terminal allows for multi-option hookup
- **Two year warranty (unless noted)!**

TS12	12V 12A 240 CCA (5 7/8" L x 5 1/8" H x 3 1/2" W)	\$142.99
TS14	12V 14A 280 CCA For '02-Later V-Rod® (5 15/16" L x 5 11/16" H x 3 1/2" W)	\$142.99
TS16L	12V 19A 375 CCA For '91-'96 FXD/FXST (6 7/8" L x 6 1/8" H x 3 15/16" W)	\$142.99
TS18	12V 20A 400 CCA For '80-'96 FL/FLH (8 1/8" L x 6 7/16" H x 3 9/16" W)	\$157.99
TS20	12V 18A 375 CCA For '71-'00 FX/FXR '84-'90 FXST/FLST '70-'96 XL (6 7/8" L x 6 1/8" H x 3 15/16" W)	\$142.99
TS20L	12V 18A 345 CCA For '97-Later FXD/FXST/FLST, '97-'03 XL (6 15/16" L x 6 1/8" H x 3 1/2" W)	\$142.99
TS30	12V 30A 365CCA For '97-Later FLT/FLHT (6 5/8" L x 5 3/16" H x 6 7/8" W)	\$169.99

**SMALL SIZE. BIG PUNCH.
CUSTOM COMPACT
BATTERY.**

For custom bike builders or anyone needing a great battery that's small, the TS12 can lay in any position and has multi-access terminals. **One year warranty.** (5 7/8" L x 5 1/8" H x 3 1/2" D)



TS12	12V 12A 240 CCA (5 7/8" L x 5 1/8" H x 3 1/2" W)	\$142.99
------	--	----------

B. Bulletprüf® Batteries

- Most gel batteries have a 90% gas recombination efficiency rating—Bulletprüf's boasts 95%!
- Maintenance-free, valve-regulated design eliminates acid spills and terminal corrosion with little chance of acid spray, fumes and explosion.
- Durable construction resists vibration and prevents damage — mount in any position
- **One year warranty (unless noted)!**

BPBA12V13L	12V 13A 250 CCA Spacesaver For Customs & Buell® (6 7/8" L x 5 1/8" H x 3 1/4" W)	\$128.99
BPBA12V20L	12V 18A 300 CCA '97-Later FXST/FLST/FXD, '97-'03 XL (6 7/8" L x 6 1/8" H x 3 7/16" W)	\$128.99
BPBA12V20	12V 18A 300 CCA '71-Later XL/FXR/FXE/FX/FLST (6 7/8" L x 6 1/8" H x 3 7/16" W)	\$128.99
BPBA12V22	12V 20A 350 CCA Most '80-'96 FLT/LFHT/FLHR (8 1/8" L x 6 7/16" H x 3 9/16" W)	\$128.99
BPBA12VX30LB	12V 28A 450 CCA '97-Later FLT/FLH (6 9/16" L x 6 15/16" H x 4 15/16" W)	\$171.99

C. Spyke® SuperStart Plus Batteries

- SuperStart Plus batteries were on board as a Spyke-sponsored Bonneville Racer cranked over two S&S® 145's and hit 218 MPH!
- Vibration resistant and maintenance-free glassmat technology
- **Two year warranty (unless noted)!**

PART	DESCRIPTION	MSRP
SP12P	(5 7/8" L x 5 1/8" H x 3 1/2" D) 12V 12A 240 CCA	\$142.99
SP14P	(5 15/16" L x 5 11/16" H x 3 1/2" W) 12V 14A 280 CCA	\$142.99
SP16LP	(6 7/8" L x 6 1/8" H x 3 15/16" W) 12V 19A 375 CCA	\$142.99
SP18P	(8 1/8" L x 6 7/16" H x 3 9/16" W) 12V 20A 400 CCA	\$157.49
SP20P	(6 7/8" L x 6 1/8" H x 3 15/16" W) 12V 18A 375 CCA	\$142.99
SP20LP	(6 15/16" L x 6 1/8" H x 3 1/2" W) 12V 18A 345 CCA	\$142.99
SP30P	(6 5/8" L x 5 3/16" H x 6 7/8" W) 12V 30A 365 CCA	\$169.99

A.

**TWO YEAR
WARRANTY**

Thunderstart



B.



NEW

C.

**TWO YEAR
WARRANTY**





A.

Battery Tender® Plus

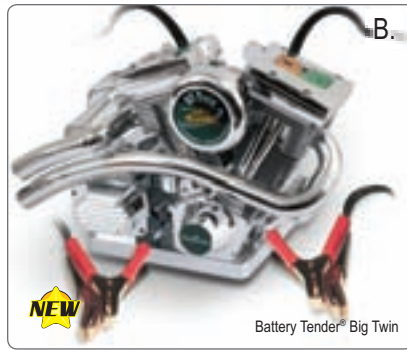

B.

Battery Tender® Big Twin



C.

Battery Tender® Junior



D.

Battery Tender® 800



E.

Battery Tender® Tester



Battery Tender Accessories (Not Shown)

PART	DESCRIPTION	MSRP
BT5000017	Pouch For Plus, Junior & Int'l	\$4.95
BT8100696	QD Replacement Ring Terminals, Fused, 2-Pin, Black	\$6.95
BT8100694	QD Replacement Ring Terminals, 2-Pin, Black	\$4.95
BT81014825	QD Extension Cable, 25'	\$11.95



CF55120

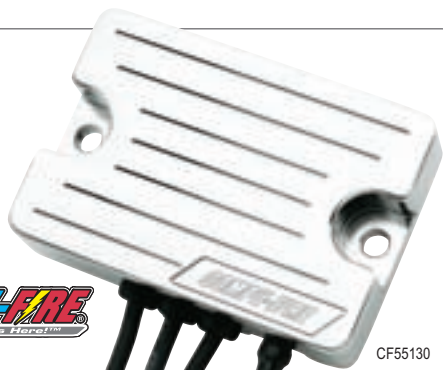

CF55130



G.



H.

A. Battery Tender Plus

- Sound design, reliable components — 10 year warranty
- 120 VAC 60 Hz input
- Includes ring terminals and alligator clips with black (12V) or white (6V) QDC

PART	DESCRIPTION	MSRP
BT210144	Battery Tender Plus, 6V, 1.25 A	\$59.95
BT210128	Battery Tender Plus, 12V, 1.25 A	\$59.95
BT210156	Battery Tender Plus, 12V, 1.25 For Gel Batteries	\$59.95

B. Battery Tender Big Twin Battery Chargers

- Dual, independent output circuits for two batteries at the same time
- Detachable, extra long (15 ft.) DC output cables mate with fused ring terminal and alligator clip harnesses with black QDC (12V), included
- 100-240 VAC 50 / 60 Hz Input
- Push the red button to hear the V-Twin roar
- Three year warranty

PART	DESCRIPTION	MSRP
BT800DLWH	Big Twin Battery Charger, Dual Output (800 mA Ea.)	\$169.95

C. Battery Tender Junior Battery Chargers

- Big charge in a smaller package — five year warranty
- Includes ring terminals and alligator clips with black (6V & 12V) QDC

PART	DESCRIPTION	MSRP
BT210141	Battery Tender Junior, 12V	\$39.95
BT210142	Battery Tender Junior, 6V	\$39.95

D. Battery Tender 800, Waterproof

- Waterproof, vibration and shock resistant with a three year warranty
- Includes ring terminals and alligator clips with black QDC (12V)
- Portable or permanent mount

PART	DESCRIPTION	MSRP
BT210143	Battery Tender 800, Waterproof	\$49.95

E. Battery Tender PST-100 Battery Tester

- Fast results in less than 6 seconds — portable, lightweight

PART	DESCRIPTION	MSRP
BT260001	PST-100 Battery Tester For 12V Batteries	\$249.95

F. Compu-Fire® Voltage Regulators

- Series type circuitry that allows both the stator and regulator to operate at a lower temperature by controlling the stator output
- When the battery reaches full charge, the stator output is switched off by the regulator
- The output voltage of the regulator is calibrated to meet the charging requirements of modern maintenance free batteries
- Available in a chrome billet or black finned case

PART	DESCRIPTION	MSRP
CF55150	38 Amp (Single Phase) For '98-Later TC, Black Finned Case	\$213.31
CF55130	32 Amp For '89-'99 BT, Chrome Billet Case	\$145.50
CF55120	32 Amp For '89-'99 BT, Black Finned Case	\$85.64
CF55121	22 Amp For '81-'88 BT, Black Finned Case	\$91.48
CF55125	22 Amp For '91-'99 XL, Black Finned Case	\$85.64

G. Crane Cams® Voltage Regulators

- Performance-designed as a direct bolt-on replacement for stock H-D® regulators
- Delivers full-range of normal operating and charging with stock H-D® charging system or any 26-32 amp alternator
- Attractively finished in bright nickel-chrome double-plating
- Comes complete, ready for bolt-on installation on any stock chassis
- Traditional Crane Cams® quality, performance and value in a budget priced, performance replacement voltage regulator

PART	DESCRIPTION	MSRP
CR84060	Voltage Regulator For '88-'98 BT, Chrome	\$120.64
CR84061	Voltage Regulator For '81-'84 BT, Chrome	\$120.64

H. Regulator Mounting Bracket

Easily bolt-up a regulator with this raw steel bracket.

PART	DESCRIPTION	MSRP
GRVRB	Regulator Mounting Bracket	\$20.00

A. Bulletpruf® 32 Amp Charging Systems

- Economical, durable OE replacement system, selected to meet strict standards
- **Voltage regulator carries lifetime warranty!**
- Fits '70-'99 Big Twins (regulator features lifetime warranty)

PART	DESCRIPTION	MSRP
BPCSC	System w/ Chrome Regulator For '70-'99 BT	\$179.00
BPCSB	System w/ Black Regulator For '70-'99 BT	\$165.00
BPCSR	32 Amp Rotor	\$76.99
BPCSS	32 Amp Stator	\$61.49

B. Spyke® 32 Amp Complete Charging Systems

- **Forged steel rotor and thicker spline for maximum engagement**
- Magnets are encapsulated to prevent vibration-related breakage
- Includes a high performance stator and voltage regulator (regulator features lifetime warranty)
- Additional regulators available for most models, see MCAAdvantages.com

PART	DESCRIPTION	MSRP
SPCSK	'70-'99 Big Twin (Black Volt Reg.) 32 Amp	\$244.87
SPCSKC	'70-'99 Big Twin (Chrome Volt Reg.) 32 Amp	\$265.10

See Price List For Complete Fitment Listing In Chrome Or Black

SPCSS	Stator, 32 Amp (OEM #29970-88B)	\$64.99
SPSR	Rotor, '70-Later Big Twin (Black)	\$142.99
SPCSVR	Voltage Regulator, All BT w/ 32 Amp System OEM #74519-88, Black (Lifetime Warranty)	\$69.99
SPCSVRC	Voltage Regulator, All BT w/ 32 Amp System OEM #74519-88, Chrome (Lifetime Warranty)	\$89.99

C. Compu-Fire® 40 Amp 3Phase Charging System

- 3Phase charging systems provide 25 amps at idle and 40 amps continuously above 2800 RPM
- Narrow rotor and stator combination fits Softail®/Dyna® primary cases and the voltage regulator bolts on without any frame modifications
- The precision balanced vented rotor keeps the stator cooler in closed primary systems to maintain maximum output under all high current draw conditions
- The large flanged seal spacer provides maximum support for the rotor and the voltage regulator output is calibrated to 14.25 volts from idle on up

PART	DESCRIPTION	MSRP
CF55560	For '81-'99 BT, Vented Rotor	\$411.90
CF55570	For '81-'99 BT, Non-Vented Rotor	\$411.90
CF55565	For '03-'06 TC (Excludes '06 Dyna®), Vented Rotor	\$411.90
CF55575	For '03-'06 TC (Excludes '06 Dyna®), Non-Vented Rotor	\$411.90
CF55566	For '99-'02 TC, Vented Rotor	\$411.90
CF55576	For '99-'02 TC, Non-Vented Rotor	\$411.90

D. Compu-Fire® 32 Amp Charging Systems

- Includes a custom wound stator with the correct engine case plug, a precision balanced rotor with the magnets permanently attached
- Splined center hole is designed to properly fit either OE or aftermarket engines
- Black finned series type voltage regulator has the voltage output calibrated to meet maintenance free battery requirements

PART	DESCRIPTION	MSRP
CF55520	For '81-'99 Carbureted Evolution®, 32 Amp	\$257.06
CF55522	For '98-'03 Carbureted Twin Cam, 32 Amp	\$420.33
CF55540	For '81-'99 Aftermarket BT, 32 Amp	\$266.71
CF55530	Stator Only For '81-'99 Aftermarket BT	\$82.07
CF55534	Stator Only For '98-'03 Carbureted Twin Cam	\$120.11
CF55650	Rotor Only For '81-'99 Aftermarket BT	\$117.66
CF55600	Rotor Only For '98-'03 Carbureted Twin Cam	\$107.15

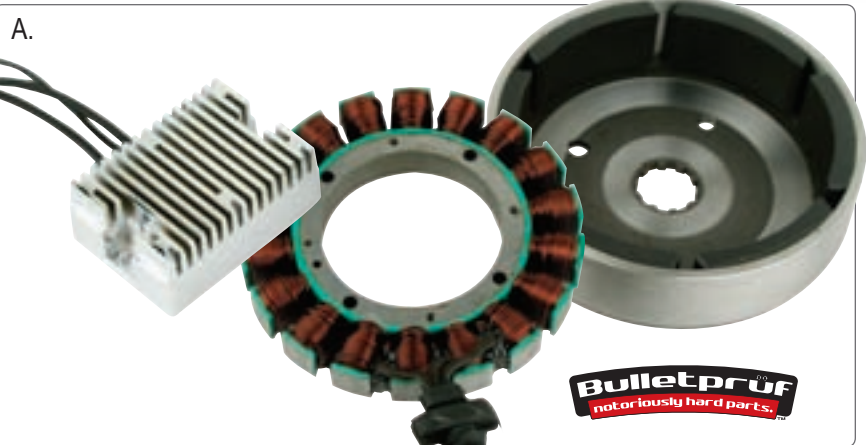

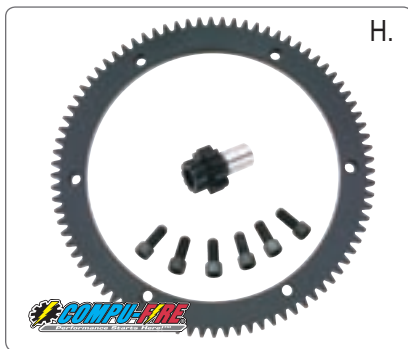
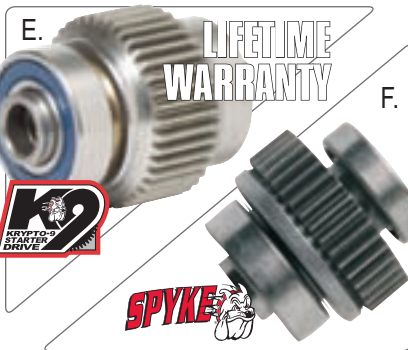
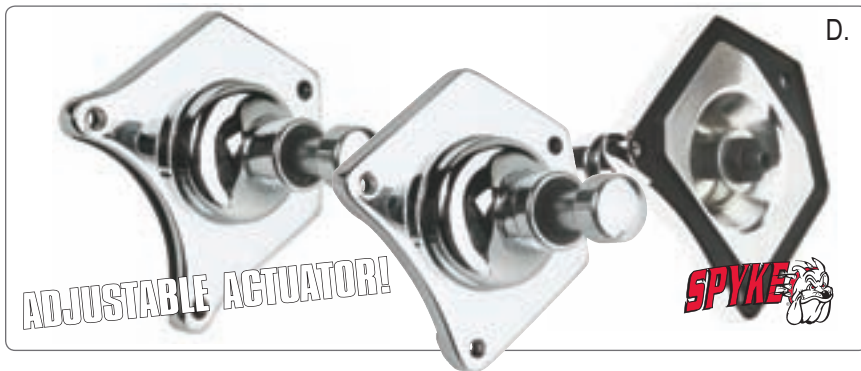
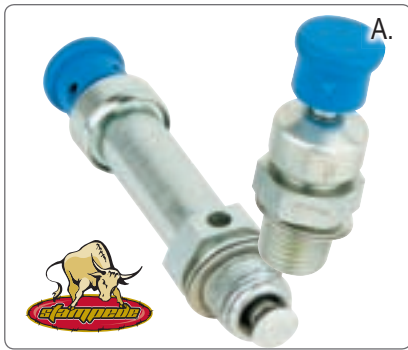

A. Stampede™ Compression Release Valve

- Start your bike easily and save wear on your battery and starter
- Requires drill and tap of head to install
- 10mm X 1.0 thread pitch

PART	DESCRIPTION	MSRP
STCR382	60.5mm Long, 3.0 Throttle Drilling, Single	\$19.99
STCR692	36mm Long, 1.0 Throttle Drilling, Single	\$19.99

B. Bulletproof™ Compression Release Button Covers

- Chromed billet aluminum cap fits literally thousands of releases
- Great looks with easy glue-on installation to the existing button

PART	DESCRIPTION	MSRP
BP5000	Compression Release Button Cover	\$19.95

C. S&S® Compression Release Kits

PART	DESCRIPTION	MSRP
SS904915	Electronic Compression Release Kit	\$289.95
SS904925	Manual Compression Release Kit	\$274.95

D. Spyke® Starter Buttons

- Internally adjustable actuator
- Machined from triple show-chrome plated billet 6160 aluminum
- Adjusts from 9 volts to 12 volts during starter actuation

PART	DESCRIPTION	MSRP
SPSB14	For 1.2kw & 1.4 kw	\$69.99
SPSB18	For 1.6kw & 1.8 kw	\$69.99
SPSB24	For 1.0kw, 2.4 kw & '03-'04 Big Dog®	\$69.99

E. Spyke® Krypto-9 Upgrade Starter Drive

- The ultimate in starter drive strength, now with a lifetime warranty!
- Fits 1.4 kw Spyke® starters and other makes needing a beefed up drive
- The sprags of the drive are made with 52100 hardened high carbon alloy steel
- The double cage construction provides full phasing that gives the drive a tighter fit in the starter and prevents friction for years of uninterrupted use!

PART	DESCRIPTION	MSRP
SPSDK18	For '89 H-D®, 1.8/2.4 Spyke & Other 1.6-2.4kw Starters	\$285.70
SPSDK	For '90-Later XL, Spyke 1.4kw & Other 1.2-1.4kw Starters	\$185.70

F. Spyke® Replacement Starter Drive Clutch

OEM #31663-90 For Big Twins '90-later

PART	DESCRIPTION	MSRP
SPSD	Starter Drive	\$100.00

G. Spyke® Solenoid Repair Kit

- Includes plunger and 2 sets of contact points — one for Spyke, one for OE
- Use the ones that match those being replaced and discard the others

PART	DESCRIPTION	MSRP
SPSPK12	Solenoid Repair Kit for Spyke® and OE solenoid repair	\$19.99

H. Compu-Fire® 1084 Gear Set

- Increases starter torque by lowering the ratio of pinion gear to clutch ring gear
- As a replacement for the 9:66 ratio gear sets, get a 15% increase in torque
- Used as a replacement for 10:102 ratio gear sets which are prone to breaking

PART	DESCRIPTION	MSRP
CF54001	'90-'93 BT	\$189.33
CF54002	'94-'97 BT	Requires adapter for 3" BDL, call \$189.33
CF54003	'98-'06 BT (Excludes '06 Dyna®)	for details. \$189.33

I. Spyke® Pinion Conversion Kit

- Converts '94-later starters into the 9-tooth pinion gear and 66T ring gear
- Cost-effective compared to changing out the inner primary
- Provides greater contact area for higher torque and positive engagement
- Provides elevated endurance over the later model 102-tooth ring gear

PART	DESCRIPTION	MSRP
SPPG90K	'90-'97 Clutch Baskets Ring Gear	\$92.15
SPPG98K	'98-Later Clutch Baskets Ring Gear	\$92.15
SPPG	'90-Later Pinion Gear	\$71.99

STOP STARTER GRIND!



A. Bulletproof® Belt Drive Fix

- Stop starter grind immediately and easily!
- For open belt drives with one-piece jackshafts,
- Fix the "grind" from bikes with a solid or very rigid belt drive actuation
- The engineered spring and ramped teeth help integrate the teeth before the unit locks in and turns

PART	DESCRIPTION	MSRP
BPBDF	Belt Drive Fix (Excludes BDL Top Fuel)	\$79.99

B. Spyke® Starter Jackshaft

- Get more cranking power and durability working with a Spyke starter
- For '89-Later BT

PART	DESCRIPTION	MSRP
SPSJ90	Jackshaft For '89-'93 Big Twin	\$99.99
SPSJ94	Jackshaft For '94-Later Big Twin	\$99.99

C. Spyke® SuperTorque Starter For Sportster®

Designed with the same features as the 1.4kw Big Twin SuperTorque Starters.

PART	DESCRIPTION	MSRP
'81-Later XL		
SPSSP81	Polished	\$399.00
SPSSP81B	Black	\$319.00
SPSSP81C	Chrome	\$479.00
'67-'80 XL		
SPSSP67	Polished	\$499.00
SPSSP67B	Black	\$499.00
SPSSP67C	Chrome	\$579.00

D. Bulletproof® Starters

- Durable, cost-competitive OE replacement starter
- Dyno tested to meet or exceed stock starter standards
- One starter part number fits '86-'06 H-D® (Except '06 Dyna®) thanks to the special conversion through-bolt included
- *Not intended for engines larger than stock.

PART	DESCRIPTION	MSRP
BPS90	1.4kw For '86-'06 H-D® (Excl. '06 Dyna®), Chrome	\$215.00
BPS90-20	2.0kw For '86-'06 Softail® & FXR, Chrome	\$245.00

E. Compu-Fire® Gen3 Starters

- The only starters in the V-Twin industry that are engineered for cranking large displacement, high compression engines without the need for compression releases
- Produces more cranking power than 2.0kw starters with half the current draw
- The high energy neodymium magnets, high efficiency motor windings, and 6:1 planetary gear reduction are unique to this starter
- The splined output shaft, stepped jackshaft bolt and shortened case design allow just one part number to cover all '90-later BT

PART	DESCRIPTION	MSRP
CF53700	Gen3 Starter For '90-'99 BT	\$599.95
CF53900	Gen3 Starter For '99-'06 TC (Excludes '99-'05 Dyna®)	\$599.95

B.



C.



D.

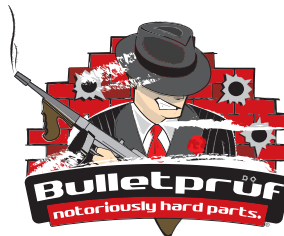

E.



TORQUE WITH STYLE!



Razzberry
 Gold
 Dark Cherry
 Copper
 Blueberry
 Blue
 Smoked Chrome
 Tarnished Brass



A. Spyke® Stealth Starters

Now with an unprecedented five year warranty when built with a super strong Krypto-9™ Starter Drive! Concealed bolts and minimal lines give way to a smooth sleek design like no other, while sporting dependable Spyke gears and gear ratios. Spyke provides a manual starter button option, available on new starters.

PART	DESCRIPTION	MSRP
1.4kw Stealth Starter, Fits '89-'93 BT (Except FLT/FLHT/FLHS)		
SPST90CK	Chrome w/ K-9 Drive	\$533.00
SPST90CX	Chrome w/ Start Button	\$529.00
SPST90C	Chrome	\$429.00
SPST90K	Polished w/ K-9 Drive	\$496.00
SPST90	Polished	\$393.00
SPST90B	Black	\$429.00
SPST90BX	Black w/ Starter Button	\$529.00
	Listed Custom Colors, Call For Availability	Call
1.4kw Stealth Starter, Fits '94-'06 BT (Except FLT/FLHT/FLHS)		
SPST94CK	Chrome w/ K-9 Drive	\$533.00
SPST94CX	Chrome w/ Start Button	\$529.00
SPST94C	Chrome	429.00
SPST94K	Polished w/ K-9 Drive	\$514.70
SPST94	Polished	\$393.00
SPST94B	Black	\$429.00
SPST94BX	Black w/ Starter Button	\$529.00
	Listed Custom Colors, Call For Availability	Call

B. Spyke® SuperTorque Starters (Big Twin)

SuperTorque Starters have superior cranking torque compared to stock. Spyke® Starters are available in chrome, polished, silver or wrinkle black. A 300 CCA battery is required for 1.8, 2.4 starters. Add K for K-9 Drive.

PART	DESCRIPTION	MSRP	PART	DESCRIPTION	MSRP
For '94-'06 BT 1.4 kw			For '02-Later All TC, 1.4 kw		
SPS94	Polished	\$329.00	SPSTC	Polished	\$339.00
SPS94B	Black	\$329.00	SPSTCC	Chrome	\$380.00
SPS94C	Chrome	\$370.00	For '94-Later Softail® & FXR Only		
SPS94S	Silver	\$329.00	SPS94-18	1.8kw, Polished	\$419.00
For '89-'93 BT Except FLT/FLHS/T, 1.4kw			SPS94-18C	1.8kw, Chrome	\$469.00
SPS90	Polished	\$329.00	For '89-'93 Softail® & FXR Only		
SPS90B	Black	\$329.00	SPS90-18	1.8kw, Polished	\$419.00
SPS90C	Chrome	\$370.00	SPS90-18C	1.8kw, Chrome	\$469.00
SPS90S	Silver	\$329.00	For '05-Later Big Dog® w/ Baker		
			SPS05-24	2.4kw, Polished	\$499.00

C. Spyke® SuperTorque Starters (Early Models)

Intelligent gear reduction design offers a 200% increase in torque over stock starters.

'65-Early '79 All FXE, FLH (S,L,K)		Mount, Coarse Gear (R,M,L)	
SPS65	Polished \$349.00	SPS80R	Polished \$349.00
SPS65B	Black \$329.00	SPS80RB	Black \$329.00
SPS65C	Chrome \$399.00	SPS80RC	Chrome \$399.00
Late '79-Early '85 FXST, FXE, FLH, FXWG (S,L,K)		'80-'86 FXWG-FXSB, '84-Early '86 FXST	
SPS79	Polished \$349.00	'82-Classic, '83-'85 FLH-80 (S,M,K)	
SPS79B	Black \$329.00	Fine Tooth Gear, Final Belt Drive	
SPS79C	Chrome \$399.00	SPS80	Polished \$349.00
'85-'88 BT, Fine Tooth Gear (R,S,M,L)		SPS80B	Black \$329.00
SPS86	Polished \$349.00	SPS80C	Chrome \$399.00
SPS86B	Black \$329.00		
SPS86C	Chrome \$399.00		

'80-'85 FLT, FLHT, FXR B.T. Rubber

R: Rubber Mount Motor

K: 4-Speed L: Chain Drive

S: Solid Mount Motor M: Belt Drive Rear

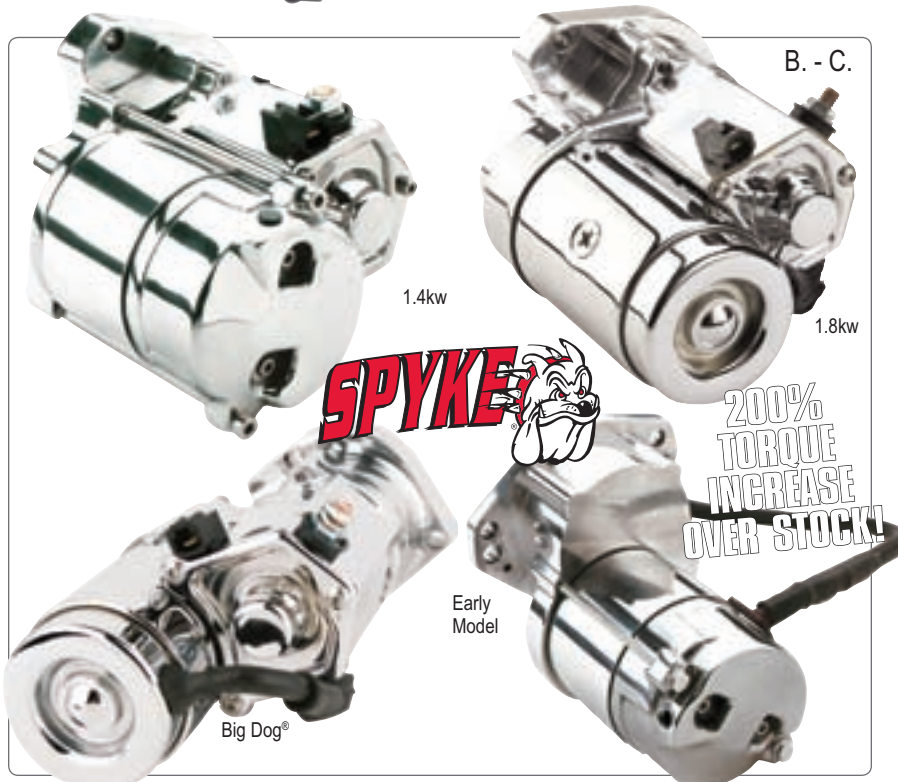

B. - C.

1.4kw

1.8kw



200% TORQUE INCREASE OVER STOCK!

Early Model

Big Dog®

A. Rivera Engineering® Variable Pressure Clutch Assist

With increased pack pressure at higher RPM, this variable pressure plate assembly is easy to pull in when shifting, but with a dramatic increase in clutching power under the influence of high horsepower for instantaneous engagement. Get up to 60% more pressure.

PART	DESCRIPTION	MSRP
	Variable Pressure Clutch Assist	Call

B. Bulletpruf® Replacement Clutch

• A durable replacement clutch with the durability and strength of an extra friction plate and steel plate

PART	DESCRIPTION	MSRP
BP411	Complete Clutch Ass'y, (8-Steel, 9-Friction) '90-'93	\$450.00

C. S&S® High-Performance Clutch

• 10 steel plates and 11 friction plates that can take the abuse of the world's biggest and baddest V-Twins

• Effectively handles over 150 horses with less grip effort than comparable OEM stock clutches

• Competition plates are available to handle 200+ horsepower applications

PART	DESCRIPTION	MSRP
SS565150	Fits '91-'05 BT w/ 36-Tooth Sprocket	\$969.95
SS565151	Fits '91-'05 BT w/ 37-Tooth Sprocket	\$969.95

D. Rivera Engineering Pro-Clutch

• Doesn't slip, whine or bog down under the influence of high horsepower engines

• Easy to install and user friendly

• The industry standard for performance clutches

PART	DESCRIPTION	MSRP
PC1000A	For All Pre-Evolution® Big Twins	\$550.00
PC1100C	For OEM Chain Drive Primary '86-'89	\$499.00
PC1200C	For OEM Chain Drive Primary '90-'97	\$499.00
PC1298C	For OEM Chain Drive Primary '98-Later	\$499.00
PC1300XL	For Sportster® 5-Speed '91-Later	\$499.00

E. Grandeur Cycle® Auto Clutch Suicide-Free Shifting

The 2006 Industry Leader Award Winner Tech Product of the Year!

• No slipping clutches

• No more clutching in slow moving traffic

• Easy installation

• Simple instructions included

• Ride up to a stoplight with the bike in gear and avoid holding the clutch in — when the light turns green, twist the throttle and ride away

• Replaces your old clutch pressure plate with a new unit that applies centrifugal pressure to your clutch pack. Your engine speed does the work that is normally done by springs to engage the clutch—and does it a lot better!

• Makes dangerous suicide shifting a thing of the past

• Upgrade to carbide engagement balls for drag racing applications!

• The neutral safety switch allows the bike to start only when it is in neutral

PART	DESCRIPTION	MSRP	PART	DESCRIPTION	MSRP
Auto Clutch For:			Auto Clutch For:		
GRACBDL	BDL, Raw	\$695.00	GRAUTO3P	3" BDL, Pol.	\$795.00
GRACBDLTF	BDL Top Fuel	\$749.00	GRACU	Ultima®, Raw	\$749.00
GRACHT	High-Tech	\$1,000.00	GRACUP	Ultima®, Pol.	\$849.00
GRACHD90	BT, '90-Later	\$1,895.00	GRACP4	Brute IV, Raw	\$749.00
GRACXL94	XL, '94-Later	\$1,895.00	GRACP4P	Brute IV, Pol.	\$849.00
			GRACHDV	V-Rod®	\$2,195.00

PART	DESCRIPTION	MSRP
GRJS8B	Jockey Shifter For 5- or 6-Speed w/ 8 Ball Knob	\$695.00
GRJS13B	Jockey Shifter For 5- or 6-Speed w/ 13 Ball Knob	\$695.00
GRJSCB	Jockey Shifter For 5- or 6-Speed w/ Cue Ball Knob	\$695.00
GRJS48B	Jockey Shifter For 4-Speed w/ 8 Ball Knob	\$696.00
GRJS413B	Jockey Shifter For 4-Speed w/ 13 Ball Knob	\$695.00
GRJS4CB	Jockey Shifter For 4-Speed w/ Cue Ball Knob	\$697.00

Accessories:

GRACCB	Carbide Ball Upgrade, Single Ball	\$6.50
GRNSSKIT	Safety Switch	\$49.95

A.



B.

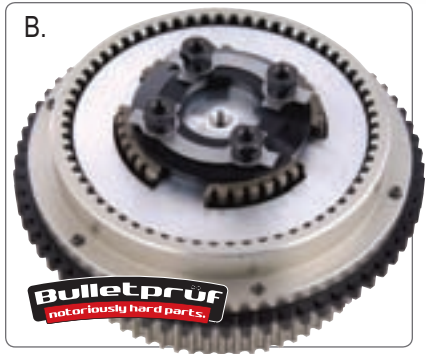

C.

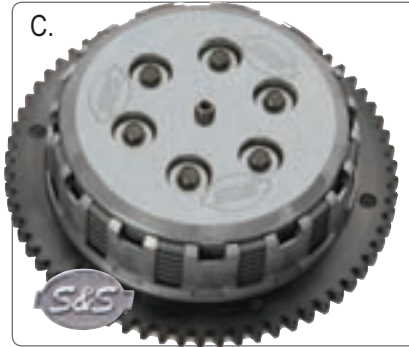

D.

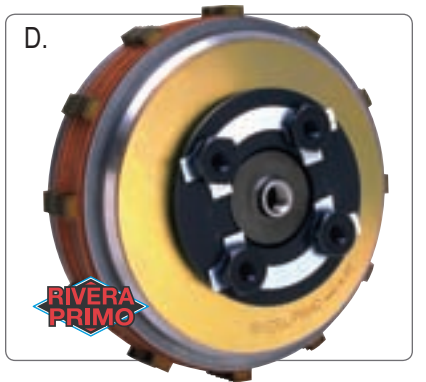

E.



Jockey Shift w/
Billiard Ball Knobs

Auto Clutch For
BDL, High-Tech & Primo®

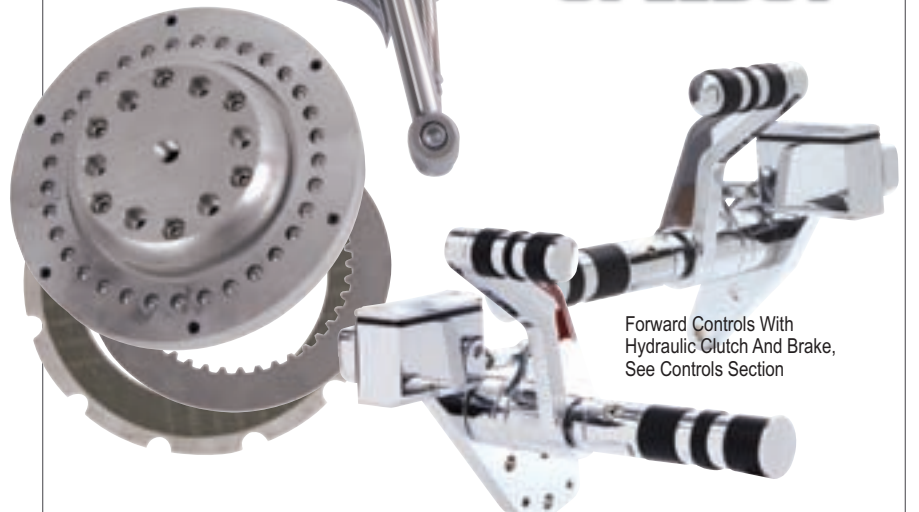

Forward Controls With
Hydraulic Clutch And Brake,
See Controls Section

NEVER
CLUTCH
AGAIN
AT SLOW
SPEEDS!



A. Bulletpruf® Clutch Plate Replacement Kits

- Made by Alto For Bulletpruf®
- Durable, cost-effective replacement clutch plates
- Each kit includes 8 steel and 9 Alto Red Eagle® or Kevlar® friction plates

PART	DESCRIPTION	MSRP
BP910	For '90-'97 w/ Wet Or Dry Clutch, Red Eagle® Friction Plates	\$99.99
BP911	For '90-'97 w/ Std. Dry Clutch, Kevlar® Friction Plates	\$149.99
BP920	For '98-Later w/ Wet Or Dry Clutch, Red Eagle® Friction Plates	\$114.99
BP921	For '98-Later w/ Std. Dry Clutch, Kevlar® Friction Plates	\$139.99
BP446	Diaphragm Spring, Heavy Duty For '90-'97 Evolution®	\$39.99
BP447	Diaphragm Spring, Heavy Duty For '98-Later Twin Cam	\$39.99

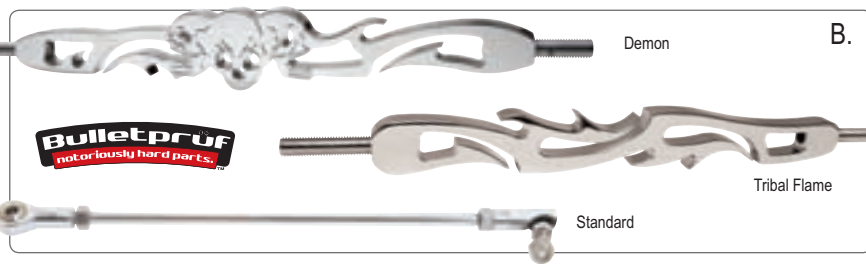

B. Bulletpruf® Shift Linkages

- Attitude and bling with chromed aluminum billet construction!
- All include heim joints

PART	DESCRIPTION	MSRP
BPSLD9	Demon Linkage, 9", Chrome	\$90.76
BPSLD10	Demon Linkage, 10.25", Chrome	\$96.80
BPSLD12	Demon Linkage, 12.25", Chrome	\$100.82
BPSLF	Tribal Flames Linkage, 9", Chrome	\$90.76
BPSREJF	End Joints, Female, Chrome	\$14.99
BPSREJM	End Joints, Male, Chrome	\$14.99

OE Replacement Linkages

BPSLH	Standard Length. Set, Chrome	\$27.99
BPSLH2	+2", Set, Chrome	\$29.99
BPSLH3	+3", Set, Chrome	\$28.99



C. Detroit Bros.® Shift Linkages

- Available in a long and short versions
- 5/16"-18 threads and 5/16"-18 nipples included
- Twist versions are chromed billet aluminum while the chains are polished

PART	DESCRIPTION	MSRP
DBSL3L	MotoChain Long Shift Linkage, 14"-15 1/2"	\$139.99
DBSL3S	MotoChain Short Shift Linkage, 12"-13 1/2"	\$119.99
DBSL2L	Classic Twist Long Chain Shift Linkage, 13 1/2"-15 1/2"	\$139.99
DBSL2S	Classic Twist Short Shift Linkage, 11 1/2"-13 1/2"	\$119.99
DBSL4L	Proof Coil Long Chain Shift Linkage, 14"-15. 1/2"	\$139.99
DBSL4S	Proof Coil Short Chain Shift Linkage, 12"-13 1/2"	\$119.99

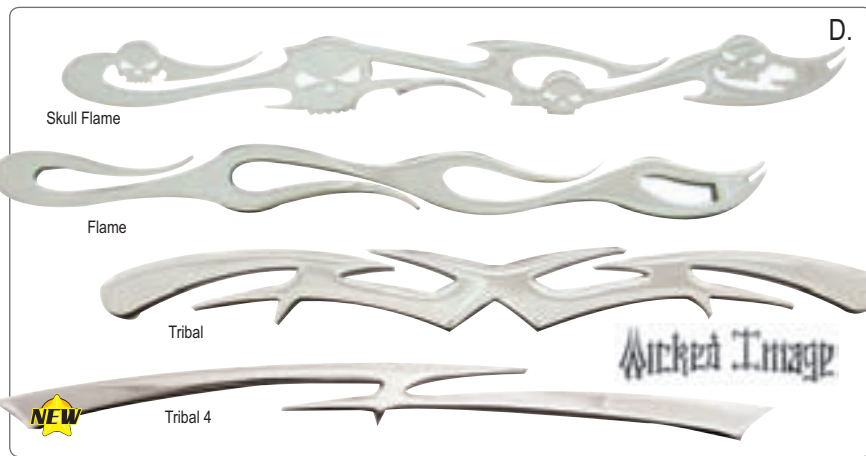

D. Wicked Image Shift Linkages

- Chromed billet aluminum construction
- Built to length for most H-D® models, call for complete list of fitments
- Feature built-in mounting hardware
- Made in the U.S.A.

PART	DESCRIPTION	MSRP
WZTF01	Skull Flame Linkage For All FX & '85-'98 FL, 12.25"	\$139.99
WZTF01TC	Skull Flame Linkage For '99-Later FL, 12.25"	\$139.99
WZTF01D	Skull Flame Linkage For Dyna® w/ Fwd Controls, 13.25"	\$139.99
WZFL01	Flame Shift Linkage For All FX & '85-'98 FL, 12.25"	\$139.99
WZFL01TC	Flame Shift Linkage For '99-Later FL, 12.25"	\$139.99
WZFL01D	Flame Shift Linkage For Dyna® w/ Fwd Controls, 13.25"	\$139.99
WZTL03	Tribal Shift Linkage For All FX & '85-'98 FL, 12.25"	\$139.99
WZTL03TC	Tribal Shift Linkage For '99-Later FL, 12.25"	\$139.99
WZTL03D	Tribal Shift Linkage For Dyna® w/ Fwd Controls, 13.25"	\$139.99
WZTL04TC	Tribal 4 Shift Linkage For '99-Later FXST & FL, 12.25"	\$139.99



E. Hell's Foundry Slotted Billet Shift Linkages For FL

- Billet aluminum ball-milled pattern shift linkage
- Fits all FL Touring models
- Complete with stainless steel threaded ends and installation instructions
- Polished to a high gloss and anodized for durability

PART	DESCRIPTION	MSRP
HFFLSLBA	Slotted Billet Shift Linkage, Blue Ano	\$89.95
HFFLSLCA	Slotted Billet Shift Linkage, Copper Ano	\$89.95
HFFLSLGA	Slotted Billet Shift Linkage, Gold Ano	\$89.95
HFFLSLPA	Slotted Billet Shift Linkage, Polished	\$89.95
HFFLSLPPA	Slotted Billet Shift Linkage, Purple Ano	\$89.95
HFFLSLRA	Slotted Billet Shift Linkage, Red Ano	\$89.95

A. Prowler® 6-Speed Transmissions For Softail®

- Completely forged shafts and gears made with 8720 Chrome Moly.
- Ground, crowned and back-cut close ratio gears as well as a roller shifter drum for smooth shifting
- Polished or black cases and chrome side & top covers

PART	DESCRIPTION	MSRP	PART	DESCRIPTION	MSRP
PRT6SP	LSD, Polished	\$1,333.00	PRT6SRP	RSD, Polished	1,999.00
PRT6SB	LSD, Black	\$1,333.00	PRT6SRB	RSD, Black	1,999.00

B. JIMS® 6-Speed RSD Transmissions

- The most innovative design, strength, quality and durability in the industry
- Covers are CNC'd billet aluminum then polished or chromed JIMS high standards
- Accept either hydraulic or cable clutch actuation
- A drop-in for most manufacturers' RSD frames with no frame mods required
- Installation in stock frames will require modifications

PART	DESCRIPTION	MSRP
JM8248	For '90-'99 Softail®, Black, Hydraulic	\$3,764.50
JM8249	For '90-'99 Softail®, Silver, Hydraulic	\$3,764.50
JM8250	For '90-'99 Softail®, Polished, Hydraulic	\$3,950.40
JM8251	For '90-'99 Softail®, Black, Hydraulic	\$3,764.50
JM8252	For '90-'99 Softail®, Silver, Hydraulic	\$3,764.50
JM8253	For '90-'99 Softail®, Polished, Hydraulic	\$3,950.40

C. JIMS® 6-Speed Transmissions For Twin Cam

- Roll at 75 MPH in 5th, then watch RPM's drop by almost 500 when shifting to 6th!
- All gears are standard width for performance and strength
- Includes chrome billet covers, trap door, bottled transmission oil and instructions
- JIMS uses an OEM case with wrinkle black finish
- Many fitments are available, call today!

PART	DESCRIPTION	MSRP
JM8112	6-Speed For '99-Later Softail, Wrinkle Black Case	\$3,363.75
JM1021	Transmission Master Rebuild Kit	\$214.10

D. JIMS® "Fat 5 Overdrive" Transmissions

- The strongest, toughest gearbox made — period
- Compact shifter increases the width and strength of every gear from 18% to 53%
- Shipped as a complete assembly installed in a case without pulley
- Mods may be needed for exhaust bracket, oil filler spout may be necessary
- Ask about "Fat 5 Overdrive" gearclusters for installation into an existing tranny

PART	DESCRIPTION	MSRP
JM8279	For '00-'06 FXST, Silver	\$3,448.45
JM8280	For '00-'06 FXST, Black	\$3,448.45
JM8282	For '90-'99 FXST, Silver	\$3,113.85
JM8283	For '90-'99 FXST, Black	\$3,113.85
JM8284	For '90-'99 FXST, Polished	\$3,299.75

E. JIMS® 6-Speed Super Kit (Gear Set)

Precision machined aerospace quality steel — ready to install without removing the tranny from your motorcycle.

JM8085	For '98-'99 BT and '99-'00 FLHT, FXD	MSRP: 2,137.85
JM8085L	For '00-Later TC Softail®/'01-Later FXD & FLHT	MSRP: \$2,195.05

F. S&S Cycle® Transmission Cases

5-Speed Basic Cases:		4- To 5-Speed Basic Cases:	
SS561075 Polished	MSRP \$599.95	SS561051 Natural	MSRP \$479.95
SS561050 Natural	\$349.95	4- To 5-Speed w/ Bearings & Seals:	
SS561071 Black	\$449.95	SS561038 Natural	\$549.95
5-Speed Cases w/ Bearings & Seals:		4- To 5-Speed Accessories:	
SS561076 Polished	\$669.95	SS574606 FL Batt. Box Bracket	\$32.45
SS561044 Natural	\$419.95	SS574756 FL Shift Linkage	\$104.95
SS561047 Black	\$519.95	SS574605 FX Batt. Box Bracket	\$29.95
SS561046 Starter Adapter Kit '86-'88	\$34.95	SS574750 FX Shift Linkage	\$99.95
		SS574604 FX Footpeg Mount	\$119.95
SS561027	Billet Trap Door Kit		\$205.95

A.

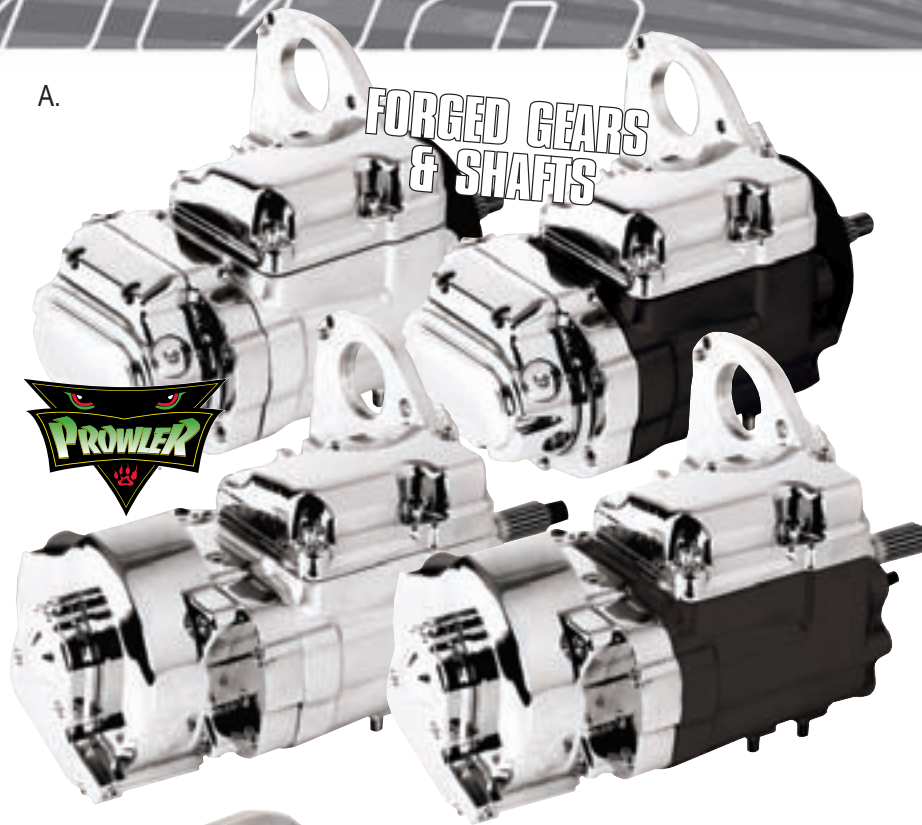

FORGED GEARS & SHAFTS

B.

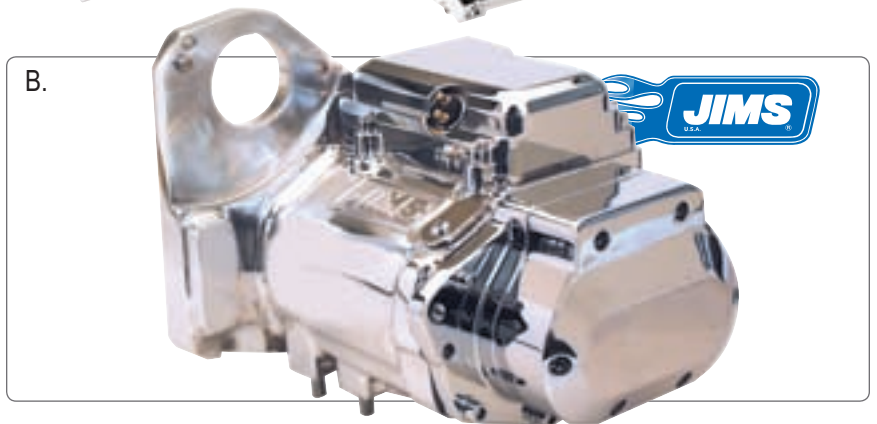

C.

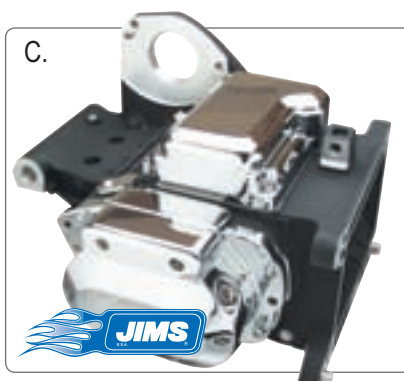

D.

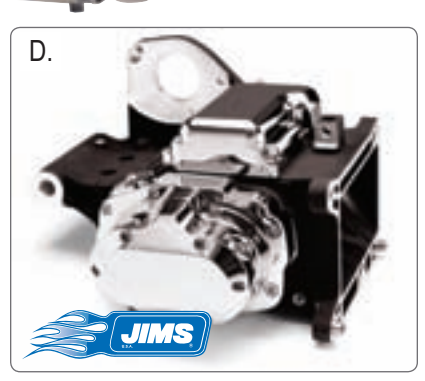

E.



F.



A. JIMS® Mega Nut Pulley Tightener

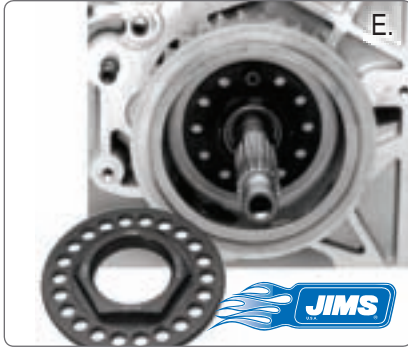

The Mega Nut is a certain cure for the loose pulley nut with its built-in lock plate. It can also be easily secured on aftermarket drives. Replaces OEM #35211-91.

JM1708 Mega Nut For '85-Later Belt Drive BT, Twin Cam 88®, JIMS® 6-Speed \$62.10

B. Stampede™ Clutch Slave Cylinder



STBHCSC100C Chrome	\$329.00
STBHCSC100P Polished	\$316.00
STBHCSC100B Black Ano	\$329.00

C. Bulletprüf® Primary Chains



- Durable, high-strength chains, manufactured for Bulletprüf® by Hitachi Maxco, one of the strongest chain manufacturers in the world
- Endless chain construction features truly cylindrical bushings
- Factory prestressed to ensure quality and precise fitment

PART	DESCRIPTION	MSRP
BP476	Primary Chain, 76 L, 2 Row, For FLT/Road King®	\$72.99
BP482	Primary Chain, 82 L, 2 Row, For Softail® & Dyna®	\$72.99
BP476	Primary Chain, 76 L, 2 Row, For FLT/Road King®	\$72.99
BP482	Primary Chain, 82 L, 2 Row, For Softail® & Dyna®	\$72.99

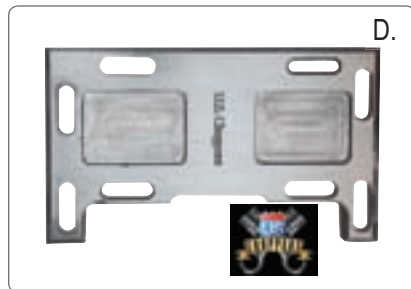

D. US Choppers Universal Tranny Mount Plate

- Allow a 4-speed box to fit in a 5- or 6-speed frame
- Allows up to 1" for a variety of rear tires and engine offsets
- The easy way to bolt a pre-Evolution® engine into an Evolution® frame

USCTMP Universal Tranny Mount Adapter Plate	\$79.00
---	---------

E. S&S® /GATES® High-Strength Final Drive Belts



- A series of secondary drive belts designed for many popular V-Twin models
- Super strong X3N carbon cord material which is significantly stronger than the Aramid material used in many OEM final drive belts

PART	DESCRIPTION	MSRP	PART	DESCRIPTION	MSRP
1.125" Wide 14mm Belts			1.5" Wide 14mm Belts		
SS1060357	125T	\$164.95	SS1060348	126T	\$174.95
SS1060358	128T	\$164.95	SS1060349	127T	\$174.95
SS1060359	130T	\$164.95	SS1060350	128T	\$174.95
SS1060360	132T	\$164.95	SS1060351	130T	\$174.95
SS1060361	133T	\$174.95	SS1060352	132T	\$174.95
SS1060362	135T	\$174.95	SS1060353	133T	\$177.95
SS1060363	139T	\$174.95	SS1060354	135T	\$179.95
			SS1060355	136T	\$179.95
			SS1060356	139T	\$184.95



F. Bulletprüf® Hydraulic Clutch Conversion Kit

- Easy-to-install conversion kit for cable-to-hydraulic clutch action
- Includes hand control, banjo bolts, transmission side cover, one-piece pushrod, bearing block, bleed screw (on top), gasket and chrome hardware
- Does not include brake/clutch lines
- Separate BPHCP pressure plate with sealed bearing is required for fitment with Bulletprüf® and Primo®

PART	DESCRIPTION	MSRP
Conversion Kits (Controls & Switches Sold Separately):		
BPCK144	Conversion Kit For 5- Or 6-Speed Evolution®	\$200.00
BPCK145	Conversion Kit For 5- Or 6-Speed TC	\$199.00
Controls (Switches Sold Separately):		
BP2135	Left/Right Controls For '05-Later, 9/16" Brake, 11/16", Clutch, MUST USE DOT4	\$399.99
BP2136	Left/Right Controls For '05-Later, 9/16" Brake, 11/16", Clutch, MUST USE DOT4	\$399.99
BP2131	L/R Controls, 9/16" Brake, 11/16", Clutch For '96-L'04, MUST USE DOT5	\$399.99
BP2132	L/R Controls, 11/16" Brake, 11/16", Clutch For '96-L'04, MUST USE DOT5	\$399.99
Switches:		
BP1032C	Bulletprüf® OEM Switches For '96-Later, Chrome	\$119.99
BP1036B	Bulletprüf® OEM Switches For '96-Later, Black	\$119.99
BPHCP	Pressure Plate For Bulletprüf® OR Primo Belt Drive	\$83.20

G. Bulletprüf® Primary & Final Drive Belts



Proven, durable belts that meet or exceed major manufacturers' quality standards. Stock use only.

PART	DESCRIPTION	MSRP
PRIMARY DRIVE BELT For:		
BP1381348K	1.75" x 8mm 138T Int. Belt, Kevlar® For TC/Evolution®	\$99.99
FINAL DRIVE BELTS, 14mm, FIBERGLASS For:		
BP128100	1", 128T	\$129.99
BP128118	1.125", 128T Final Drive Belt for XL	\$129.99
BP130118	1.125", 130T, '95-'99 Wide Tire Softail®	\$129.99
BP132118	1.125", 132T, '94-'99 Wide Tire Softail®	\$129.99
BP133118	1.125", 133T, '00-Later, Dyna®	\$129.99
BP135118	1.125", 135T, '00-Later Softail®	\$129.99
BP136118	1.125", 136T, '04-'06 883/883C XL & XL w/ 2" Stretched Swingarms	\$129.99
BP126112	1.5", 126T, '80-'86 4-Speed BT	\$149.99
BP127112	1.5", 127T, '89-'92 Softail® & Customs w/ 32T Front & 61T Rear	\$149.99
BP128112	1.5", 128T, '93-'99, Softail®	\$149.99
BP130112	1.5", 130T, '95-'99, Softail®	\$149.99
BP132112	1.5", 132T, '86-'92 & '94 Softail®	\$149.99
BP133112	1.5", 133T, '91-'99 Dyna® (All)	\$149.99
BP135112	1.5", 135T, '85-'96 FLT/FXR w/ 34T Frt/65T Rear	\$149.99
BP136112	1.5", 136T, '85-'96 BT (Not Softail® Or Dyna®)	\$149.99
BP139112	1.5", 139T '97-Later FLT/Baggers	\$159.99

A. Bulletpruf® Chain Drive Kits For Softail®

- Includes necessary parts including inner and outer covers, 9F/8S K-Clutch, 82L Chain Drive, 66/102T Ring Gear, one-piece chain tensioner, gaskets & hardware
- Complete your drive with Spyke® and Bulletpruf® electrical components including starter, charging system and starter jackshaft
- **Twin Cam kits do not include charging system**
- Hydraulic clutch conversion kits available, see previous page

PART	DESCRIPTION	MSRP
For '94-'97 Evolution® Softail®		
BP302	102T, 25:36 Sprocket, 82-Link SFT Chain	\$1,399.99
BP30294SPK	BP302 w/ Spyke® Electrics	\$2,149.99
BP30294BPK	BP302 w/ Bulletpruf® Electrics	\$1,899.99
BP303	66T, 24:37 Sprocket, Special 10T/9T Pinion Gear	\$1,399.99
BP30394SPK	BP303 w/ Spyke® Electrics	\$1,899.99
BP30394BPK	BP303 w/ Bulletpruf® Electrics	\$2,299.99
For '89-'93 Evolution® Softail®		
BP301	66T, 24:37 Sprocket, 82-Link SFT Chain	\$1,310.24
BP30190SPK	BP301 w/ Spyke® Electrics	\$2,149.99
BP30190BPK	BP301 w/ Bulletpruf® Electrics	\$1,799.99

B. Bulletpruf® Inner & Outer Chain/Belt Primary Covers

- **Matches OEM specs for cover fitment and perfect acceptance of the chain or belt drive** (belt drive requires replacement of main primary shaft bearing)
- Main primary shaft bearing not included
- Includes reinforcement ribbing, primary bearing, seals, bushings & retaining rings

PART	DESCRIPTION	MSRP
BP121	Outer Cover For 3-Hole, '89-94	\$215.00
BP122	Outer Cover For 3-Hole, '95-Later	\$215.00
BP120	Outer Cover For 5-Hole Universal	\$215.00
BP131	Inner Cover For '89-'93 Softail®	\$289.99
BP130	Inner Cover For '94-'04 Softail®	\$289.99
BP13D	Inner Cover For Dyna®	Call
BP301DC	3-Hole Smooth Derby Cover, Chrome	\$22.99
BP301NC	Inspection Cover, Chrome	\$11.99
BP301PG	Premium Primary Gasket	\$24.62

C. Bulletpruf® Chain Drive Primary Kit

- Includes standard compensating sprocket, complete high-quality K-Clutch assembly and 82-link chain for Softail®/Dyna® or 76-link chain for FLT
- Tensioner and clutch available separately

PART	KIT FOR SOFTAIL®:	MSRP	PART	KIT FOR FLT®:	MSRP
BP400	'90-'93, 66T/24-37/82	\$999.99	BP405	'90-'93, 66T/24-37/76	\$714.99
BP401	'94-'97, 102T/24-37/82	\$714.99	BP406	'94-'97, 102T/24-37/76	\$714.99
BP402*	'94-'97, 66T/24-37/82	\$714.99	BP407*	'94-'97, 66T/24-37/76	\$714.99
BP403	'98-'05, 102T/25-36/82	\$714.99	BP408	'98-'05, 102T/25-36/76	\$714.99
BP404	'98-'05, 66T/25-36/82	\$714.99	BP409	'98-'05, 66T/25-36/76	\$714.99
BP411	Complete Clutch Ass'y, (8-Steel, 9-Friction)	\$450.00		'90-'93	

*Needs special pinion gear 10T-9T for jackshaft.

D. Rivera Primary Chain Drive Kit With Clutch & Compensator

For FXR/FLT		
RE10460009	'90-'93 (24T Comp., 37T Clutch Basket, 66T Ring Gear)	\$1,059.81
RE10460012	'90-'93 (25T Comp., 36T Clutch Basket, 66T Ring Gear)	Call
RE10460010	'94-Later (25T Comp., 36T Clutch Basket, 102T Ring Gear)	\$1,086.22

For Softail® & Dyna®		
RE10460011	'90-'93 (25T Comp., 36T Clutch Basket, 66T Ring Gear)	Call
RE10460025	'90-'93 (24T Comp., 37T Clutch Basket, 102T Ring Gear)	Call
RE10460026	'90-'93 w/ 1" Offset (24T Comp., 37T Basket, 66T Ring)	Call
RE10460006	'90-'93 (24T Comp., 37T Clutch Basket, 66Tooth Ring Gear)	\$1,057.75
RE10460007	'94-Later (Incl. TC) (25T Comp., 36T Basket, 102T Ring)	\$999.95

E. Primo Brute III Extreme Enclosed Belt Drive Primary

- Easy install in very high torque and shock conditions from 150+ horsepower setups — lay down rubber!
- Durable 11mm 1 3/4" Super Belt, a state-of-the-art idler and the world famous Rivera Pro Clutch

PART	DESCRIPTION	MSRP
For Softail® & Dyna®		
PB20150055	'00-Later TC (Except '06 Dyna™)	\$909.71
PB20150051	'94-'99, 102T Ring Gear	\$902.96
PB20150053	'94-'99, 84T Ring/10T Pinion Gear	\$934.57
PB20150052	'90-'93, 84T Ring/10T Pinion Gear	\$734.57
PB20150050	'90-'93, 66T Ring Gear	\$847.28
PART	DESCRIPTION	MSRP
PB20150054	'90-'93, 66T Ring Gear w/ .5" Offset	\$861.29
PB20150056	'90-'93, 66T Ring Gear w/ 1.0" Offset	\$866.49
PB20150057	'90-'93, 66T Ring Gear w/ 1.5" Offset	\$876.97
PB20150060	'90-'93, 66T Ring Gear w/o Offset Insert & Starter Ring Gear, Requires Ordering Offset Insert, Nut, Washer, Screws & Ring Gear	\$779.66

A.

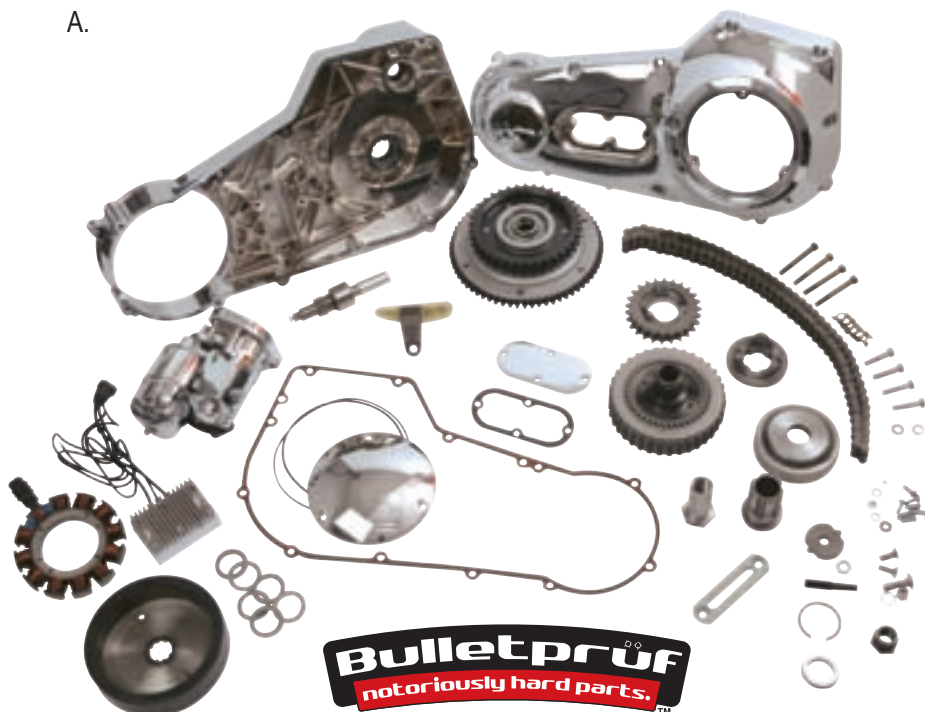

B.

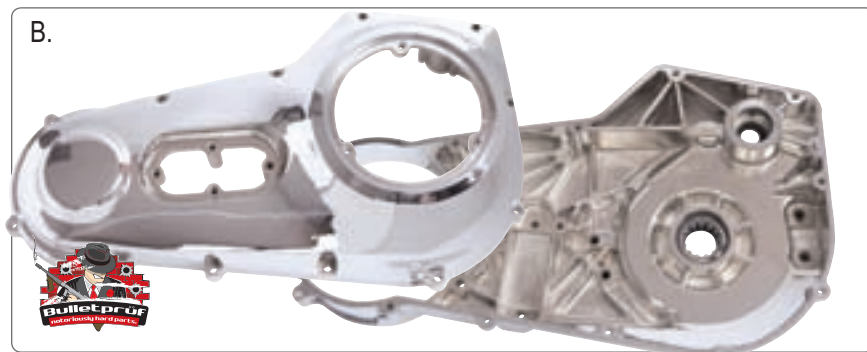

C.

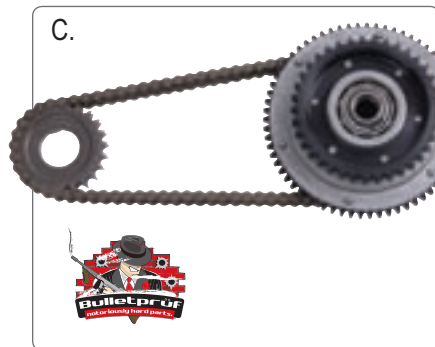

D.



E.

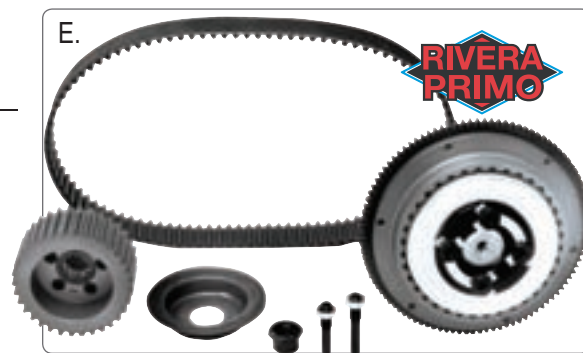



A.

A. Bulletprüf® Enclosed Primary Belt Drive Kits

- Includes inner and outer covers and mounting screws for '89-'93 Softail®
- For '94-later models, add the special 10T-9T pinion gear (BP400PG)
- The inner primary housing precisely fits a '01-later Twin Cam Softail®
- The included Kevlar® belts are fitted to a very high degree of accuracy
- For best fitment, we suggest using the Bulletprüf® outer cover — does not fit Dyna®

PART	DESCRIPTION	MSRP
BP4EBD	Primary Belt Drive Kit For '89-'93 Softail®	\$1,611.00
BP4PR	Pinion Gear For '94-Later Softail®	\$29.99

B. Bulletprüf® Enclosed Belt Primary Rebuild Kits (Not Shown)

- Includes clutch, front pulley and Kevlar® belt with the same specification as BP4 Kits above, minus the inner and outer primary covers

PART	DESCRIPTION	MSRP
BP4BRK	Rebuild Kit, '89-Later Softail®/Dyna®	Call

C. Bulletprüf® Belt Drive Fix/Jackshaft

- Stops starter grind associated with bikes with solid or rigid belt drive actuation
- For open belt drives with one-piece jackshafts
- The engineered spring and ramped teeth help integrate the teeth before the unit locks in and turns

PART	DESCRIPTION	MSRP
BPBDF	Belt Drive Fix (Excludes BDL Top Fuel)	\$79.99

D. Bulletprüf® Primary Spacer & Shaft Extension

Precisely machined in four increments for all Big Twins. Additional increments not shown here are available by special order.

PART	DESCRIPTION	MSRP
BP605	Spacer, 1"	\$139.99
BP607	Spacer, 1.5"	\$149.99
BP625	Extension/Nut, 1"	\$109.99
BP627	Extension/Nut, 1.5"	\$139.99

E. Primo Brute IV & V Direct Drive Kits

- A must-have for big-inch strokers that need more power for electric start
- Includes an integrated 78-tooth ring gear on the back side of the front pulley that allows the pinion gear to engage the starter ring gear
- Improved starter ratio to 54:1, an improvement of 96%!
- Includes chrome Monster Torque™ Starter

PART	DESCRIPTION	MSRP
PB20160051	Brute IV, 3", w/ 3D Flamed Cover	\$3,979.22
PB20160055	Brute IV, 3", w/ Billet Smooth Cover, Includes Pro Clutch	\$3,993.30
PB20160052	Brute V, 3.5" w/ 3D Flamed Cover	\$3,979.22
PB20160060	Brute V, 3.5" w/ Billet Smooth Cover, Includes Pro Clutch	\$3,993.30

F. Primo Brute IV Extreme Belt Drive Kits

- The Brute IV Extreme takes value to another degree
- 3", 8mm, electric start-compatible — designed for bolt-on component pieces
- Outer belt guard is 3/8" billet aluminum and features a stylish bolt-on derby cover
- Includes optional mounts for a center mount oil filter and mid-control shifting
- New starter nose assembly conceals the supplied jackshaft components
- Includes a re-designed Pro Clutch assembly for maximum torque transference

PART	DESCRIPTION	MSRP
PB20160101	Standard Offset	\$1,295.00
PB20160102	.500" Offset	\$1,384.53
PB20160103	1.00" Offset	\$1,391.68
PB20160104	1.50" Offset	\$1,405.98
PB20160105	1 7/16" Offset	\$1,405.98



C.



D.

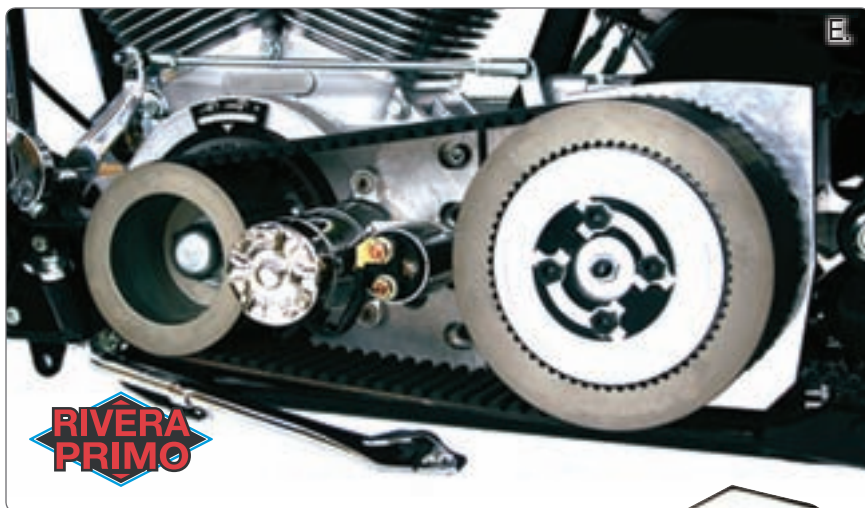

E.

RIVERA PRIMO



F.

RIVERA PRIMO

A. Primo Brute Force Belt Drives

- 3.5", 14mm belt drive with integrated polished outboard bearing support
- For '90-later H-D® Softail® or aftermarket rigids with late 5-speed transmissions
- Includes carbon fiber belt guards and integral outboard bearing support

PART	DESCRIPTION	MSRP
P20160042	Brute Force For '90-Later FXST/Aftermarket Rigids	3,763.00

B. Primo Brute IV Belt Drives

- Includes Pro-Clutch, starter support housing and starter jackshaft assembly as well as hardware and installation instructions
- Includes a two-piece motor plate in a full polished finish as well as a polished, ribbed aluminum outer belt guard

PART	DESCRIPTION	MSRP	PART	DESCRIPTION	MSRP
3" Belt Drives For '90-'99 Softail®			3" Belt Drive For '00-Later Softail®		
PB4EL90	Standard	\$2,085.67	PB4ELTC	Standard	\$1,882.40
PB4EL90P	Std., Polished	\$2,114.86	PB4ELTCP	Std., Polished	\$2,013.59
PB4EL90.1	1" Offset	\$1,899.52	PART DESCRIPTION MSRP		
PB4EL90.1P	1" Offset, Pol.	\$2,135.80	3" Belt Drive For '90-'99 Dyna™		
PB4EL90.5	0.5" Offset	\$2,182.89	PB4EL90D	Standard	Call
PB4EL90.5P	0.5" Offset, Pol.	\$2,182.89	PB4EL90DP	Std., Polished	\$2,120.77
PB4EL9015	1.5" Offset	Call			
PB4EL9015P	1.5" Offset, Pol.	\$2,171.79			

C. Primo Brute V Belt Drives

Brute 5's are 14mm, 3.5" open belt drives

PART	DESCRIPTION	MSRP
PB5ELTC	For '00-Later TC Softail®, Plain	Call
PB5ELTCP	For '00-Later TC Softail®, Polished	\$2,313.91
PB5EL90	For '90-'99 Evolution® Softail®, Plain	\$2,242.99
PB5EL90P	For '90-'99 Evolution® Softail®, Polished	\$2,503.38

D. Tauer Machine 3" Warlord Belt Drive

Combining American-made quality with a great value, the Warlord features:

- **Lower gear ratio for superior low end torque and easier starting**
- Billet front and rear pulleys for unsurpassed longevity
- Three-piece spring-loaded jackshaft for superior engagement with no grind
- Includes Alto USA Red Eagle high-performance clutch
- Pressure plate designed for quieter clutch engagement
- Rear pulley cover can be swapped for any standard five-point derby cover
- The clutch pack is located closer to the transmission, which minimizes transmission shaft flex
- Upgrade available to set up outer bearing support
- Includes seven fiber plates or nine-plate upgrade, available separately
- Increased clutch area by 20%

PART	DESCRIPTION	MSRP
TM7040000	Warlord Belt Drive For '90-'04 Softail®, Chrome	\$1,325.95
TM7020000	Warlord Belt Drive For '90-'04 Softail®, Wrinkle Black	\$1,299.00
TM7010000	Warlord Belt Drive For '90-'04 Softail®, Natural	\$1,099.00
TM7030000	Warlord Belt Drive For '90-'04 Softail®, Polished	\$1,199.00

E. Tauer Machine® Renegade & Warrior Belt Drives

- **TM® Renegade Belt Drives** are a complete high-performance 3" 8mm open primary drive available for electric start models (**excludes oil filter mount**)
- It has the highest standards, including starter gear and billet aluminum pulleys
- Includes reversible chrome engraved sword cover
- Nine Kevlar® clutch fibers, with increased surface contact in the clutch basket
- Upgrade to the patented Tauer Machine oil cooler covers shown in this section

- **The Warrior Belt Drive** has all the features of the Renegade drive in addition to a Twin Cam oil filter positioned in the backing plate.
- Tauer Machine® air scoops are machined in the plate, feeding air flow to the filter
- Filter holds more oil and aids in cooling the engine oil with more surface area
- Features all the components needed to put a 3" open primary drive on a Softail® with an electric start. Motor spacers may be needed and are sold separately. See Tauer's belt drive covers shown in this section

PART	DESCRIPTION	MSRP
TM1040000	Renegade Drive For LSD '90-'04 Softail®	\$1,799.00
TM4040000	Renegade Drive For RSD '90-'04 Softail®	\$1,799.00
TM1033215	Renegade Drive w/ Demonizer Cover, Polished	\$2,108.36
TM2040000	Warrior Drive For LSD '90-'04 Softail®	\$2,023.00
TM5040000	Warrior Drive For RSD '90-'04 Softail®	\$2,143.00

A.



B. - C.



D.



**2" WARLORD
NOW AVAILABLE**
Call For Details



E.

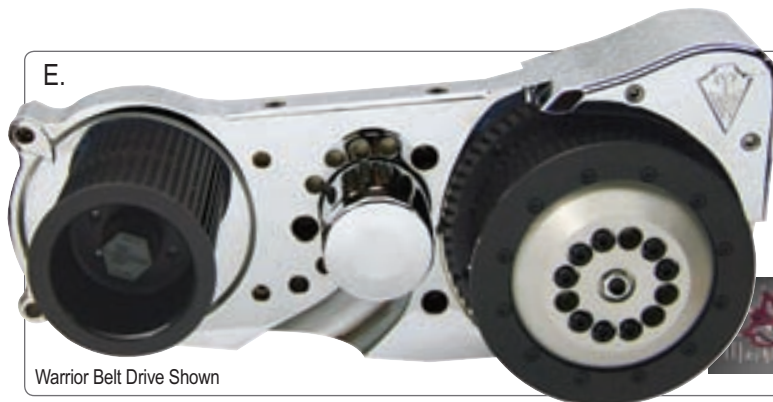

Warrior Belt Drive Shown





A. Primo Brute Slimline Belt Drives

- Slimline 1.75" 11mm narrow open belt drive kit
- Includes Kevlar® belt, pulleys, black motor plate and carbon fiber outer guard
- Fits '90-'06 Softail® & rigid customs with 12.812" center to center distance on primary drive
- Optional mid controls & center mount oil filter

PART	DESCRIPTION	MSRP
PB20160225	Slimline Belt Drive Kit For '90-'06 BT	\$2,299.95



B. Tauer Machine® Renegade Dual Belt Drives

- Doubled up on a Renegade drive – this new version has two 1.5" belts
 - The same great clutch, pulley and motor plate specs of the original
 - Avoid complete breakdowns in the event a belt breaks
 - Drive is much quieter over single belts while in operation
- See MCAdvantages.com For Complete Fitment Information



C. Prowler® Right Side Drive Hydraulic Clutch Actuator w/ Bearing Support

- Stop the strain on your clutch hand and wrist with this hydraulic clutch actuator that also has a much-needed internal shaft support with bearing for the RSD tranny
- With its internal hydraulic mechanism and the hose inlet tucked underneath, all lines have been erased yielding nothing but great looks
- Not only fits the Prowler® RSD tranny, but can provide its benefits to trannies by Baker™ and others

PART	DESCRIPTION	MSRP
PRT6BSC	Bearing Support/Hydraulic Actuator, Polished	\$569.99



D. GP Designs Main Shaft Outer Bearing Support

- Prevents crankshaft deflection and possible crankshaft bearing failure
- Fully secures crankshafts at their outermost point
- Unit bolts directly to engine case and the inner primary
- Effectively offers bottom-end longevity for stock to fully modified applications
- Includes all required hardware with installation instructions
- Fits '03-'06 FLH, with Softail® and Dyna® versions available soon
- Made in the USA

PART	DESCRIPTION	MSRP
GP151	Main Shaft Outer Bearing Support For Twin Cam	\$399.95



E. S&S Billet Primary Outer Cover

- Clean and sleek design that will complement the styling of any motorcycle from a near stocker to a wild one-off custom
- One small S&S logo is unobtrusively placed
- Bolts directly to stock or most aftermarket inner primary covers for added clutch clearance and an instant styling upgrade
- Entire S&S derby is removable, which allows unrestricted access to service or inspect the clutch
- The derby intended for street applications allows enough extra clearance for most aftermarket street clutches, such as the S&S high performance clutch, but is small enough that it does not present ground clearance problems on left turns
- The racing derby will accommodate the largest racing clutches, but by necessity is much larger and does restrict ground clearance — this style of derby is recommended only for racing
- Fitment for '89-'06 Softail® and '91-'05 Dyna® models

PART	DESCRIPTION	MSRP
SS564042	Street Derby Cover (Forward Controls)	\$1,185.95
SS564041	Race Derby Cover (Forward Controls)	\$1,395.95
SS564051	Street Derby Cover (Mid Controls)	\$1,215.95
SS564050	Race Derby Cover (Mid Controls)	\$1,425.95

Replacement Parts		
PART	DESCRIPTION	MSRP
SS564044	Street Derby Cover Only	\$449.95
SS564043	Race Derby Cover Only	\$565.95
SS564046	Inspection Cover Only (Forward Controls)	\$84.95
SS564045	Inspection Cover (Mid Controls)	\$99.95
SS564061	Seal Kit	\$27.95



A. Tauer Machine® Belt Drive Covers & Oil Coolers

- 2005 V-Twin Expo® Product Of The Year!
- Patent-pending oil cooler for today's big-inch motors
- Made from 6061-T6 billet aluminum
- Mounts to the outside of a TM®, BDL or Primo primary drive
- Delivers 25°-35° oil cooling completely concealed from view
- Oil cooler has a leak-free o-ring gasket system
- NOTE: BDL & Primo Drive fitment requires adapter below

PART	DESCRIPTION	MSRP
TMSW20C	3D Sword Oil Cooler For TM®, Chrome	\$1,344.00
TMTF4104	3D Sword Oil Cooler For BDL Top Fuel, Chrome	\$1,489.00
TMSW20P	3D Sword Oil Cooler For TM®, Polished	\$1,215.00
TMTF4103	3D Maltese Oil Cooler For BDL Top Fuel, Chrome	\$1,143.00
TMMA20C	3D Maltese Oil Cooler For TM®, Chrome	\$998.00
TMMA20P	3D Maltese Oil Cooler For TM®, Polished	\$894.00
TMBL20C	3D Blade Oil Cooler For TM®, Chrome	\$946.00
TMTF4101	3D Blade Oil Cooler For BDL Top Fuel, Chrome	\$1,091.00
TMBL20P	3D Blade Oil Cooler For TM®, Polished	\$842.00
TMBA20C	3D Battle Axe Oil Cooler For TM®, Chrome	\$946.00
TMTF4102	3D Battle Axe Oil Cooler For BDL Top Fuel, Chrome	\$1,091.00
TMBA20P	3D Battle Axe Oil Cooler For TM®, Polished	\$842.00
TM4100	Adapter For Primo Belt Drive	\$155.00

Covers Only - No Internal Oil Cooler

TMTF4204	3D Sword For BDL Top Fuel, Chrome	\$1,144.00
TMTF4203	3D Maltese Cross For BDL Top Fuel, Chrome	\$964.00
TMTF4202	3D Battle Axe For BDL Top Fuel, Chrome	\$938.00
TMTF4201	3D Blade For BDL Top Fuel, Chrome	\$938.00
TMSM15C	Engraved TM® Logo, Chrome	\$375.00
TMTG15C	Engraved Trucker Girl, Chrome (Not Shown)	\$375.00
TMMA15C	Engraved Maltese Cross, Chrome	\$436.00
TMBL15C	Engraved Blade, Chrome	\$449.00
TMBA15C	Engraved Battle Axe, Chrome	\$462.00
TMSW15C	Engraved TM® Sword, Chrome	\$553.00
TMTF4405	Smooth w/ Small TM® Logo, BDL Top Fuel, Chrome	\$520.00

B. Primo 3D Flamed Belt Guard

- Keeps foreign objects out of the belt drive and away from the pulleys
- Kit includes super-duty "H" bracket
- Recessed 3D details can be custom painted

PART	DESCRIPTION	MSRP
PB20140010	Fits Brute 4 Belt Drives	\$399.95
PB20140013	Fits Brute 5 Belt Drives	\$399.95

C. Tauer Machine® Demonizer Belt Drive Cover

- Combined with the Renegade belt drive, it's a great new look you've got to have
- Also fits Tauer Renegade/Warrior as well as BDL & Primo with adapter
- Available in polished, black or chrome finishes

PART	DESCRIPTION	MSRP
TMG1010C	Chrome	\$499.00
TMG1010P	Polished	\$399.99
TMG1010BW	Wrinkle Black	\$399.00
TM4200	Adapter For BDL & Primo®	\$155.00

D. CPI Banshie Primary Covers

- Give a wailin' and screamin' visual effect to any bike
- Deep, geometric designs and premium chrome
- Fit BDL Super Street and Top Fuel drives, Primo Brute III, IV and V

PART	DESCRIPTION	MSRP
CHPC501B	Tribal Banshie, 8mm BDL	\$441.00
CHPC501P	Tribal Banshie, Primo	\$441.00
CHPC505B	Short Tribal Banshie, BDL	\$441.00
CHPC505P	Short Tribal Banshie, Primo	\$441.00
CHPC503B	Top Fuel-Style Banshie, 3 3/8" BDL	\$495.10
CHPC512B	Top Fuel-Style Banshie, 8mm BDL	\$495.10
CHPC514P	Top Fuel-Style Banshie, Primo	\$495.10
CHPC502B	Flame Banshie, 8mm BDL	\$441.00
CHPC502P	Flame Banshie, Primo	\$441.00

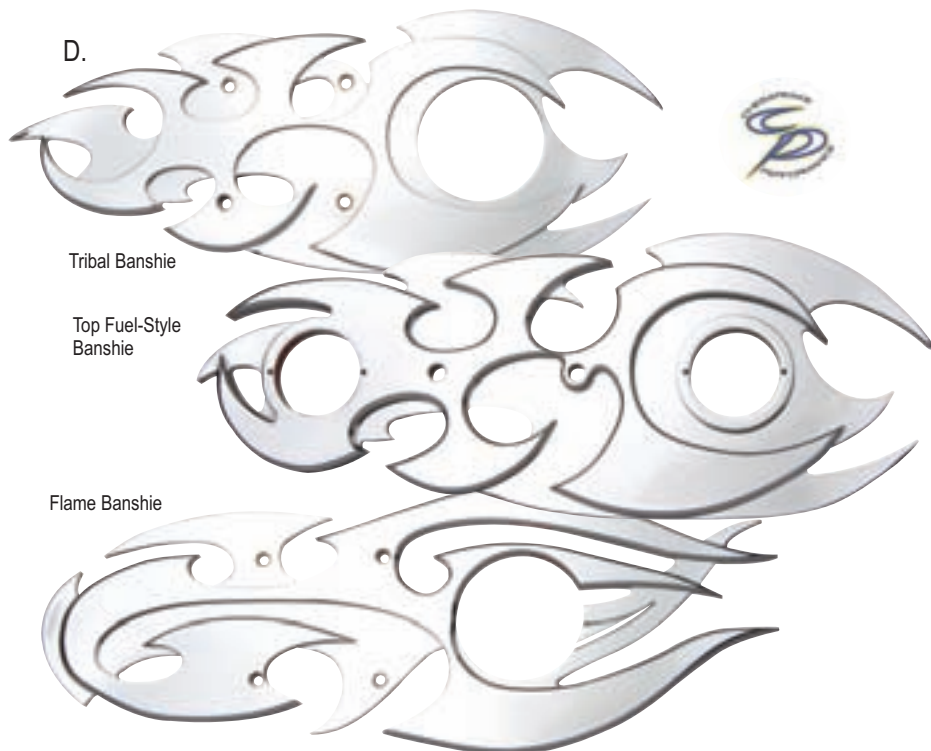
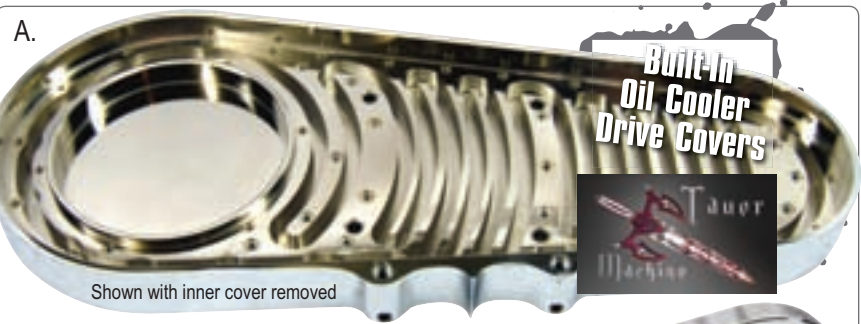



A.

A. Crime Scene Choppers "Bad Attitude" Belt Drive Cover

- Bolts right up to a 3" BDL drive with the motor plate
- Easily adapts to other belt drive systems with owner-fabricated mounts
- The space between the fins is open to see through to the pulleys
- Made of cast aluminum, cover is approx. 18" long by 10" tall, and mounts using standard 4-point mounts. Stainless hardware included
- The Crime Scene Torque Plate is used to mount BDL-style primary covers, including the Bad Attitude™ finned cover, in applications that do not use a primary plate. It greatly increases the rigidity of the primary drive in addition to providing mounts for the primary cover.

PART	DESCRIPTION	MSRP
CSC674	Polished	\$450.00
CSC675	Satin w/ Highlight Polished Fins	\$335.00
CSC678	Torque Plate For BDL	\$95.00
CSC812	Cover Adapter For Old Style Covers To Newer BDL Pattern	\$69.00



B.

B. Grandeur Cycle® Belt Drive Primary Covers

- Precision machined of 1/2" thick solid chrome billet

PART	DESCRIPTION	MSRP
GRCAPC1	Slot Machine Cover For Primo & Early BDL	\$350.00
GRCAPC1L	Slot Machine Cover For Late BDL	\$350.00
GRCAPC2	Hot Slot Cover For Primo & Early BDL	\$350.00
GRCAPC2L	Hot Slot Cover For Late BDL	\$350.00



C.



D.

C. Primo Belt Drive Covers

Billet aluminum guards with mounting hardware for Softail®, Dyna® and FXR. Available natural, polished or chromed.

PART	DESCRIPTION	MSRP	PART	DESCRIPTION	MSRP
Smooth Cover For Softail®/Dyna®:			Slotted Cover For Softail®/Dyna®:		
PP411B	Natural	\$162.50	PP411PAY	Polished	Call
PP411BP	Polished	\$187.87	PP411CAY	Chrome	Call
PP411BC	Chrome	\$194.56	Slotted Cover For FXR:		
Smooth Cover For FXR:			PP611PAY	Polished	Call
PP611B	FXR, Natural	\$162.50	PP611CAY	Chrome	Call
PP611BP	FXR, Polished	\$178.00			
PP611BC	FXR, Chrome	\$190.00			

D. Primo Open Belt Drive Surrounds

Primo's belt surrounds have a gleaming chrome finish for their line of belt drives.

PART	DESCRIPTION	MSRP
PP1012CAY	Flamed Half Guard For Brute IV, Chrome	\$347.35
PP1012PAY	Flamed Half Guard For Brute IV, Polished	\$347.82
PP1011CAY	Flamed Half Guard For Brute V, Chrome	\$318.78
PP1011PAY	Flamed Half Guard For Brute V, Polished	\$295.79
PP811CAY	Half Guard For Brute IV, Chrome	\$269.98
PP811PAY	Half Guard For Brute IV, Polished	\$215.00
PP812CAY	Half Guard For Brute V, Chrome	\$361.43
PP812PAY	Half Guard For Brute V, Polished	\$334.22
PP911CAY	Guard For Brute V, Chrome	\$315.00
PP911PAY	Guard For Brute V, Polished	Call



E.

E. Grandeur Cycle® Split Belt Guard

Rather not catch your pants in an open belt drive, but you love the freedom and looks of the open belt? **Check out this belt guard, it fits any open belt drive.**

PART	DESCRIPTION	MSRP
GRR511	Split Belt Guard, Chrome	\$174.95
GRRB511	Split Belt Guard, Black	\$174.95



F.

F. Detroit Bros.® Open Primary Belt Guard

A great-looking, CNC-machined billet aluminum guard assembly with stainless steel hardware. It keeps moving belts behind bars. Fits '86-'05 Softail® with 3" and 3 3/8" Belt Drives including BDL. USA Made.

PART	DESCRIPTION	MSRP
DBPG1	Primary Guard, '86-'05 Softail®, Polished	\$199.50

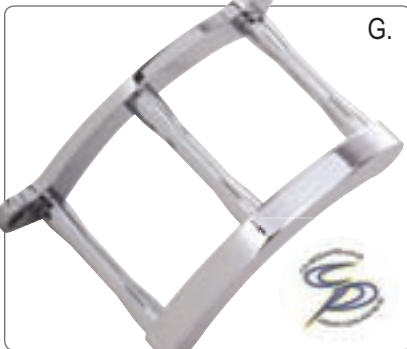

G.

G. CPI Top Fuel Open Drive Belt Guard

- Fits most open primary drive systems
- Bolts up to the inner primary plate using the bolts for the inner primary

PART	DESCRIPTION	MSRP
CHBG502	Top Fuel Belt Guard, Chrome	\$181.90



**BLACK/CUT
NOW AVAILABLE
FOR ALL STYLES!**

D. Forge-Tec Billet Wheels

- Rotary forged through a proprietary process using aircraft grade 6061 billet, then lathed and milled using state of the art equipment
- This process makes use of the radial grain structure of the 6061 aluminum to produce a wheel of unmatched strength
- Polished, chrome or black powdercoat
- Matching rotors, pulleys and sprockets are also available, see MCAvantages.com
- Fitments for 1", .75", 22mm & Big Dog® axles
- Available wheel sizes include:

16 x 3.5	18" x 3.5"	18" x 8.5"	18" x 13"	20" x 10.5"	23" x 3.5"
17" x 6.25"	18" x 4.25"	18" x 10"	19" x 2.15"	21" x 2.15"	
17" x 12"	18" x 5.5"	18" x 10.5"	19" x 3"	21" x 3.5"	



NEW

Creations 7, Black



Creations 3



Monarch



Scalpel



Engage



Creations 5



Nomad



Deviate



Demon



Creations 7



Legacy



Peyote



Ruckus



Warrior



B. Metal Motorsport

- Designed as rolling works of art for elite bikes
- Forged, machined, then plated with gleaming chrome, they are crafted to the very edge of the rim
- Matching pulleys, rotors and driveside brackets also available, see MCAdvantages.com
- Available wheel sizes include:

17" x 12"	18" x 3.5"	18" x 8.5"	21" x 3"	24" x 4"
18" x 10.5"	18" x 4.25"	20" x 10.5"	21" x 9"	26" x 3.5"
18" x 14"	18" x 5.5"	21" x 2.15"	23" x 4"	

**AVAILABLE IN
 POLISHED OR
 CHROME!**



Nitrous Thrust



Big Homie



SnM



Trippin'



Lusso



Barb



X-Wang



Don Juan



Tire Not
 Included

Cutlass



Cypher



Devil's Slide



Felon



A. Stampede™ Billet Wheels, Pulleys, Rotors & Sprockets

- Made entirely in the U.S.A. with state-of-the-art CNC machined billet or forged construction
- Their precision machining guarantees absolute trueness in every wheel
- Complete with factory-set bearing tolerances, seals, chrome hardware and valve stem
- Call MC Advantages for custom pricing
- Pulleys and rotors are on the next page — fitments available as:

16" x 3" Cast Wheels	18" x 5.5" Forged Wheels	19" x 2.15" Forged Wheels
16" x 3.5" Forged Wheels	18" x 8.5" Cast Wheels	21" x 2.15" Cast Wheels
16" x 5.5" Forged Wheels	18" x 8.5" Forged Wheels	21" x 2.15" Forged Wheels
18" x 3.5" Cast Wheels	18" x 10.25" Cast Wheels	21" x 3.25" Cast Wheels
18" x 3.5" Forged Wheels	18" x 10.5" Forged Wheels	21" x 3.25" Forged Wheels
18" x 5.5" Cast Wheels	19" x 2.15" Cast Wheels	



Maltese



Black Jack



Tri-Blade



Thome



Split 5



Riff



Walking Star

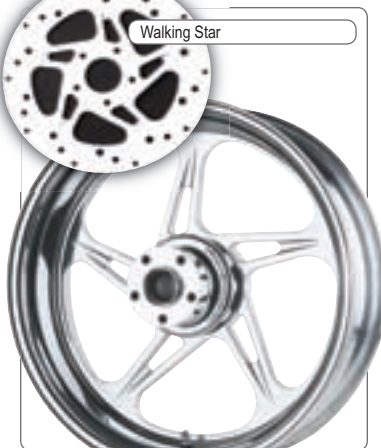

6-D

Dual-Step



Dark Daze

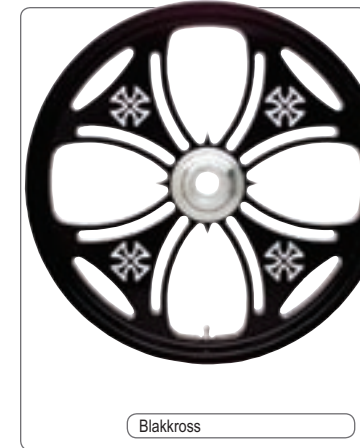

Hard Time

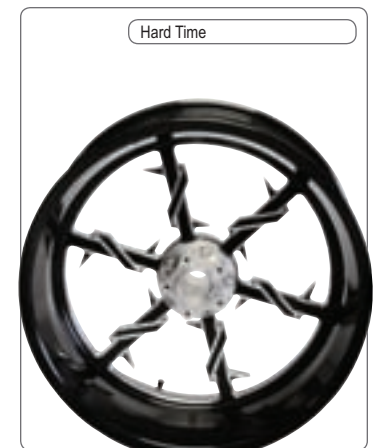

Wagon

Blakkross

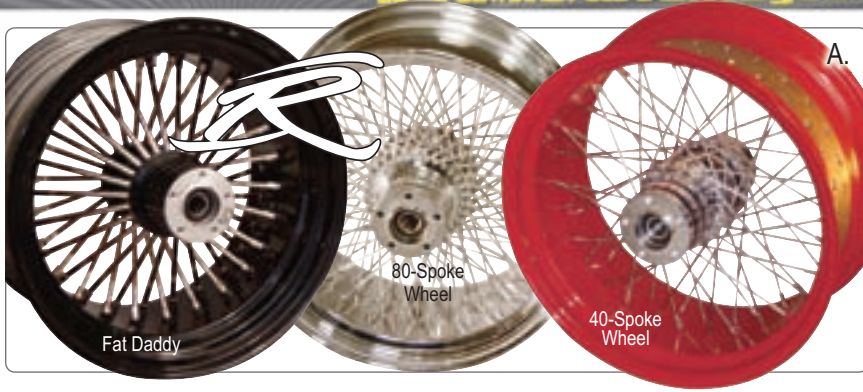

A. Ride Wright Spoked Wheels

- High-quality, classic spoked wheels, rotors and pulleys
 - Built with the best in new and time-tested technologies
 - All wheel rims are spun for trueness in the circumference of the wheel
 - Available with 1/8" standard, twisted, diamond or 3/8" Fat Daddy spokes
 - Multiple colors and powdercoats available for the rims, hubs and spokes including chrome, polished, fire engine red, pumpkin yellow, cobalt blue, canary yellow, jet black, neon green and many more with or without metal flake—by special order
 - All spoked wheels are available in 40, 50, 60 and 80-spoke configurations
 - Available in sizes 16" x 3.5" to 21" x 3.5" and as wide as 18" x 14". Direct replacement hubs and 16" OR 18" x 5.5" wheels available for '06 Dyna®
 - Setup also available for pre-'66 brakeless models
 - Spokes are made from stainless steel to extend life and prevent corrosion — this also forgives the "pulse" often associated with the driveline of V-Twins
 - Hubs are billet cut for durability and precision
- Call For Custom Fitment Information



B. Stampede™ Rotors & Pulleys

- Stampede's Rotors & Pulleys can match their corresponding wheel
- Rotors are constructed from 420 stainless steel
- Heat treated to spec and blanchered ground for perfect flatness
- Precision machining guarantees absolute trueness in every item
- See previous page for matching wheel styles
- Call MC Advantages for a custom quote

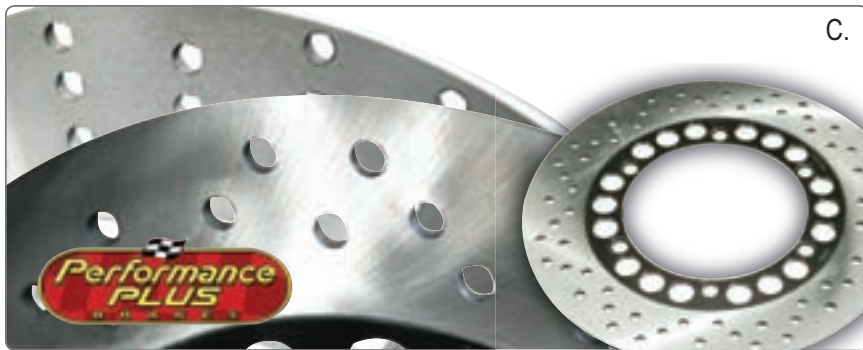

C. Performance Plus Rotors

- Excellent fit and finish
 - A line of rotors from the same people who make our outstanding brake pads
- See MCAdvantages.com For Complete H-D® and Metric Fitments

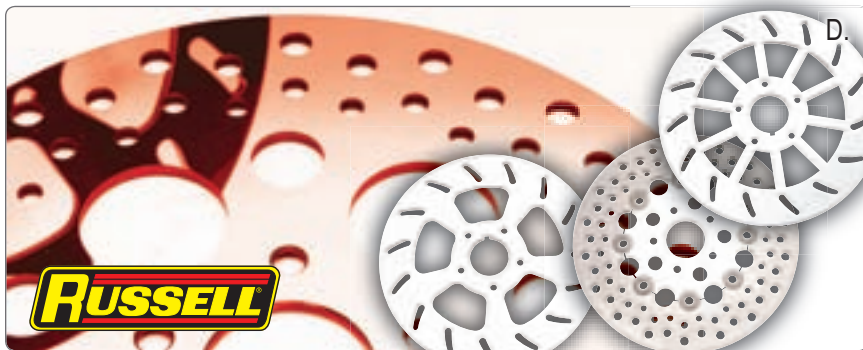

D. Russell® Performance Rotors

- Exclusive E.F.S. mirror finishing
 - Held to exacting specifications with near perfect flatness and surface finish
 - 5-spoke and Turbine designs are precision cut from rust-resistant SVS420JZ stainless steel utilizing the latest high-pressure water jet technology
 - This process eliminates metal heat distortion while maintaining metal integrity
 - Unique hole patterns deliver the optimum in heat dissipation, providing the maximum in braking efficiency
- See MCAdvantages.com For Complete Fitment Information

E. Gary's Greaser Tool For Wheel Bearings

Grease wheel bearings without removing the bearing and destroying the grease seal. Remove wheel and spacers, insert tool then pack bearing with grease gun. In no time, the job is done!

PART	DESCRIPTION	MSRP
GGT	Gary's Wheel Bearing Greaser Tool	\$36.95

F. Doherty Wheel Spacers

Doherty premium wheel spacer kits are packaged in kits of 23 or 54 spacers which include labeling showing replacement part numbers. Replacement spacers are available in packages of 4.

PART	DESCRIPTION	MSRP
DH7500	Universal Spacer Kit, 3/4" I.D., 54 Spacers	\$214.95
DH7502	Universal Spacer Kit, 3/4" I.D., 23 Spacers	\$121.95
DH7501	Universal Spacer Kit, 1" I.D., 54 Spacers	\$218.95
DH7503	Universal Spacer Kit, 1" I.D., 23 Spacers	\$124.95
DH7504	Combination Spacer Kit, 3/4" & 1" I.D., 54 Spacers	\$239.95

Wheel Spacer 4-Packs See Price Sheet





Duro Tires Boulevard Tire Line

- Manufactured using the highest quality natural and synthetic rubber
- Offers excellent puncture resistance and long life

PART	DESCRIPTION	MSRP
DU25296C15140	140/90H-15 76 T/L	\$81.70
DU25296C15150	150/90H-15 79 T/L	\$102.20
DU25296C15170	170/80H-15 83 T/L	\$89.36
DU25296C16130	130/90H-16 73 T/L	\$86.02
DU25296C16160	160/80H-16 75 T/L	\$117.96
DU25296A16130	130/90H-16 67 T/L	\$91.78
DU25296A18130	130/70H-18 63 T/L	\$69.89
DU25296A19100	100/90H-19 57 T/L	\$62.13
DU25296A19110	110/90H-19 62 T/L	\$65.11
DU25296A2180	80/90H-21 56 T/L	\$54.91



Duro Tires Excursion Tire Line

- Manufactured using the highest quality natural and synthetic rubber
- Offers excellent puncture resistance and long life

PART	DESCRIPTION	MSRP
DU2526116120	120/90H-16 63 T/L	\$74.02
DU2526116130	130/90H-16 67 T/L	\$76.42
DU2526116140	140/90H-16 71 T/L	\$85.53
DU2526117120	120/90H-17 64 T/L	\$63.80
DU2526117130	130/90H-17 68 T/L	\$78.13
DU2526118100	100-90H-18 56 T/L	\$61.56
DU2526118110	110/90H-18 61 T/L	\$68.98
DU2526119120	120/90H-18 65 T/L	\$77.20
DU2526119100	100/90H-19 57 T/L	\$64.76



Duro Tires HF-918 Front Tires

- Manufactured using the highest quality natural and synthetic rubber
- Offers excellent puncture resistance and long life

PART	DESCRIPTION	MSRP
DU2591816100	100/90-16 T/L	\$57.73
DU2591816120	120/80-16 T/L	\$70.87
DU2591817110	110/70-17 T/L	\$52.58
DU259181890	90/90-18 T/L	\$54.44
DU2591818100	100/90-18 T/L	\$62.24
DU2591819100	100/90-19 T/L	\$63.58



Duro Tires HF-918 Rear Tires

- Manufactured using the highest quality natural and synthetic rubber
- Offers excellent puncture resistance and long life

PART	DESCRIPTION	MSRP
DU2591817130	130/90-17 T/L	\$96.89
DU2591817140	140/70-17 T/L	\$72.84
DU2591818110	110/90-18 T/L	\$68.67
DU2591818120	120/90-18 T/L	\$84.69
DU2591818130	130/80-18 T/L	\$86.02
DU2591818140	140/70-18 T/L	\$93.83



Duro Tires HF-302 Series Tires

- Manufactured using the highest quality natural and synthetic rubber
- Offers excellent puncture resistance and long life

PART	DESCRIPTION	MSRP
DU2530216510	5.10-16 TT	\$84.02



Duro Tires HF-314 Series Tires

- Manufactured using the highest quality natural and synthetic rubber
- Offers excellent puncture resistance and long life

PART	DESCRIPTION	MSRP
DU2531418350	3.50S-18 TT	\$46.56



Duro Tires HF-317 Series Tires

- Manufactured using the highest quality natural and synthetic rubber
- Offers excellent puncture resistance and long life

PART	DESCRIPTION	MSRP
DU2531718300	3.00S-18 TT	\$39.56
DU2531719325	3.25H-19 TT	\$44.58

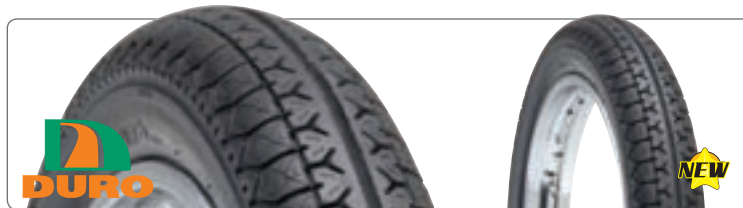

Duro Tires HF-318 Series Tires

- Manufactured using the highest quality natural and synthetic rubber
- Offers excellent puncture resistance and long life

PART	DESCRIPTION	MSRP
	4.00H-18 TT	\$49.03

A. Performance Plus Brake Pads

- Quality materials and construction can keep wheels 80% cleaner versus stock.
- Extend the life of rotors while providing more bite and shorter stopping distances in all conditions.
- **As a noise-free braking system, these pads have been extensively dynamometer and fleet tested.**
- The 100% asbestos-free formula is manufactured from man-made Aramid fibers including Kevlar® and Twaron®.
- These pads feature a LIFETIME WARRANTY, guaranteed for life against materials and workmanship defects. Non-transferable warranty does not cover race or track use. **Qualifying initial orders receive a FREE spinner rack. Call for details.**

See Price List For More Fitment Information SINTERED = S ORGANIC = O

Brake Pad Fitments For:		Sintered	Organic
PLHD6008S/O	FL/FLH, '72-'84 (Banana Caliper), Front	N/A	\$23.40
PLHD6009S/O	FLHR/FLHRCI, '94-'99, Front	\$35.10	\$25.20
PLHD6010S/O	FLHR/FLHRCI, '94-'99, Rear	\$35.10	\$29.70
PLHD6013S/O	FLHRCI, '00-'04, Front Uses 2 Set, Front/Rear Same	\$29.70	\$25.20
PLP8053S/O	FLHRCI, '05-'06, Front Uses 2 Set, Front/Rear Same	\$27.00	\$25.20
PLP8053S/O	FLHRi / FLHR, '05-'06, Front Uses 2 Set, Front/Rear Same	\$27.00	\$25.20
PLHD6013S/O	FLHRI/FLHR '00-'04, Front Uses 2 Set, Front/Rear Same	\$29.70	\$25.20
PLP8053S/O	FLHRS / FLHRI, '05-'06, Front Uses 2 Set, Front/Rear Same	\$27.00	\$25.20
PLHD6013S/O	FLHSR/FLHSRI '04, Front Uses 2 Set, Front/Rear Same	\$29.70	\$25.20
PLHD6013S/O	FLHT/FLHTI, '00-'04	\$29.70	\$25.20
PLP8053S/O	FLHTC / FLHTCI, '05-'06, Front Uses 2 Set, Front/Rear Same	\$27.00	\$25.20
PLHD6013S/O	FLHTC/FLHTCI, '04, Front Uses 2 Set, Front/Rear Same	\$29.70	\$25.20
PLHD6013S/O	FLHTC/FLHTCI, '04, Front Uses 2 Set, Front/Rear Same	\$29.70	\$25.20
PLP8053S/O	FLHTC/FLHTCI, '04, Front Uses 2 Set, Front/Rear Same	\$27.00	\$25.20
PLP8053S/O	FLHX / FLHXi Street Glide®, '06, Front Uses 2 Set, Front/Rear Same	\$27.00	\$25.20
PLHD6013S/O	FLSTCI/FLSTC, '00-'04	\$29.70	\$25.20
PLHD6013S/O	FLSTF/FLSTFI '00-'04	\$29.70	\$25.20
PLP8053S/O	FLTR / FKTRI, '05-'06, Front Uses 2 Set, Front/Rear Same	\$27.00	\$25.20
PLHD6013S/O	FLTR/FLTRI, '00-'04, Front Uses 2 Set, Front/Rear Same	\$29.70	\$25.20
PLHD6013S/O	FXD, '00-'03, Front Uses 2 Set, Front/Rear Same	\$29.70	\$25.20
PLHD6013S/O	FXD, '00-'03, Front/Rear Same	\$29.70	\$25.20
PLP8053S/O	FXDBi Street Bob®, '06, Front/Rear Same	\$27.00	\$25.20
PLP8053S/O	FXDC/FXDCi Super Glide® Custom, '05, Front/Rear Same	\$27.00	\$25.20
PLP8053S/O	FXDCi Dyna® Super Glide® Custom, '06, Front/Rear Same	\$27.00	\$25.20
PLP8053S/O	FXDi Super Glide® 1450, '05, Front/Rear Same	\$27.00	\$25.20
PLHD6013S/O	FXDI, '05	\$29.70	\$25.20
PLP8053S/O	FXDLi Low Rider® 1450, '04-'05, Front/Rear Same	\$27.00	\$25.20
PLP8053S/O	FXDLi Low Rider® 1450, '06, Front/Rear Same	\$27.00	\$25.20
PLHD6013S/O	FXDLI, '05	\$29.70	\$25.20
PLHD6013S/O	FXDS Convertible, '00-'02, Requires 2 Sets	\$29.70	\$25.20
PLHD6013S/O	FXDWG, '00-'03, Front Uses 2 Set, Front/Rear Same	\$29.70	\$25.20
PLP8053S/O	FXDWGi Dyna® Wide Glide, '06, Front/Rear Same	\$27.00	\$25.20
PLP8053S/O	FXDWGi Wide Glide® 1450, '05, Front/Rear Same	\$27.00	\$25.20
PLHD6013S/O	FXDWGI Wide Glide®, '05	\$29.70	\$25.20
PLHD6013S/O	FXDX, '00-'03, Front Uses 2 Set, Front/Rear Same	\$29.70	\$25.20
PLHD6013S/O	FXDXI, '04, Front Uses 2 Set, Front/Rear Same	\$29.70	\$25.20
PLHD6013S/O	FXDXT '01-'03, Front Uses 2 Set, Front/Rear Same	\$29.70	\$25.20
PLHD6009S/O	FXST/B/S & FLST/C/F/S/N, '84-'99 Front Only	\$35.10	\$25.20
PLHD6004S/O	FXST/B/S & FLST/C/F/S/N, '84-E'87 Rear	\$27.90	\$25.20
PLHD6011S/O	FXST/B/S & FLST/C/F/S/N, L'87-'99 Rear	\$27.90	\$25.20
PLP8053S/O	FXST/FXSTI, '05-'06, Front/Rear Same	\$27.00	\$25.20
PLHD6013S/O	FXST/FXSTI, '00-'04	\$29.70	\$25.20
PLP8053S/O	FXSTB/FXSTBi Night Train®, '05-'06, Front/Rear Same	\$27.00	\$25.20
PLP8053S/O	FXSTDI/FXSTDi Softail Deuce/i, '05-'06, Front/Rear Same	\$27.00	\$25.20
PLHD6009S/O	FXSTS/FXFTSI Springer®, '05-'06, Front	\$35.10	\$25.20
PLP8053S/O	FXSTS/FXFTSI Springer®, '05-'06, Rear	\$27.00	\$25.20
PLHD6009S/O	FXSTS/FXSTSI Springer®, '00-'04, Front	\$35.10	\$25.20
PLHD6013S/O	FXSTS/FXSTSI Springer®, '00-'04, Rear	\$29.70	\$25.20
PLHD6013S/O	V-Rod '00-'04 Note: '02-'04, Front Uses 2 Set, Front/Rear Same	\$29.70	\$25.20
PLHD6013S/O	XL1200C, '00-'03, Front/Rear Same	\$29.70	\$25.20
PLHD6013S/O	XL1200S, '00-'03, Front Uses 2 Set, Front/Rear Same	\$29.70	\$25.20
PLHD6014S/O	XL 883/C/L/R, Front	\$45.90	\$43.20
PLHD6015S/O	XL 883/C/L/R, Rear	\$45.90	\$43.20
PLHD6014S/O	XL 1200, '04-'06, Front	\$45.90	\$43.20
PLHD6015S/O	XL 1200, '04-'06, Rear	\$45.90	\$43.20
PLHD6013S/O	XL883 Hugger, '00-'03, Front/Rear Same	\$29.70	\$25.20
PLHD6013S/O	XLH883/C/R, '00-'03, Front/Rear Same	\$29.70	\$25.20
VICTORY®			
PLY2042S/O	All Victory, '98-'06, Front	\$35.10	\$27.90
PLD7061S/O	All Victory, '98-'06, Rear	\$35.10	\$27.90





A. Hawg Halters Sprocket Brake Kits

- Includes 4-piston caliper with integral mount for 1" axle, mounting tab and bolt
- Heat treated, ground and black sprocket with mounting hardware
- .75" axle bushing included

PART	DESCRIPTION	MSRP
HHRKSBL351C	Left Side, 51T Sprocket, 1" Axle, Chrome	\$745.00
HHRKSBL351P	Left Side, 51T Sprocket, 1" Axle, Polished	\$698.00
HHRKSBL351B	Left Side, 51T Sprocket, 1" Axle, Black	\$698.00
HHRKSBR351C	Right Side, 51T Sprocket, 1" Axle, Chrome	\$745.00
HHRKSBR351P	Right Side, 51T Sprocket, 1" Axle, Polished	\$698.00
HHRKSBR351B	Right Side, 51T Sprocket, 1" Axle, Black	\$698.00
HHRKSBL351BB	Left Side, 51T Blank Sprocket, 1" Axle, Black	\$606.00
HHRKSBL351BC	Left Side, 51T Blank Sprocket, 1" Axle, Chrome	\$653.00
HHRKSBL351BP	Left Side, 51T Blank Sprocket, 1" Axle, Polished	\$606.00
HHRKSBR351BB	Right Side, 51T Blank Sprocket, 1" Axle, Black	\$606.00
HHRKSBR351BC	Right Side, 51T Blank Sprocket, 1" Axle, Chrome	\$653.00
HHRKSBR351BP	Right Side, 51T Blank Sprocket, 1" Axle, Polished	\$606.00
HH351001	Replacement Brake Pad	\$45.00
HH351002	Rebuild Kit	\$20.00

D. American Suspension Padlock Brakes/Sprocket Brake

Add a mean looking brake caliper to your bad front end! Brake kit includes twin piston caliper, stainless steel heat treated rotor, concealed banjo fitting and concealed bleeder. It supports right- or left-side drive mounting direct to the frame with the semi-concealed mounting bolt.

PART	DESCRIPTION	MSRP
ASPBCL	Padlock Brake Caliper, Left Front, Chrome	\$399.00
ASPBCL	Padlock Brake Caliper, Right Front, Chrome	\$399.00
ASP11SCO	Sprotor, Chrome	\$799.00
ASP11SRO	Sprotor, Raw	\$599.00
	Replacement Brake Pads	Call
ASPBK	Padlock Brake Rebuild Kit	\$79.00

B. Hawg Halters Driveside In-Board Brake System

- The latest addition to the HHI product line
- When spending big money on custom wheels, why not show them off?
- Designed to locate the brake caliper and rotor behind the drive pulley or sprocket providing an uncluttered view of your cool new wheels
- Applications include 18" x 5.5" and wider billet wheels and 18" x 8" and up spoke wheels, left or right side drive, belt or chain drive — call for other fitments
- An offset rotor system is available to fit most any stock or custom wheel available
- Adapt a wheel without an inboard rotor or convert a conventional wheel to the driveside brake set up
- Tag/license plate available separately

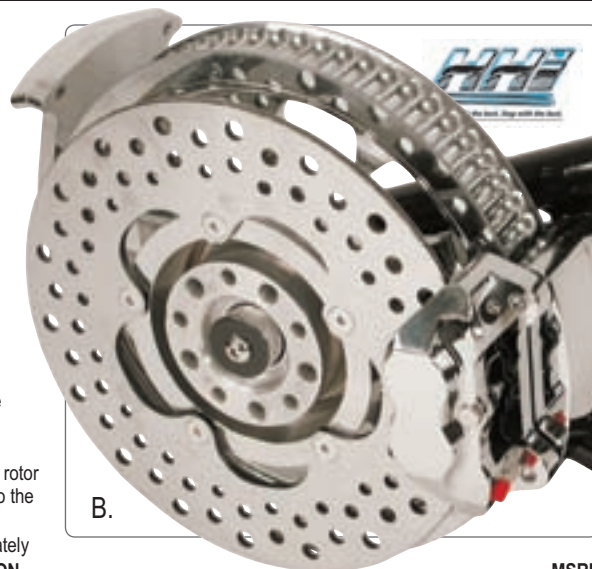

PART	DESCRIPTION	MSRP
Please Call For Custom Fitment & Pricing		

C. Hawg Halters Rigid Rotor Kits

Hawg Halter Rear Kits for rigid frames use time-tested 100 series symmetrical bore 4-piston calipers for great stopping distance with uncompromising looks.

PART	DESCRIPTION	MSRP
HHRKRD11C1	Rear (Right), 11 1/2", 3/4" Axle, For Customs, Chrome	\$510.00
HHRKRD11C3	Rear (Right), 11 1/2", 1" Axle, For Customs, Chrome	\$510.00
HHRKLD11C1	Rear (Left), 11 1/2", 3/4" Axle, For Customs, Chrome	\$510.00
HHRKLD11C3	Rear (Left), 11 1/2", 1" Axle, For Customs, Chrome	\$510.00
HHRKRD10C1	Rear, 10", 3/4" Axle, For Customs, Chrome	\$510.00
HHRKRD10C3	Rear, 10", 1" Axle, For Customs, Chrome	\$510.00

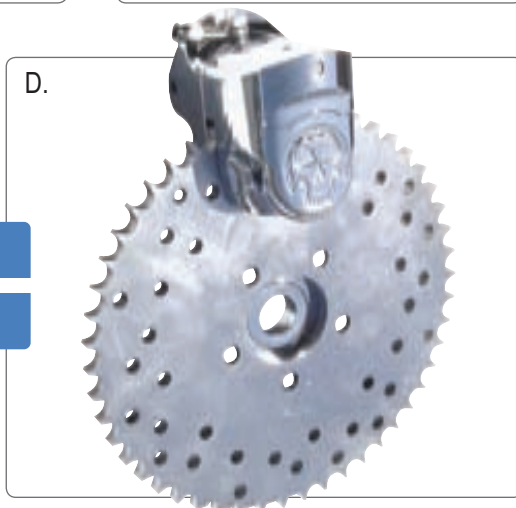
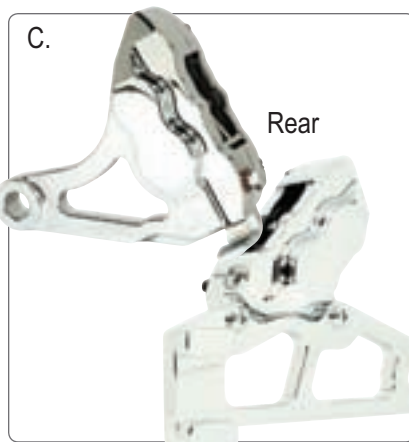



A. Hawg Halters Brake Calipers & Kits

- Uses the latest design 500 series differential bore caliper for optimum stopping
- Stainless steel pistons and chrome hardware — call for black and polished
- Quick change design for easy pad maintenance w/ dual hidden bleeders

Front 4-Piston Calipers For:		MSRP
HHLSC501	'00-Later H-D® (Excludes Springer®), LS, Chrome	\$357.14
HHRSC501	'00-Later H-D® (Excludes Springer®), RS, Chrome	\$357.14
HHLSC500	'84-'99 H-D® (Excludes Springer®), LS, Chrome	\$357.14
HHRSC500	'84-'99 H-D® (Excludes Springer®), RS, Chrome	\$357.14

Front 6-Piston Calipers & Kits For:		MSRP
HHLSC601	'00-Later H-D® (Excludes Springer®), LS, Chrome	\$428.57
HHRSC601	'00-Later H-D® (Excludes Springer®), RS, Chrome	\$428.57
HHLSC600	'84-'99 H-D® (Excludes Springer®), LS, Chrome	\$428.57
HHLNC600	'84-'99 H-D® (Excludes Springer®), LS Narrow, Chrome	\$428.57
HHRSC600	'84-'99 H-D® (Excludes Springer®), RS, Chrome	\$428.57
HHRNC600	'84-'99 H-D® (Excludes Springer®), RS Narrow, Chrome	\$428.57

Front 4-Piston Caliper & Bracket Kits For Springer®:		MSRP
HHFKHSC100	'90-Later Heritage Springer® Softail®, Kit w/ Bracket, Chr.	\$357.14
HHFKSRC100	'88-Later FX Springer®, LS Kit w/ Bracket, Chrome	\$530.61
HHFKCRC100	Custom Springer®, RS Kit w/ Bracket, Chrome	\$551.02
HHFKCLC100	Custom Springer®, LS Kit w/ Bracket, Chrome	\$551.02

Rear 4-Piston Caliper & Brackets For:		MSRP
HHRKSTC501	'00-Later Softail® w/ Stock Axle, Chrome	\$510.20
HHRKSTC500	'84-'99 Softail® w/ .75" Axle, Chrome	\$510.20
HHRKSTC530	'84-'99 Softail® w/ 1" Axle, Chrome	\$510.20
HHRKLSC530	Custom Softail® w/ 1" Axle, RSD, Chrome	\$510.20
HHRKSPC535	'05-'07 XL, Chrome	\$530.61
HHRKSPC504	'04 XL, Chrome	\$530.61
HHRKSPC501	'00-'03 XL, Chrome	\$530.61
HHRKSPC500	'84-'99 XL, Chrome	\$530.61
HHRKHTC532	'02-Later FLH/FLT, Chrome	\$530.61
HHRKHTC500	'84-'99 FLH/FLT, Chrome	\$530.61
HHRKDGC536	'06-Later Dyna™, Chrome	\$530.61
HHRKDGC501	'00-'05 Dyna™, Chrome	\$530.61
HHRKDGC500	'91-'99 Dyna™, Chrome	\$530.61
HHRKFRC500	FXR, Chrome	\$530.61

Brake Rebuild Kits For Hawg Halters		MSRP
HH501002	4-Piston Rebuild Kit	\$30.61
HH101002	4-Piston Rebuild Kit	\$20.41
HH601002	6-Piston Rebuild Kit	\$30.61



B. Stampede™ 4-Piston Billet Brake Calipers

- Smooth lines and durability
- Four aluminum pistons, billet-cut aluminum caliper bodies
- For Softail®/Big Twin applications
- Fitments for right side drive, rigids, FXR, Dyna® and FLT are also available, call for details

PART	DESCRIPTION	MSRP
ST030011	4-Piston Calipers For '84-'98 Softail® BT, Polished	\$385.00
ST030012	4-Piston Calipers For '84-'98 Softail® BT, Chrome	\$462.00
ST030012B	4-Piston Calipers For '84-'98 Softail® BT, Black Anodized	\$467.00

Front Hangers For '84-'99 Softail®		MSRP
ST03005	Polished	\$35.00
ST03006	Chrome	\$41.00
ST03006B	Black Anodized	\$46.00

Front Hangers For '00-Later Softail®		MSRP
ST03015	Left, Polished	\$77.00
ST03016	Left, Chrome	\$93.00
ST03016B	Left, Black Anodized	\$98.00
ST03017	Right, Polished	\$95.00
ST03018	Right, Chrome	\$105.00
ST03018B	Right, Black Anodized	\$112.00

Rear Hangers For '84-'99 Softail®		MSRP
ST03007	Polished	\$107.00
ST03008	Chrome	\$119.00
ST03008B	Black Anodized	\$124.00

Rear Hangers For '00-Later Softail®		MSRP
ST03019	Polished	\$133.00
ST03020	Chrome	\$148.00
ST03020B	Black Anodized	\$153.00

A. Shotgun Shock Air Suspension System

Shotgun Shock is a highly developed product resulting from years of R&D. •

- Nearly instantaneous adjustment of four inches of travel
- Ride height and firmness are independently adjustable
- A completely leak-proof system that operates without external air lines or the performance-robbing air line flex
- Better than stock suspension at any position along the full travel of the swingarm
- Four internally valved solenoids provide for adjustment of both height and firmness
- Air pressure is locked in the billet body resulting in a safe, leak-proof design
- Installation is hassle free since a bracket is provided for the compressor — the wiring is plug and play
- An ultra-clean design with compact packaging of the electronics
- The motorcycle won't drop because of failed lines or fittings
- The system can lock in the pressure — the air pressure has nowhere to flex, resulting in a solid ride and no bottoming out
- Encapsulated valving
- Remote electronic key fob
- Compact compressor unit
- Available in show polish or black

PART	DESCRIPTION	MSRP
SHEVE	Shotgun Shock For '84-'88 Softail®, Polished	\$1,600.00
SHEVEB	Shotgun Shock For '84-'88 Softail®, Pol. w/ Black Case	\$1,550.00
SHEVL	Shotgun Shock For '89-'99 Softail®, Polished	\$1,600.00
SHEVLB	Shotgun Shock For '89-'99 Softail®, Pol. w/ Black Case	\$1,550.00
SHTC	Shotgun Shock For '00-Later Softail®, Polished	\$1,600.00
SHTCB	Shotgun Shock For '00-Later Softail®, Pol. w/ Black	\$1,550.00

A.



B. Hi-Lo Rider Adjustable Shocks For Softail®

- Allows custom adjustments and designs to be made to suit the riding conditions and the design of the bike
- Hi-Lo is well known for the optional remote control kit which allows operation from up to 200 feet from the bike
- Hi-Lo is the only air ride with a lifetime warranty, including two years on the components
- Shocks are made from aircraft grade aluminum that is hard anodized inside and out to eliminate corrosion caused by water in the air
- The hard chromed stainless steel piston shaft uses a double-lipped swell seal
- High strength dust boots over the shaft prevent damage to shaft and seals
- Top of the line chrome air compressor with up to 200 PSI output
- No internal bags to crack or leak
- Easy installation with no modifications to the frame
- Tech service available 7 days a week

PART	DESCRIPTION	MSRP
HLEVP	Hi-Lo Adjustable Air Shocks For '84-'99 Softail®, Polished	\$995.00
HLEVC	Hi-Lo Adjustable Air Shocks For '84-'99 Softail®, Chr.	\$1,095.00
HLTCP	Hi-Lo Adjustable Air Shocks For '00-Later Softail®, Pol.	\$995.00
HLTCC	Hi-Lo Adjustable Air Shocks For '00-Later Softail®, Chr.	\$1,095.00
HLRC	Remote Control Key Fob Kit For Hi-Lo	\$250.00

Hi-Lo Rider Shocks For Indian®, Victory® & Metrics

PART	DESCRIPTION	MSRP
HLICP	Hi-Lo Adjustable Air Shocks For '02-'03 Indian® Chief™	\$995.00
HLVVP	Hi-Lo Adjustable Air Shocks For Victory® Vegas™	\$995.00
HLVKP	Hi-Lo Adjustable Air Shocks For Victory® Kingpin™	\$995.00

C. Progressive Suspension® 422 Series Shocks

- Fully adjustable shock for Softail® with variable ride height and spring preload settings
- Allows the rider to easily tune the suspension to fit the bike as well as riding style
- They are adjustable from stock to 2" lower

PART	DESCRIPTION	MSRP
PS4224037C	422 Series Shocks For '00-'08 Softail®, Chrome	\$499.95
PS4224035C	422 Series Shocks For '89-'99 Softail®, Chrome	\$599.95

B.



C.





A.



B.



C.

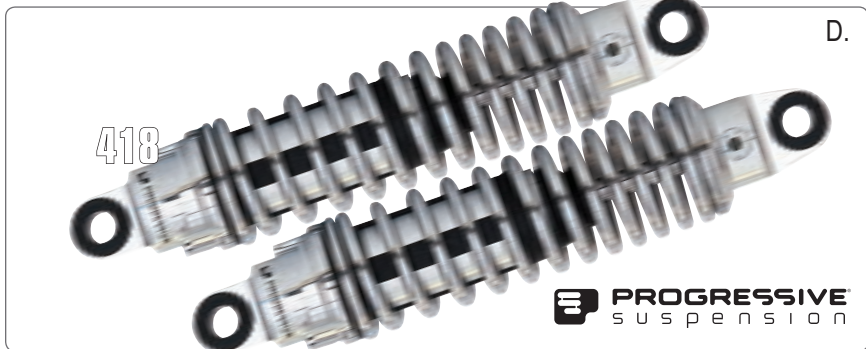

D.

A. Progressive Suspension AirTail® Package

- Twin shock design allows for the use of a linear rate coil shock coupled with a progressive rate air shock for a smooth ride and ultimate bottoming control
- The air shock can be pressurized to lower your bike for that custom look and to set ride firmness independently
- Made with Progressive Suspension custom tuned dampers, the AirTail® offers superior dampening, improving ride quality and control
- Optional on-board compressor kit — dial in your ride with the touch of a button

PART	DESCRIPTION	MSRP
PS7221001	For '89-'99 Softail®	\$799.00
PS7221002	For '00-Later Softail®	\$799.00
Compressor Kits For AirTail®		
PS305100	Compressor Kit For '89-'99 Softail®	\$ 751.85
PS305101	Compressor Kit For '00-Later Softail®	\$ 751.85
PS305109	Compressor Only For Softail®	\$ 339.90
PS305110	Controls w/ Gauge Only For '89-'99 Softail®	\$ 396.55
PS305111	Controls w/ Gauge Only For '00-Later Softail®	\$ 396.55
PS3300	Hand Air Pump For Shocks	Call

B. Progressive® 440 Series I.A.S. Twin Shocks

- Revolutionary Inertia Active System with Inertia Valve technology separates wheel movement from chassis movement
- Progressive rate springs available in standard or heavy duty rates
- Available with chrome covers and chrome springs or black chrome covers with black springs. Also available in classic polished billet and all black
- Powdercoated damper and black nitride shaft
- Available in lengths from 11.0" to 13.5"
- Limited lifetime warranty on I.A.S. dampers

See MCAAdvantages.com For Fitment Information On: Sportster®, FL Models, FX Models (Excluding Softail®) V-Rod® and many more!

C. Bulletproof® Heavy-Duty Replacement Shocks

- Heavy-duty chrome replacement shocks for '89-later Softail®
- Adjustable dampening to control ride comfort
- Recommended for heavy or double riders
- Built-in lowering adjustment for travel from approximately 11" to 11 1/2" in length
- Adjustable dampening to control ride comfort
- Sold in pairs
- Always follow OEM instructions for adjusting shocks — both must be adjusted to same level for safe, balanced ride

PART	DESCRIPTION	MSRP
BPSH223	For '00-later Softail®, Chrome, Adjustable	\$319.99
BPSH211	For '89-'99 Softail®, Chrome, Adjustable	\$296.99

D. Progressive Suspension® 418 Series Shocks

The 418's custom tuned billet aluminum damper body is lightweight and improves ride performance. Their rebound dampening is adjustable to five settings for great tunability. They also feature cam-style preload adjuster in standard or heavy-duty.

See MCAAdvantages.com For Fitment Information On: Sportster®, FL Models, FX Models (Excluding Softail®) V-Rod® and many more!

A. Progressive Suspension® 430 Series Shocks

- High pressure gas mono tube construction for best in class damping performance
- Gas and oil separated by divider piston for absolute fade-free performance
- Deflective disk valves for quick consistent damping
- Can be run rod up or down
- Tool-less pre-load adjustments
- "Nitro-Steel" piston shaft for durability
- Polyurethane bushings for quick response

See MCAAdvantages.com For Fitment Information On: Sportster®, FL Models, FX Models (Excluding Softail®) V-Rod® and many more!



B. Progressive Suspension® 812 & 412 Series Shocks

- Simply the best value shock in the market today.
- The double wall steel body construction with nitrogen charged, multi-staged velocity sensitive valving gives you smooth, consistent dampening.
- 5-position cam style preload adjuster lets you dial in your ride whether you're a light rider or heavy hitter.
- 412 series are the standard shocks shown at left. The 812 series are 412 series shocks with a slick set of chrome slash-cut, baloney cut or flamed covers

See MCAAdvantages.com For Fitment Information On: Sportster®, FL Models, FX Models (Excluding Softail®) V-Rod® and many more!



C. Progressive Suspension® Lowering Kits



Front Lowering Kit



The Progressive® Industry Leader! Their lowering Kits feature a brilliant chrome finish and are available for '88-'06 Softail®.

PART	DESCRIPTION	MSRP
PS305046C	Rear Lowering Kit For '88-'89 Softail®, Chrome	\$124.95
PS305048C	Rear Lowering Kit For '00-'06 Softail®, Chrome	\$124.95

D. Progressive Suspension AirTail® I.A.S. Air Shocks

- Incorporates a coil spring system with a dual chambered air shock for totally independent control of both ride firmness and height
- The I.A.S. (Inertia Active System) helps improve handling performance by separating wheel and chassis movement
- Combine the I.A.S. with the other AirTail® controls and pump options below for the absolute best in custom looks and clean controls.

PART	DESCRIPTION	MSRP
PS7401001C	I.A.S. Unit For '97-Later FLH	\$1,029.95
PS7401002C	I.A.S. Unit For Dyna®	\$1,319.00
PS7401003C	I.A.S. Unit, 12.5"	\$1,358.57

Compressor Kits For AirTail® I.A.S.		MSRP
PS305102	Compressor Kit For '97-Later FLH	\$735.42



E. Hi-Lo Rider Adjustable Shocks For Baggers & Road King®

- All the same great features as the fitments for Softail®, with fitment for Road King® and side-mount baggers
- Remote key fob kit sold separately

PART	DESCRIPTION	MSRP
HLRKP	For Road King® & Side Mount Baggers, Polished	\$995.00
HLRKC	For Road King® & Side Mount Baggers, Chrome	\$1095.00
HLRC	Remote Control Key Fob Kit For Hi-Lo	\$250.00





A.



B.



C.

MEAN STREET® FRONT END OPTIONS INCLUDE:

- 3°, 5°, 6° & 7° Triple Clamp Rakes
- Chromed, Polished & Black Anodized Finishes
- Any Length Configuration
- Single- Or Dual-Disc Calipers

MADE IN THE USA!



D.

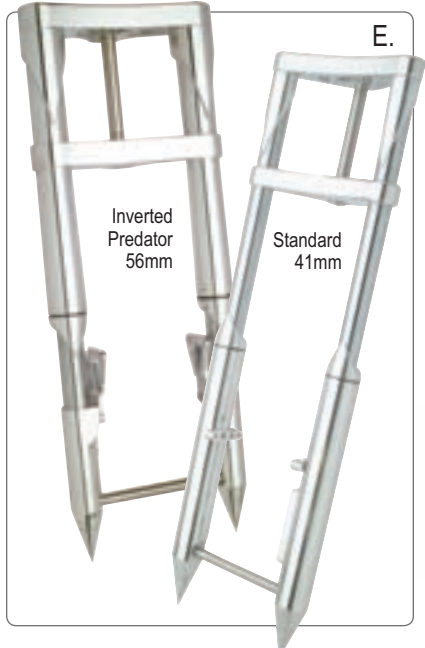

E.



A. Mean Street Avalon Front Ends

Mean Street presents its newest and most adventurous creation. With its dramatic design and seamless flowing lines, Avalon is reminiscent of a contemporary sculpture. If you're going for an upscale look and you want forks to match the level of the rest of your bike, this is it! They are available today in almost any configuration to bring your bike to the top custom level. Mean Street's Avalon is sculpted from solid billet, finished as chrome, polished or black and offers raked triple clamps in 3, 5, 6 and 7° increments. Single- or dual-disc brakes available.

Please Call For Pricing	Avalon, Polished
Please Call For Pricing	Avalon, Chrome
Please Call For Pricing	Avalon, Black
Please Call For All Fitment And Finish Options	1.800.726.9620

B. Mean Street 41mm "Bomber" Mean Series Front Ends

Mean Street's Mean Series front end features beefier lower legs that add style and substance to any bike. Available in three tough looking lower leg styles finished in polished, chrome or black. Single- or dual-disc brakes available.

Please Call For Pricing	41mm Mean Series, Bomber, Polished
Please Call For Pricing	41mm Mean Series, Bomber, Chrome
Please Call For Pricing	41mm Mean Series, Bomber, Black
Please Call For All Fitment And Finish Options	1.800.726.9620

C. Mean Street 56mm Inverted Front Ends

These are the forks that started it all for Mean Street! The BIG billet upper tubes start an impressive lineup that includes smooth-top billet triple clamps, stainless steel steering stem, internal cartridge dampening, hard chrome steel alloy slider tubes and billet lowers. The rust-free stainless steel hardware and axle shaft are included with these front ends. They have a wide variety of custom widths and four different degrees. Single- or dual-disc brakes available. Give your MC Advantages Sales Rep a call to customize your set today.

Please Call For Pricing	56mm Inverted Forks, Street Smooth, Polished
Please Call For Pricing	56mm Inverted Forks, Street Smooth, Chrome
Please Call For Pricing	56mm Inverted Forks, Street Smooth, Black
Please Call For Pricing	Inverted Forks, Stiletto, Chrome
Please Call For Pricing	56mm Inverted Forks, Stiletto, Chrome
Please Call For Pricing	56mm Inverted Forks, Stiletto, Black
Please Call For All Fitment And Finish Options	1.800.726.9620

D. Mean Street 41mm "Hot Rod Forks" Front Ends

Take your Old Skool ride to Bitchinville with the Hot Rod line from Mean Street. They have a unique '50s theme with a huge assortment of finishes, rakes, lengths and widths. Single- or dual-disc brakes available.

Please Call For Pricing	41mm Rumlbers "Hot Rod Forks", Polished
Please Call For Pricing	41mm Rumlbers "Hot Rod Forks", Chrome
Please Call For Pricing	41mm Rumlbers "Hot Rod Forks", Black
Please Call For All Fitment And Finish Options	1.800.726.9620

E. Mean Street Wicked-Style Front Ends

From the darkest corners of Mean Street's twisted imagination comes their Wicked Style forks. These wild fork models feature over the top styling that is not for the timid. All the Wicked Style forks boast billet construction and all the other qualities that set Mean Street apart as a top Quality American made fork. You say you have a taste for the outrageous and walk a bit on the wild side? Mean Street's Wicked front ends are your ticket to the other side of the tracks! Features include:

- Solid stainless steel steering stem with innovative adjustable nut system
- Hard chrome steel alloy sliders and billet lowers
- Semi Hidden axle, stainless steel axle shaft
- Precision springs and internal dampening system.
- Single or Dual disc billet mounts
- Raked Trees available in 3°, 5°, 6° and 7° increments.

Wicked Style, MS Predator, Polished	
Wicked Style, MS Predator, Chrome	
Wicked Style, MS Predator, Black	
Wicked Style, Inverted Predator, Polished	
Wicked Style, Inverted Predator, Chrome	
Wicked Style, Inverted Predator, Black	
Please Call For All Fitment And Finish Options	1.800.726.9620





A. American Suspension B-17 63mm Inverted Front End

- American Suspension's sleek 63mm inverted front ends feature "Look, No Brake Lines!" Phantom Internal™ Brake Lines concealed within the fork
- The strong legs feature a smooth tube transition and a hidden axle for the clean-line look
- Added stopping power is provided with the included Padlock Brake Calipers
- The Black Mamba finish is available on 63mm front ends with Hex or Phantom Brake line styles
- Black Mamba front ends feature black inner and outer tubes, chrome trees, axle clamps and chrome accents
- The Ice Age and Black Ice styles are available with smooth tops or vicious Decapitator trees and legs — Phantom Brakes not available on Ice Age
- Please contact MC Advantages for custom ordering of:

Chrome	Ice Age, Chrome
Black Mamba	Black Ice, Chrome & Black

B. American Suspension 45mm Front Ends

- The same "Look, No Brake Lines!" Phantom Line™ Internal Brake Lines concealed within the fork along with Smooth Top™ Trees
- This single- or dual-disc option front end sports a hidden axle for clean install
- Available in chrome, Ice Age (chrome with custom covers), raw, Black Mamba, Black Ice (two-tone black and chrome) or Brass Monkey Finishes.
- Black finishes feature black inner and outer tubes, chrome trees, axle clamps and chrome accents.
- The Ice Age and Black Ice styles are available with either Batwings (shown on Ice Age) or Decapitator (shown on Black Ice) Trees. The Ice series of front ends feature vicious Saber end caps — Phantom Brakes not available on Ice Age
- Please specify trees when ordering
- Please contact MC Advantages for custom ordering of:

Chrome	Raw
Black Mamba	Ice Age, Chrome
Brass Monkey	Black Ice, Black w/ Chrome

C. American Suspension Hidden Hardware Kit

- Three chromed plugs cover the axle, steering stem hole and headlight bolt hole
- Retrofits many earlier American Suspension forks

PART	DESCRIPTION	MSRP
ASHHC	Hidden Hardware Kit, Chrome	\$59.00

D. American Suspension Banjo Fitting

To connect your -2 Phantom Line™ to your master cylinder, you'll need a -2 fitting. This fitting has a nicer shape and finish than typical.

PART	DESCRIPTION	MSRP
ASBF	Banjo Fitting	\$49.00

E. American Suspension -2 Hose Tool

- If you're going to do a job, do it right, and use the right tools!
- This tool makes installation of the -2 fitting on American Suspension a breeze
- This tool is not required, but it makes your life a lot easier.

PART	DESCRIPTION	MSRP
ASHT	-2 Hose Tool	\$42.00

F. American Suspension Phantom Fork Stop

- Eliminate ugly external steering stops with use of the Phantom™ Fork Stop
- American Suspension Trees accept hidden steering stops.
- Most frames have a tab on the steering neck to work with this unit. If your frame does not have a tab, you either need to weld one on (preferred method) or take the easy way out with the Phantom Stop Bearing Race.

PART	DESCRIPTION	MSRP
ASPFS	American Suspension Phantom™ Fork Stop	\$99.00

American Suspension Padlock Brake Pads & Rebuild

PART	DESCRIPTION	MSRP
ASPBRK	Padlock Brake Rebuild Kit	\$79.00
	Replacement Brake Pads By Performance Plus	Call

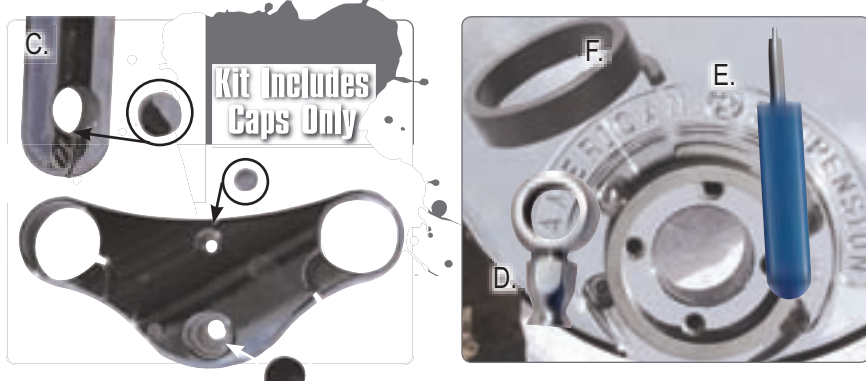
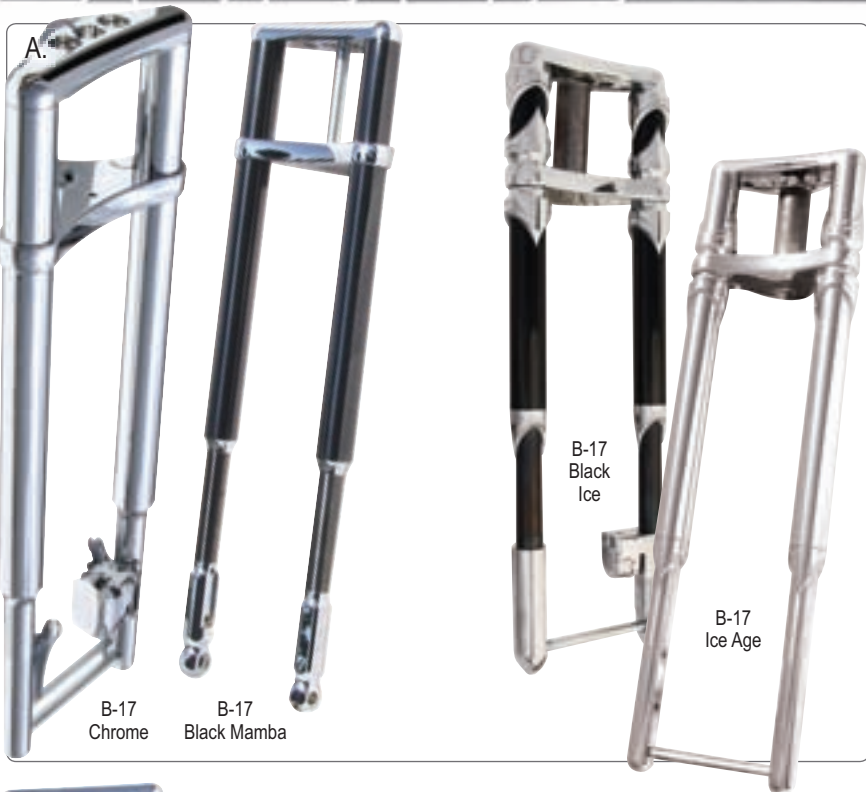



A.



B.

A. Spyke® 63mm Inverted Front End & Accessories

- Speed-sensitive dampening for a plush ride with uncompromising road-holding ability
- Chrome-plated upper tube (63.5mm diameter), hard chrome slider tube (45mm diameter) and smooth-look chrome legs that are machined from billet
- The chrome-plated triple clamps are machined from billet 6061-T6 aluminum
- The front end is set up for single- or dual-disc brakes and is available from 2" under to 24" over — call for longer sizes
- Optional triple trees are drilled for internal for stops

PART	DESCRIPTION	MSRP
SPWG-6	32", 63mm Inverted Front End w/ 6° Trees	\$2,551.02
SPWG	32", 63mm Inverted Front End w/ Standard Trees	\$2,040.00
SPWG2-6	34", 63mm Inverted Front End w/ 6° Trees	\$2,591.02
SPWG2	34", 63mm Inverted Front End w/ Standard Trees	\$2,080.82
SPWG4-6	36", 63mm Inverted Front End w/ 6° Trees	\$2,631.84
SPWG4	36", 63mm Inverted Front End w/ Standard Trees	\$2,121.63
SPWG6-6	38", 63mm Inverted Front End w/ 6° Trees	\$2,672.65
SPWG6	38", 63mm Inverted Front End w/ Standard Trees	\$2,160.41
SPWG8-6	40", 63mm Inverted Front End w/ 6° Trees	\$2,713.47
SPWG8	40", 63mm Inverted Front End w/ Standard Trees	\$2,200.82
SPWG10-6	42", 63mm Inverted Front End w/ 6° Trees	\$2,690.00
SPWG10	42", 63mm Inverted Front End w/ Standard Trees	\$2,240.00
SPFB16	Fender Bracket For 16"-17" Wheel	\$26.95
SPFB18	Fender Bracket For 18"- 21" Wheel	\$26.95
SPFSB	Single Caliper Bracket Kit	\$65.00
SPFDB	Dual Caliper Bracket Kit	\$94.00
SP20183002	Wipers & Seals For Two Legs	\$50.70



D.

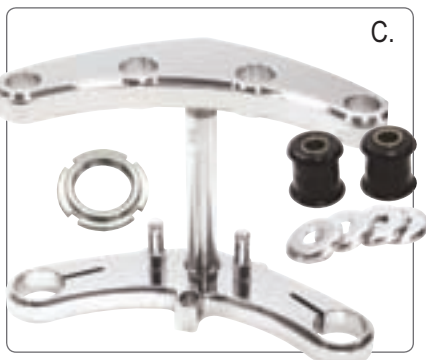

C.

B. Bulletprüf® 41mm Front End

Whether you're building a new front end or rebuilding to OE specs, these front ends and components pack a punch with the durability you need and the looks you demand. Assemblies available from stock to 14" over
 See Price List For Complete Front End Assemblies

C. Bulletprüf® Triple Trees & Components

- This chrome billet triple tree set with 0° rake accepts 41mm tubes and includes hardware, 1" stem bolt, handle bar damper and fork stops
- Features hidden stem nut and underside headlight mount for a super clean look

PART	DESCRIPTION	MSRP
BPFETT	Triple Trees For Wide Glide®/Softail® '36-Later, Set	\$399.00
BPFE626	Chrome Stem Nut, Each	\$10.00
BPFE627	Stem Nut Locktab, 10-Pack	\$10.00



E.

D. American Suspension D-66 Front Ends

- Unique and dramatic upper fork and tree design
- Fits a standard Wide Glide® wheel and has identical wheel spacing to 63mm AS Perimeter Valve Forks
- Available in any length from 4" under to 30" over in rakes of 0° or 3°
- Sealed oversized bearings and zero lift caliper mounts add to the sleek looks and rugged durability of the unit
- Hidden Phantom Brake Line™ option available
- Please contact MC Advantages for custom ordering of:

Chrome	Raw
Black Mamba	Ice Age D-66, Chrome
Brass Monkey	Black Ice D-66, Chrome w/ Black Legs

E. Progressive Suspension® Replacement Front End Springs

- Soak up the small road bumps and absorb the molar-rattling ones
 - You'll be amazed at the improvement you'll feel in the handling and ride of the motorcycle when these are installed
 - Carefully designed to reduce front end dive under braking while providing excellent ride comfort
 - Warrantied for life — fitments available for almost every model
- See MCAAdvantages.com For Complete Fitment Information

F. Progressive® Front End Lowering Kits (Not Shown)

- When combined with shorter rear shocks, it gives a low, custom look
 - Complete with progressive rate fork springs, spacers, and instructions
- See MCAAdvantages.com For Complete Fitment Information

A. GS Motor Company Mono-Shock Leading Link Front End

- Reminiscent of leading link dirt bike forks from the '60s and '70s
- Designed with geometry and handling in mind
- Hydraulically dampened, with more travel than a stock Springer®, you'll like the way they ride
- -3° trees and a reverse bend in the legs give a little less trail for better handling
- Forks come beautifully chrome plated with black trees
- Available in stock length with a 1" diameter neck stem
- The fact that these functionally designed forks look funky — priceless!

PART	DESCRIPTION	MSRP
GS502000	Mono-Shock Leading Link Front End, Chrome	\$1,695.00



B. Kiwi® Motorcycle Company Leaf Spring Forks

- For H-D®, Indian® and custom frames
- Accepts left, right or dual disc brakes
- Forks are made from 1020 DOM material for 16"-21" wheels for bobbers, choppers and customs
- Standard length is 21"
- Lengths of -1" to 5" available
- Non-standard orders require extra lead time
- Top crown (not shown) available for accepting almost any risers

KMLSF	Leaf Spring Forks	\$1,899.00
KMLSFC	Fork Crown	\$149.99



C. Roadmax Front Ends For Springer®

- Quality chrome front end with axle
- Available in +2", +4" and +6"



MSRX38	+6" Length	\$799.00
MSRX36	+4" Length	\$799.00
MSRX34	+2" Length	\$799.00

D. Martin Bros.® Fork Brace

- Constructed from hardened $\frac{3}{16}$ " steel, chromed to a show finish
- Eliminates flopping on extended front ends
- Comes with 1" billet spacers.

MBF01CH	Martin Bros.® Fork Brace, Chrome
---------	----------------------------------



E. Stampede™ Fork Braces

- Eliminates fork flex
- Reduces wobbles
- Reduces front end vibration
- For Wide or Narrow Glide® and Deuce® models
- Increases tire life

STFBNGT1	Tribal Fork Brace For '87-Later Narrow Glide®	\$105.00
STFBWGT1	Tribal Fork Brace For '87-Later Wide Glide®	\$105.00
STFBNGS1	Smooth Fork Brace For '87-Later Narrow Glide®	\$105.00
STFBWGS1	Smooth Fork Brace For '87-Later Wide Glide®	\$105.00



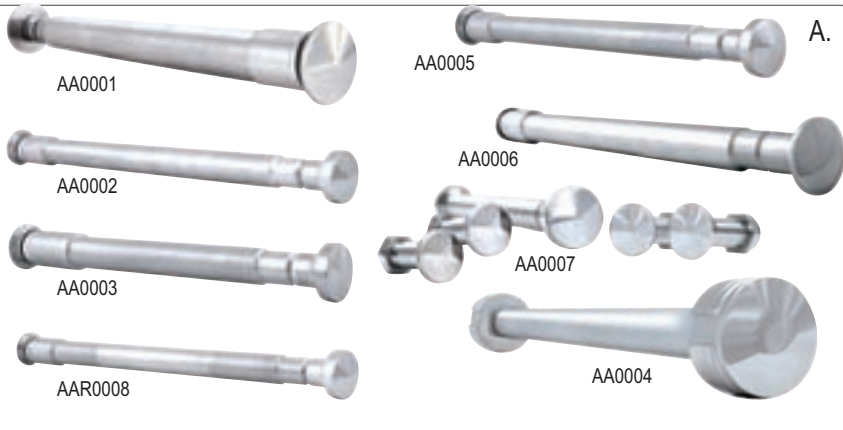

A. Adjure® Flush-Mount Axles

- Remove ugly hex nuts and lugs with a chrome flush mount front axle.
- Smooth sleek lines with a broad fitment listing — even for Springer®!

PART	DESCRIPTION	MSRP
Front Axle Fitment For:		
AA0001	'00-'07 Touring Models w/ 1" Axle	\$119.95
AA0002	'84-99 FL Touring Models, '84-'06 FXST, '84-'86 FXWG 4-Speed, '93-'05 Dyna® Wide Glide	\$119.95
AA0003	'87-99 FXR & Dyna® Narrow Glide® w/ 39mm Forks	\$119.95
AA0005	'86-'06 FLST, Excludes Heritage Springer®	\$119.95
AA0006	Deuce®	\$119.95
AA0007	'88-Later Softail® Springer® (5 Piece Set)	\$189.95
Rear Axles		
AAR0001	Replaces OEM 41110-79A	\$198.95
AAR0002	For Dyna™ Wide Glide®, Replaces OEM #41114-90	\$198.95

B. Stampede™ WideTire Kits For Sportster™



- Rectangular swingarm kits available for 240 tires
- Rectangular swingarm kits come complete with pulley, pulley side plate, swingarm, axle, and fender struts
- Round swingarm kit has shapely form for smooth custom look
- Round swingarm kit comes with .75" axle
- Specify year of bike, drive side and tire size when ordering

PART	DESCRIPTION	MSRP
STWSP240-4	240 Kit For '04-'06 XL, Rectangular Swingarm	\$1,149.00
STWSP240	240 Kit For '91-'03 XL, Rectangular Swingarm	\$999.99
STWSP240	240/250 Kit For '91-'03 XL, Round Swingarm	\$1,345.00
STWSP240-4	240/250 Kit For '04-Later XL, Round Swingarm	\$1,345.00
STWSP180	180/200 Kit For '91-'03 XL, Round Swingarm	\$1,345.00
STWSP180-4	180/200 Kit For '04-Later XL, Round Swingarm	\$1,345.00

**WIDE TIRE
 KITS FOR
 SPORTSTER®**

C. Kraft/Tech 300 WideTire Kit For Stock Softail® Frame

- True bolt-on with only minimal cutting required
- Swingarm is 1 3/8" mandrel bent DOM steel tubing
- 13.5" one-piece 14 gauge deep drawn strutless fender
- Stainless steel splash guard included
- **Requires RSD transmission**
- Includes 1" axle kit w/polished stainless steel axle cover and hardware
- Separate front and rear belt guards are available in natural or chrome



PART	DESCRIPTION	MSRP
STXFRW0075	300 Wide Tire Kit w/ High Torque Swingarm	\$1,466.53
STXFRW0076	300 Wide Tire Kit w/ Dagger Swingarm	\$1,466.53
STXFRW0077	300 Wide Tire Kit w/ Curved Dagger Swingarm	\$1,567.99



A. Kraft/Tech Fender Braces For Rigid

• The braces are fabricated from by Kraft/Tech from .25" thick steel, then styled to enhance the lines of frame, fender and that big, bad wheel & tire

PART	DESCRIPTION	MSRP
For Stamped Rigid Frames Using Flat Fenders:		
STXFB001	For 7" Fat Bob® Fenders, Chrome	\$22.50
STXFB002	For 7.5" Flat Fenders, Chrome	\$28.75
STXFB003	For 8.5" Flat Fenders, Chrome	\$30.75
STXFB004	For 9" Flat Fenders, Chrome	\$33.00
STXFB005	For 5"-6" Flat Fenders, Chrome	\$20.50
For Stamped Rigid Frames Using Wide-Round Top Fenders:		
STXFB008	For 180mm Rigid w/ 1.375" Axle Carrier & 9" Fenders	\$60.00
STXFB009	For 230-250mm Rigid w/ 1.5" Axle Carrier & 11" Fenders	\$60.00
STXFB010	For 280mm Rigid w/ 1.5" Axle Carrier & 12.5" Fenders	\$60.00
STXFB011	For 300mm Rigid w/ 1.5" Axle Carrier & 13.5" Fenders	\$60.00
STXFB012	For 300mm Rigid w/ 1.375" Axle Carrier & 9" Fenders	\$60.00
STXFB013	For 230-250 Rigid w/ 1.375" Axle Carrier & 11" Fenders	\$60.00
STXFB014	For 180mm Rigid w/ 1.375" Axle Carrier & 9" Fenders	\$60.00
STXFB015	For 200mm Rigid w/ 1.375" Axle Carrier & 9" Fenders	\$60.00
STXFB016	For 230-250 Rigid w/ 1.375" Axle Carrier & 11" Fenders	\$60.00

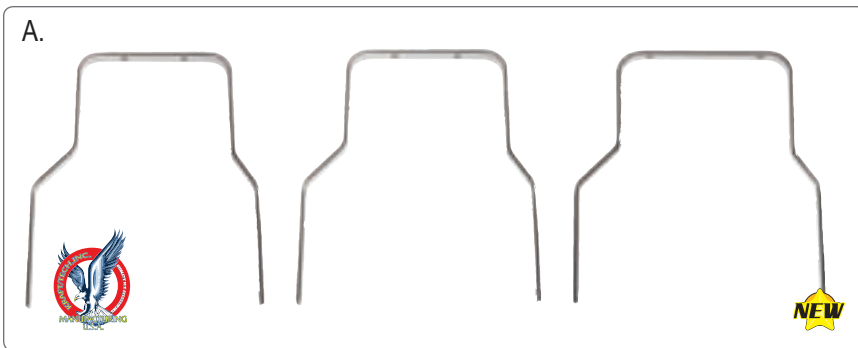

B. Kraft/Tech Rear Fender Struts & Braces

• Manufactured by Kraft/Tech for MC Advantages customers!
• Mounting hardware comes with each set

Curved Fender Struts For Softail®		MSRP
STXFS007	Fits 7.5" Fenders, Chrome	\$214.27
STXFS005	Fits 8.5" Fenders, Chrome	\$214.27
STXFS013	Fits 8.5" Fenders, Raw	\$128.56
STXFS001	Fits 9" Fenders, Chrome	\$214.27
STXFS003	Fits 9" Fenders, Raw	\$128.56
Straight Fender Struts For Softail®		MSRP
STXFS014	Fits 8.5" Fenders, Chrome	\$214.27
STXFS004	Fits 8.5" Fenders, Raw	\$128.56
STXFS009	Fits 9" Fenders, Chrome	\$214.27
STXFS011	Fits 9" Fenders, Raw	\$128.56



Solid Contour Struts For Softail®		MSRP
CNC Radiused		
STXFS016	Fits 7.5" Fenders, Raw	\$171.41
STXFS017	Fits 7.5" Fenders, Chrome	\$271.41
STXFS020	Fits 8.5" Fenders, Raw	\$171.41
STXFS021	Fits 8.5" Fenders, Chrome	\$271.41
Slotted Contour Struts For Softail®		
STXFS018	Fits 7.5" Fenders, Raw	\$242.84
STXFS019	Fits 7.5" Fenders, Chrome	\$342.84
STXFS022	Fits 8.5" Fenders, Raw	\$242.84
STXFS023	Fits 8.5" Fenders, Chrome	\$328.56
STXFS024	Fits 9" Fenders, Raw	\$171.41
STXFS025	Fits 9" Fenders, Chrome	\$271.41
STXFS026	Fits 9" Fenders, Raw	\$242.84
STXFS027	Fits 9" Fenders, Chrome	\$328.56
STXFS028	Fits 11" Fenders, Raw	\$171.41
STXFS029	Fits 11" Fenders, Chrome	\$271.41
STXFS030	Fits 11" Fenders, Raw	\$242.84
STXFS031	Fits 11" Fenders, Chrome	\$328.56

C. Front Fender Bracket For Deuce®

• 100% polished stainless steel
• Fits FXSTD lower fork legs and most fenders designed for a 21" wheel when using Wide Glide® Triple Trees.
SCDFM Fender Bracket, Pair \$172.00

D. Stampede® Fender Spacers

Ultra sleek billet aluminum spacers for narrow fenders and Wide Glide® front ends
ST7001 Oval Fender Spacer, Chrome \$69.00
ST7FB Billet Fender Spacers \$42.00

E. Paul Yaffe Originals Front Fenders

• Deep drawn from 12 gauge steel (bullet proof and the strongest available)
• These babies aren't spun and welded, they are made from one piece!!
• Each fender is shipped raw and not drilled so it can be slammed down low
• Additional fender spacing is required

PART	DESCRIPTION	MSRP
PYFF13	Wild Front Fender For Wide Glide®	\$299.95
PYFF12	Wild Front Fender For Deuce®	\$299.95
PYFF19	DEI Front Fender For 21" x 5"	\$299.95
PYFF20	Thicky Front Fender For 21" x 5"	\$299.95
PYFF18	Hi-5 Front Fender For Wide Glide®	\$299.95
PYFF14	Hi-5 Front Fender For Deuce®	\$299.95
PYFF2	Talon Front Fender For Wide Glide®	\$299.95
PYFF1	Talon Front Fender For Deuce®	\$299.95



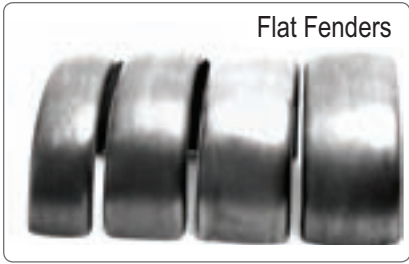

Flat Fenders



Fender & Struts



Skirtd Fenders



Fenders w/ Welded Struts



Strutless Fenders



9" Fat Fender



Round Top Strutless



Wide Round Top Strutless

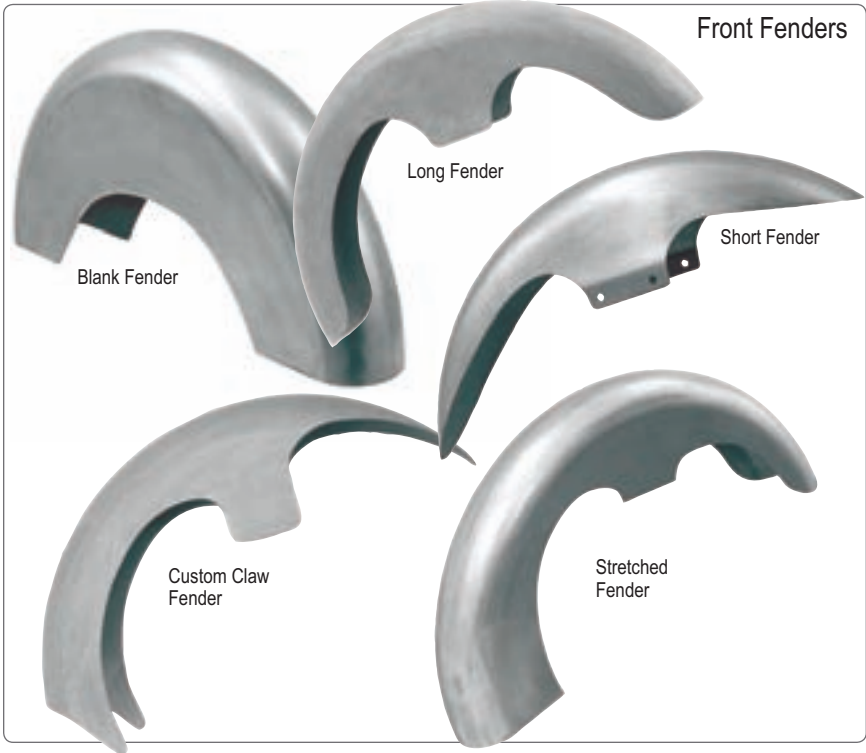

Front Fenders

Blank Fender

Long Fender

Short Fender

Custom Claw Fender

Stretched Fender

A. Kraft/Tech Rear Fenders

- Durable 14 gauge, one-piece steel fenders that won't crack!
- Designed with current low-profile tire technology in mind
- 9" fenders fit 180/200; 11" fit 230/240/250; 12.5" fit 280 & 13.5" fit 300

PART	DESCRIPTION	MSRP
STXF001	Flat Fender, 6"	\$42.84
STXF002	Flat Fender, 7.5"	\$42.84
STXF003	Flat Fender, 8.5"	\$42.84
STXF004	Flat Fender, 9"	\$42.84
STXF033	Flat Fender & Strut Kit For Softail®, 8.5", Raw Struts	\$185.70
STXF034	Flat Fender & Strut Kit For Softail®, 9", Chrome Struts	\$237.86
STXF035	Flat Fender & Strut Kit For Softail®, 9", Raw Struts	\$185.70
STXF007	Skirtd Fender, 7.5", Radius-Cut Sides	\$142.84
STXF008	Skirtd Fender, 8.5", Radius-Cut Sides	\$142.84
STXF005	Skirtd Fender, 9", Curved Sides	\$142.84
STXF009	Skirtd Fender, 9", Radius-Cut Sides	\$142.84
STXF017	Skirtd Fender, 9", Angle-Cut Sides	\$142.84
STXF037	Fender w/ External Welded Struts For 180-200 BT Softail®, 9"	\$428.56
STXF039	Fender w/ External Welded Struts For 180-200 TC Softail®, 9"	\$528.56
STXF038	Fender w/ External Welded Struts For 230-240 Softail®, 11"	\$471.41
STXF040	Round Top Strutless Fender For 180 BT Softail®, 9"	\$557.13
STXF044	Round Top Strutless Fender For 180 TC Softail®, 9"	\$557.13
STXF041	Round Top Strutless Fender For 230-240 BT Softail®, 11"	\$471.41
STXF043	Round Top Strutless Fender For 230-240 TC Softail®, 11"	\$571.41
STXF100	Wide Round Top Strutless Fender For 280 BT, 12.5"	\$714.27
STXF101	Wide Round Top Strutless Fender For 280 TC, 12.5"	\$714.27
STXF102	Wide Round Top Strutless Fender For 280 BT, 13.5"	\$714.27
STXF103	Wide Round Top Strutless Fender For 280 TC, 13.5"	\$714.27
STXF104	Wide Round Top Strutless Fender For 330 BT, 13.5"	\$857.13
STXF050	Round Top Fender For Softail®, Untrimmed, 9"	\$171.41
STXF051	Round Top Fender For Softail®, Trimmed, 9"	\$171.41
STXF054	Round Top Fender For Rigid, Untrimmed, 9"	\$171.41
STXF055	Round Top Fender For Rigid, Trimmed, 9"	\$171.41
STXF052	Round Top Fender For Softail®, Untrimmed, 11"	\$178.56
STXF053	Round Top Fender For Softail®, Trimmed, 11"	\$178.56
STXF056	Round Top Fender For Rigid, Untrimmed, 11"	\$178.56
STXF057	Round Top Fender For Rigid, Trimmed, 11"	\$178.56
STXF063	Round Top Fender For Rigid, Trimmed, 11", No Belt-Cutout	\$178.56
STXF058	Round Top Fender For Rigid, Untrimmed, 12.5"	\$185.70
STXF059	Round Top Fender For Rigid, Trimmed, 12.5", Left Side-Cut	\$185.70
STXF060	Round Top Fender For Softail®, Untrimmed, 12.5"	\$199.99
STXF061	Round Top Fender For Softail®, Trimmed, 12.5"	\$199.99
STXF062	Round Top Fender For Rigid, Trimmed, 12.5", No Belt-Cutout	\$185.70
STXF070	Round Top Fender For Rigid, Trimmed, 12.5", Right Side-Cut	\$178.56
STXF064	Round Top Fender For Softail®, Untrimmed, 13.5"	\$199.99
STXF065	Round Top Fender For Softail®, Trimmed, 12.5"	\$199.99
STXF066	Round Top Fender For Rigid, Untrimmed, 13.5"	\$192.84
STXF067	Round Top Fender For Rigid, Trimmed, 13.5", Left Side-Cutout	\$192.84
STXF068	Round Top Fender For Rigid, Trimmed, 13.5", No Belt-Cutout	\$192.84
STXF069	Round Top Fender For Rigid, Trimmed, 13.5", Right Side-Cut	\$192.84
STXF110	Round Top Fender For 3330 Softail®, 14.5"	Call
STXF079	Fat Fender For '84-Later Softail® & Custom Apps, 9"	Call

B. Kraft/Tech Front Fenders

- 14 gauge steel fenders are a perfect match for 21" front tire designs.
- Manufactured using a deep-draw process that withstands huge amounts of riding

PART	DESCRIPTION	MSRP
STXF080	Short Fender, 4.75", (Un-Drilled)	\$114.27
STXF081	Short Fender, 4.75", (Drilled)	\$114.27
STXF088	Short Fender, 5.50", (Un-Drilled)	\$114.27
STXF089	Short Fender, 5.50", (Drilled)	\$114.27
STXF082	Blank Fender, 4.75", (Un-Trimmed)	\$142.84
STXF092	Blank Fender, 4.25", (Un-Trimmed) Stretched	\$142.84
STXF093	Blank Fender, 5.50", (Un-Trimmed) Stretched	\$142.84
STXF083	Long Fender, 4.75", (Trimmed)	\$142.84
STXF090	Long Fender, 4.25", (Stretched)	\$142.84
STXF091	Long Fender, 5.50", (Stretched)	\$142.84
STXF084	Stretched Fender, 4.75", (Square Cut Bottom)	\$142.84
STXF094	Stretched Fender, 4.25", (Square Cut Bottom)	\$142.84
STXF095	Stretched Fender, 5.50", (Square Cut Bottom)	\$142.84
STXF086	Custom Claw Fender, 4.25" Wide	\$142.84
STXF087	Custom Claw Fender, 5.50" Wide	\$142.84

A. Crime Scene Choppers "Vendetta" Oil Tank

- Walks the styling line between cool old school and crazy modern!
- Includes two stainless straps, rubber channels, fittings, fill cap & mount bars
- Mounted horizontally or vertically
- Cast aluminum, 11.5" x 3" x 6" with a 2.5 quart capacity

PART	DESCRIPTION	MSRP
CSC676	Satin	\$692.00
CSC677	Chrome	\$799.00

A.



B. Crime Scene Choppers "Hard Times" Oil Tank

- Cast aluminum with deep cooling fins on the ends and a stock drop-in filter
- Measures 6" diam. x 11.5", holds 4.5 quarts with internal lines for ultra-clean look
- Fine satin finish with highlight polished fins.
- Includes startup kit with 5/16"-18 rubber isolator mounts, both caps, filter element, line fittings and magnetic drain plug

PART	DESCRIPTION	MSRP
CSC600	Finned Oil Tank	\$762.00

B.

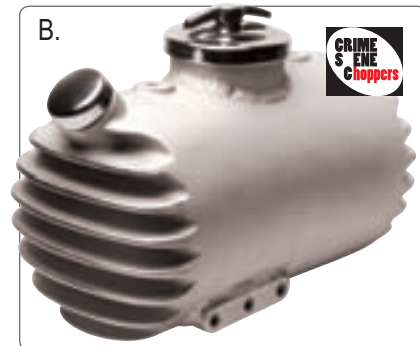

C.



STXLT047

C. Kraft/Tech Horseshoe & Winged Oil Tanks

- Beautiful lustrous chrome or ready-to-prep & paint raw finish
- Most provide better oil circulation and cooling via re-routed lines that return oil to the far side of the tank
- Mounting brackets available separately

PART	DESCRIPTION	MSRP
------	-------------	------

For Softail® & Rigid, 3 Qt.

STXLT005	Horseshoe Side Fill, Chrome	\$235.70
STXLT006	Horseshoe Side Fill, Natural	\$185.70
STXLT011	Horseshoe Center Fill, Chrome	\$271.41
STXLT019	Horseshoe Center Fill, Natural	\$185.70
STXLT014	Winged Side Fill, Chrome	\$271.41
STXLT033	Winged Side Fill, Chrome w/ Threaded Oil Line Holes	\$257.13
STXLT076	Winged Center Fill, Natural	\$199.99
STXLT032	Winged Center Fill, Chrome w/ Threaded Oil Line Holes	\$257.13
STXLT034	Winged Side Fill, For 180-250mm, Chrome	\$314.27
STXLT023	Winged Side Fill, For 180-250mm, Natural	\$199.99
STXLT031	Winged Side Fill, For 180-250mm, w/ Threaded, Chrome	\$285.70
STXLT079	Winged Center Fill, For 240-250mm, Natural	\$285.70
STXLT077	Winged Center Fill, For 300mm, Natural	\$299.99
STXLT078	Winged Center Fill, For 300mm, Chrome	\$414.27

For FXR, 4 Qt.

STXLT109	Winged Side Fill, For 180/200mm Polished Stainless	\$357.13
----------	--	----------

For '65-'83 4-Speed FX/FXE/FL, 3.5 Qt.

STXLT001	Side Fill, Chrome	\$242.84
STXLT012	Side Fill w/ Chrome Spin-On Filter, Chrome	\$285.70
STXLT025	Side Fill w/ Chrome Spin-On Filter, Raw	\$242.84

For '58-'64 Rigid or Early Swingarm Frames, 4 Qt.

STXLT020	Side Fill, Chrome	\$257.13
STXLT016	Side Fill w/ Chrome Spin-On Filter, Chrome	\$285.70
STXLT026	Side Fill w/ Chrome Spin-On Filter, Raw	\$228.56

D. Kraft/Tech Round Oil Tanks

- Handcrafted from high-quality 16 gauge steel.
- Universal models measure 5.5" x 11.75", battery box models are 6.5" x 11.75"
- Rear mounting brackets sold separately

PART	DESCRIPTION	MSRP
------	-------------	------

Universal Oil Tank, 4 Qt.

STXLT047	Side Fill, Chrome	\$264.27
STXLT048	Side Fill, Raw	\$242.84

Built-Battery Box, 3.5 Qt

STXLT057	Side Fill, For Stock Softail® & Rigid, Chrome	\$457.13
STXLT058	Side Fill, For Stock Softail® & Rigid, Raw	\$414.27
STXLT059	Center Fill, For Stock Softail® & Rigid, Chrome	\$457.13
STXLT060	Center Fill, For Stock Softail® & Rigid, Raw	\$399.99
STXLT049	Side Fill, For 200-250 Softail®, Chrome	\$471.41
STXLT050	Side Fill, For 200-250 Softail®, Natural	\$414.27
STXLT051	Center Fill, For 200-250 Softail®, Chrome	\$457.13
STXLT052	Center Fill, For 200-250 Softail®, Natural	\$414.27

D.



STXLT005

STXLT032

STXLT019

STXLT001

STXLT012

STXLT016



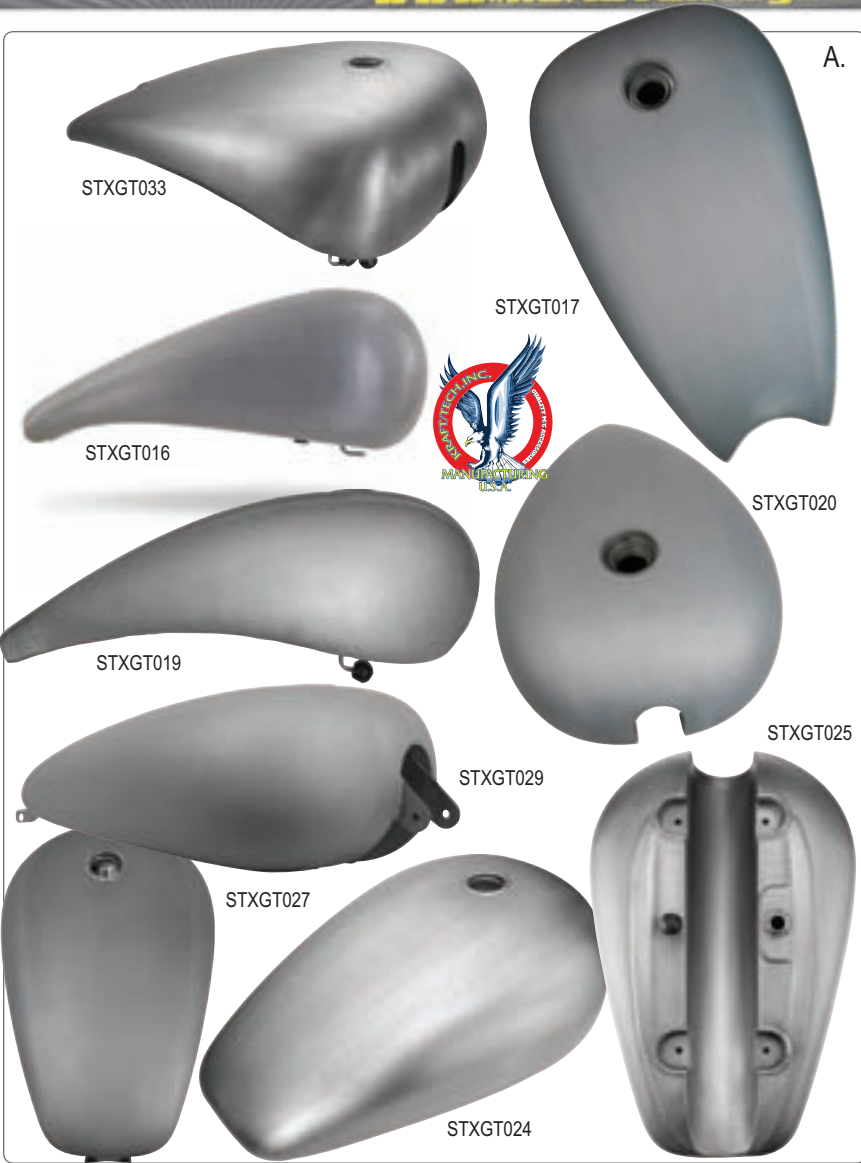

A.

A. Kraft/Tech Gas Tanks

- Great one-piece stretched custom gas tanks.
 - 14 gauge deep-drawn mild steel for optimal fit and finish.
 - Amazingly smooth welds that ensure an effective seal and save prep time.
 - Tank is mounted to the frame using the supplied weld-on brackets.
 - Installed brackets mount to the gas tank using a recessed grommet mounting system that isolates the tank from vibration and optimizes the sleek custom look
 - Etch coat sealer prevents corrosion and provides ideal primer/paint adhesion. Includes frame-weld brackets, grommets & mounting hardware, stainless filler bung, stainless 1/8" (22mm) petcock bung, stainless breather tube and stainless rear mounted gas crossovers tapped for 1/8" NPT unions.
 - Gas caps sold separately
 - Tanks hold 3 1/2 to 4 gallons depending on part number.
- IMPORTANT NOTE:** All gas tanks must be pressure tested, cleaned with tank cleaner and sealed before painting to protect the final finish and prevent internal rusting during winter storage. Always install the gas tank before painting to check fork, triple tree and handlebar control clearances.

PART	DESCRIPTION	MSRP
Mild Steel Stretched Custom Gas Tanks w/ Closed Fronts		
STXGT016	3" Stretch w/ Screw-Type Bung	\$685.70
STXGT017	3" Stretch w/ Pop-Up Style Bung	\$685.70
STXGT032	2" Stretch For Custom Softail®, Screw-Type Bung	\$714.27
STXGT033	2" Stretch For Custom Softail®, Pop-Up Style Bung	\$714.27
Chopper Gas Tank, Square Cut Rear, Closed Front		
STXGT019	Tank w/ Screw Type Bung	\$671.41
STXGT020	Tank w/ Pop-Up Style Bung	\$699.99
Late Model Gas Tank For Sportster®		
STXGT024	Tank w/ Screw-Type Bung	\$399.99
STXGT025	Tank w/ Pop-Up Style Bung	\$428.56
STXGT027	Tank w/ Recessed Mounts, Screw-Type Bung	\$542.84
STXGT029	Tank w/ Recessed Mounts, Pop-Up Style Bung	\$571.41

U.S. Choppers Custom Gas & Oil Tank



- 100% TIG welded and hand fabricated for the U.S. Choppers boardtrack frame
- Money back **guarantee to have no imperfections and perfect alignment**
- Features dual-chamber design with a gas side and oil side
- Includes both gas and oil cap as well as a petcock

PART	DESCRIPTION	MSRP
USCGT	Custom Gas & Oil Tank	\$1,075.00

B. Stampede™ Fuel Tank Liner Kit

- A simple three step process that enables builders to seal fuel tanks from minor seam, weld or pinhole leaks
- It also seals out existing rust and eliminates future rust or rust debris that may form in older tanks
- Stampede™ Fuel Tank Liner remains flexible to allow for tank expansion and contraction, but will never crack, flake or peel away from the tank
- Each kit contains the cleaner, prep and liner to seal a tank

PART	DESCRIPTION	MSRP
STN01258	Fuel Tank Liner Motorcycle Kit	\$59.99
STN01253	Fuel Tank Liner, 1 Pint	\$24.99
STN01251	Fuel Tank Liner, 1 Qt.	\$49.99
STN01252	Fuel Tank Liner, 1 Gal.	\$149.99
STN01255	Fuel Tank Prep M.E.K., 1 Qt.	\$24.99
STN012577	Fuel Tank Cleaner SF77, 1 Qt.	\$24.99

EASIEST KIT AVAILABLE!



B.

A. Bulletpruf™ Flush-Mount Pop-Up Gas Cap

- Fitment for right and left sides of H-D® Tanks
- **Screw into existing tank bung for flush-mount and pop-up looks**
- Left side fits all years except those with fuel gauge in cap
- Right side fits all except for '93-later models due to interference from vent tube

PART	DESCRIPTION	MSRP
BPG101R	Right, Vented	\$65.00
BPG102L	Left, Non-Vented	\$65.00



B. Crime Scene Choppers "Speedster" Gas Cap

A perfect old-school/hardcore look for your bike. Mounting this gas cap requires a separate blind-tapped base plate

PART	DESCRIPTION	MSRP
CSC207	Flip-Top Gas Cap w/ Stainless Steel Fasteners	\$239.00
CSC206	Flip-Top Gas Cap w/ Brass Fasteners	\$239.00
CSC211	Weld-In Base Plate, Aluminum	\$25.00
CSC210	Weld-In Base Plate, Steel	\$25.00



C. L.A. County Choprods® Crown Gas Caps

- Machined from 6061-T6 aluminum
- Use non-vented or vented by removing the stainless steel set screw on bottom
- Weld-in bung is included to allow stand off or flush-mounting

PART	DESCRIPTION	MSRP
LACGB	Crown Gas Cap, Black, Bung Included	\$169.00
LACGP	Crown Gas Cap, Polished, Bung Included	\$169.00
LACGG	Crown Gas Cap, 24K Gold, Bung Included	\$169.00



D. Flush-Mount Pop-Up Gas Cap

- Leak-proof vent and all stainless steel construction
- The weld-in bung is 2.25" diameter
- Mounts perfectly flush with surrounding tank

PART	DESCRIPTION	MSRP
STFMGC	Flush-Mount, Pop-Up Vented Gas Cap	\$179.99



E. Stampede™ Insta-Pan Seat Pan Kit

- Gain huge time and cost savings with this high-strength kit
- No more hammered sheet metal or pouring fiberglass
- Combine two clay-like components, then roll them out onto provided fiberglass fabric, cut to shape then lay in place to cure overnight.
- Two-part epoxy material with integrated Kevlar® pulp is super strong and can be machined like hardwood
- Kit makes one seat pan approximately 14" X 24", dual riders requires large kit

PART	DESCRIPTION	MSRP
STSPK	Insta Pan Seat Pan Kit, 96 oz.	\$145.00
STSPKL	Insta Pan Seat Pan Kit, 128 oz.	\$194.99

F. Grandeur Cycle® Seat Mount Kit



- Pins install in seat pan before seat is covered
- Requires drilling of three holes in frame to insert the three Delrin® pin receivers

PART	DESCRIPTION	MSRP
GRSMK	Seat Mount Kit	\$40.00



A.

A. Polypan Gel Seat Pan Kit

- Create a clay perimeter of your planned seat shape
- A simple two-part composite is then applied with ordinary brushes
- Sets up overnight to give you a custom form-fitted seat pan

PART	DESCRIPTION	MSRP
MSSP	Polypan Seat Pan Kit	\$145.00

B. Crime Scene Choppers "Hard-Ass" Seat

Crime Scene's "Hard-Ass" seat combines old school cool with a modern look. The seat is precision investment cast solid stainless steel, polished to a blinding mirror finish. It features padded inserts in your choice of black/red/white leather or red metal flake vinyl. Mounting bosses for a pivot and springs are machined right into the seat, so it's ready to go. Any standard solo seat springs can be used with the seat. An ultra-low pivot kit and springs are available separately. It's made from investment cast 17-4 stainless steel, heat treated and polished. About 11.5" wide x 11.75" long. Four bosses 3/8" UNF bosses machined into the bottom for mounting.

Matching companion pads are available. Fabricated from 300 series stainless steel and mirror polished. With the same insert material as Hard-Ass Seat.

The Low-Mount Pivot Assembly is specifically designed to mount any solo seat as low as possible, and it is ideal for the Hard-Ass solo seat. The pivot is fabricated from 316 stainless steel and TIG welded. It includes two SAE 841 self-lubricating bronze bushings and an 18-8 precision stainless shoulder bolt. Two mounting tabs are provided to weld to your frame.



PART	DESCRIPTION	MSRP
CSC104	Red Flake Inserts	\$475.00
CSC102	Red Leather Inserts	\$475.00
CSC101	Black Inserts	\$475.00
CSC103	White Insert	\$475.00
CSC204	Red Flake Companion	\$190.00
CSC202	Red Leather Companion	\$190.00
CSC201	Black Companion	\$190.00
CSC203	White Companion	\$190.00
CSC121	Low-Rise Seat Pivot	\$89.00



B.

C. P.B. Choppers Old School Seat

- Chrome pivot mount that mimics the leaf-spring front ends
- Includes custom rear spring mounting bracket

PART	DESCRIPTION	MSRP
PJSK	Old School Seat	\$549.99



C.

D. Stampede™ Sissy Bars

- These chrome steel sissy bars are manufactured from .625" round material
- Both bars are designed to mate with 9" flat fenders and 180-200 tires
- The tilt back measures 32" high, height above the brace is 19", the width (inside to inside) at the bottom is 11.5"
- The straight model measures 30.5" high, height above the brace is 17.25", the width (inside to inside) at the bottom 11.5"

PART	DESCRIPTION	MSRP
STXS006	Tilt Back Sissy Bar For Rigid	\$113.00
STXS007	Straight Sissy Bar For Rigid	\$113.00

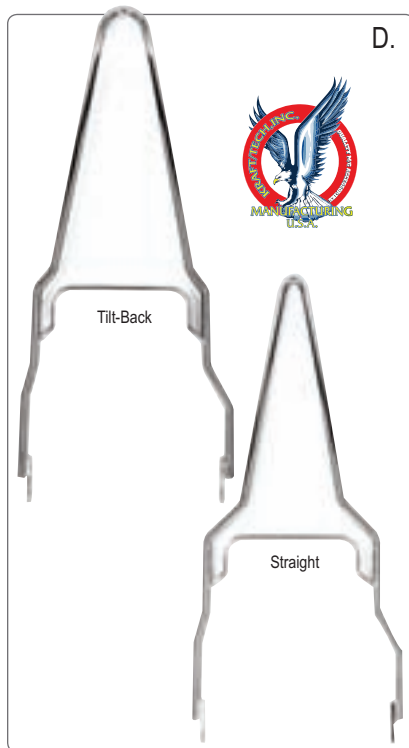

D.



A. US Choppers Boardtrack Racer Frame

- A single cradle design and low slung weight distribution allow for incredible lean angles and an insanely fun ride on this frame.
- Fits most '39-later BT up to 124", excluding shovelheads
- Comes complete with internal fork stop kit, rear axle and rear axle eccentrics
- Integrated gas/oil tank available separately, see sheetmetal section

PART	DESCRIPTION	MSRP
USCFBTR	Board Track Racer Frame, 160/16"	\$2,399.99

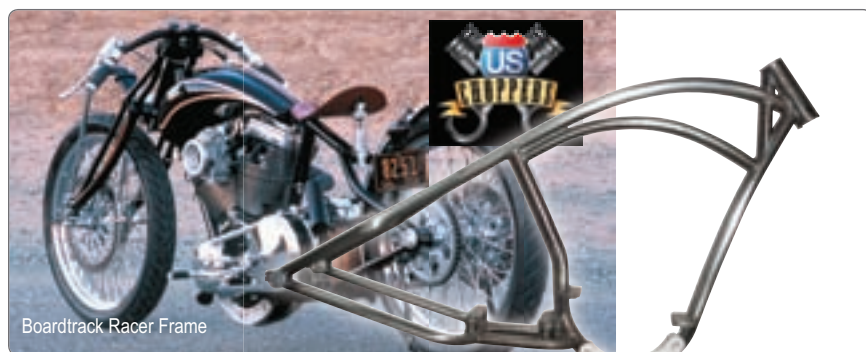

Boardtrack Racer Frame

B. Martin Bros.® Trendkill HT Frame

- Fitting a 280 tire with a belt or 300 tire with a chain, the Trendkill HT RSD Rigid Frame gives bikes the long, lean futuristic look
- Features a 1" up, 6" out stretch and boasts a low 42° or 47° rake
- Includes 1" axle, axle plates and fork stop

PART	DESCRIPTION	MSRP
MBTKHT42	Trendkill Frame w/ 42° Rake	\$3,200.00
MBTKHT47	Trendkill Frame w/ 47° Rake	\$3,200.00



B.

C. Stampede™ Customizable Rigid Frame

Pick from a 300, 280 or 250 size, three different gussets, three different rear axle blocks, two different oil tanks, then select a rake and stretch.

All Stampede™ Rigid Frames feature:

- Single 2" x .187" DOM steel downtube
- Welded engine and tranny plates
- Custom fit oil tank

Stampede™ Customizable Rigid Frame Please Call For Custom Pricing

D. Stampede™ Customizable Rigid Dropseat Frame

Pick from a 330, 300, 280 or 250 size, three different gussets, three different rear axle blocks, two different oil tanks, then select your rake and stretch.

All Stampede™ Rigid Dropseat Frames feature:

- Single 2" x .187" DOM steel downtube
- Curved 1 3/4" x .187" curved steel backbone
- Welded engine and tranny plates
- Custom fit oil tank

Stampede™ Customizable Rigid Frame Please Call For Custom Pricing

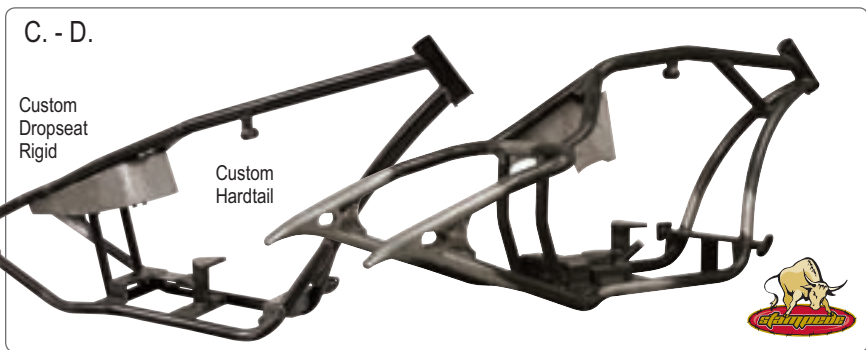

C. - D.

Custom Dropseat Rigid

Custom Hardtail

E. Kraft/Tech Rigid Frames

- DOM 1.25" steel tube frames are TIG-MIG welded
- Accept most Evolution®, Panhead and Shovelhead motors
- Please note engine to ensure correct fitment
- Frames that include axle kits have a 3/4" axle unless noted
- Frames with transmission mount feature an easy-to-use weld-on transmission plate for better strength and easy alignment

PART	DESCRIPTION	MSRP
STXFRR001	Stock, 30° Rake, 0" Stretch	\$786.65
STXFRR051	Stock, 30° Rake, 0" Stretch, Includes Tranny Mount	\$853.32
STXFRR002	Stock, 34° Rake, 2" Stretch	\$826.65
STXFRR052	Stock, 34° Rake, 2" Stretch, Includes Tranny Mount	\$906.65
STXFRR006	180mm, 30° Rake, 0" Stretch, Includes Axle Kit	\$933.32
STXFRR056	180mm, 30° Rake, 0" Stretch, Incl. Axle Kit & Trans Mount	\$1,039.99
STXFRR007	180mm, 34° Rake, 2" Stretch, Includes Axle Kit	\$986.65
STXFRR057	180mm, 34° Rake, 2" Stretch, Incl. Axle Kit & Trans Mount	\$1,066.65
STXFRR060	180mm, 34° Rake, 4" Stretch, 1.5" Backbone Stretch, Includes Axle & Fork Cup Kit & Transmission Mount	\$1,199.99
STXFRR066	Fits 230-250, 34° Rake, 2" Stretch, Includes 1" Axle Kit	\$1,333.32



E.

F. Stampede™ Rigid Conversion Kits For Evolution® XL

- A great new kit from Stampede™ to shake the old school out of you!
- If a rigid old school frame is your gig, make one out of a tired Sporty!
- This hardtail frame kit is the only one on the market for '79-'05 Sportster® frames
- Cut and weld are required, but the frame comes with pre-installed splicer tubes for an easy install.

PART	DESCRIPTION	MSRP
STFRXLK	Stock Width Rigid Conversion Kit For Sportster®	\$890.00
STFRXLK18	180-200mm Rigid Conversion Kit For Sportster®	\$890.00
STFRXLK24	240-250mm Rigid Conversion Kit For Sportster®	\$890.00



F.

BUILD A RIGID FROM AN XL!

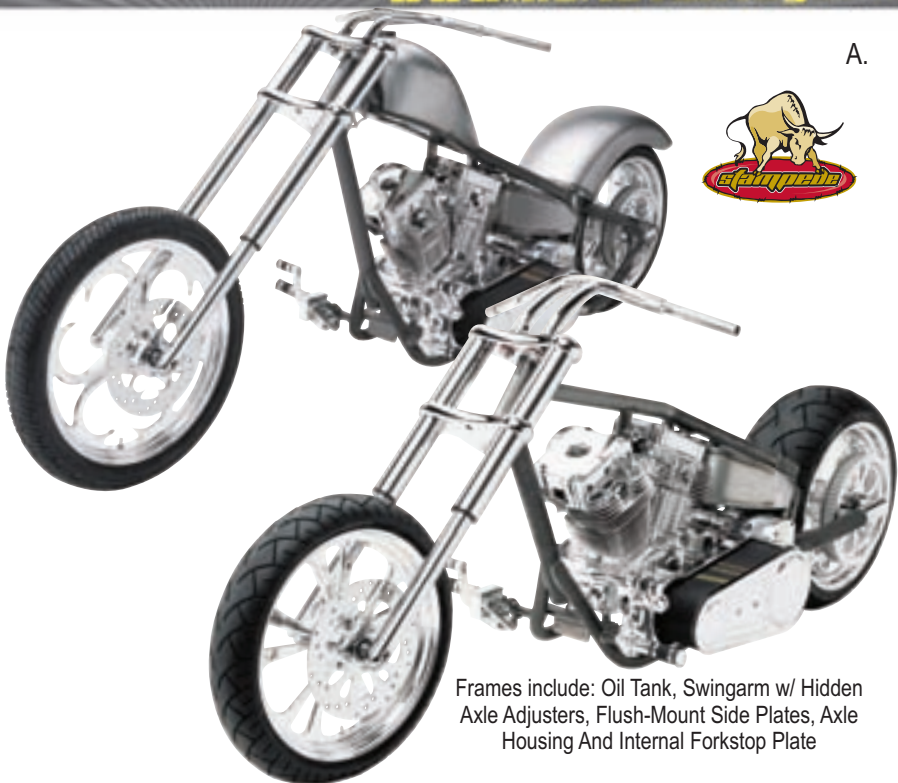

A.



Frames include: Oil Tank, Swingarm w/ Hidden Axle Adjusters, Flush-Mount Side Plates, Axle Housing And Internal Forkstop Plate

A. Stampede™ 250 To 300 Hidden Suspension Roller & Powertrain Packages

Stampede's Chopper Hidden Suspension Frame:

- Can be ordered from a 250 to 300 swingarm
- Has a 40° rake, 6" stretch and a 3" extended backbone but can also be modified to your specifications — including left-side or right-side drive formation

Stampede's Prostreet Hidden Suspension Frame:

- Can be ordered from a 200 to 330 swingarm
- It has a 38° rake and 3" stretch, but can also be modified to your specifications, including left-side or right-side drive formation

Both frames feature:

- CNC-machined mounts and side plates
- Fixture TIG welding for added strength
- 1 1/2" frame rails, 1 3/4" backbone, and a 2" single downtube made of DOM
- Options for the frame include a dropseat and curved/radius downtube and more

Stampede roller packages can include:

- The Stampede™ frame
- Your choice of Spyke®, Bulletprüf®, American Suspension, Mean Street, Kiwi or GS Motor Front Ends
- Shotgun Shock, Progressive Suspension®, Bulletprüf® or Hi-Lo Rider Suspension
- **FREE** Stampede™ Chrome Forward Controls

Check out our powertrain packages in the engine section!

Chopper Hidden Suspension Roller Package	Please Call For Custom Pricing
Prostreet Hidden Suspension Roller Package	Please Call For Custom Pricing
250-300 Chopper Hidden Suspension Frame	Please Call For Custom Pricing
250-300 Prostreet Hidden Suspension Frame	Please Call For Custom Pricing

B. Stampede™ 360 Hidden Suspension Frame

Bust out of the herd with the widest of the wide from Stampede! This 360 Dropseat Hidden Suspension frame utilizes intelligent design for a comfortable ride. Instead of continually widening out the seat area and creating an uncomfortable ride, the uprights have been moved inside of the belt or chain. Available with numerous customization options. Call today for a custom quote.

360 Hidden Suspension Dropseat Frame Please Call For Custom Pricing



B.



C. Stampede™ WideTire Hidden Suspension Dropseat Frame

Pick from a 330, 300, 280 or 250 size; dual or single-side swingarm, three different gussets, four different uprights, then select your rake and stretch.

Stampede™ Hidden Suspension Dropseats feature:

- Welded engine and tranny plates
- Custom fit oil tank
- Axle covers
- **Swingarms available separately**

Dropseat Hidden Suspension Frame Please Call For Custom Pricing

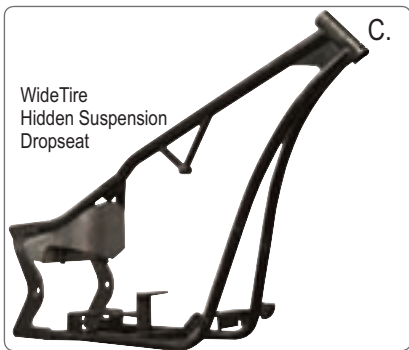

WideTire Hidden Suspension Dropseat

C.

D. Stampede™ Single-Sided Swingarm

The ultimate custom part. Only the baddest boys on the block roll with this look. Fit a 300 or 280 swingarm to Stampede™ conventional or dropseat RSD hidden suspension frames.

Stampede™ Single-Sided Swingarm Please Call For Custom Pricing



D.

E. Kraft/Tech Double Downtube Dagger 300-330 Frames

The Dagger Frame will tear through common designs like nobody's business. Give your MC Advantages Sales Rep a call to find out more about this extremely powerful frame setup.

PART	DESCRIPTION	MSRP
Dagger Swingarm 300-330mm 1.25" Dual Downtube Frames		
KT16129	38° Rake, 0" Stretch, 5" Backbone Stretch w/ 1.5" Tube	\$2,464.75
KT16130	40° Rake, 0" Stretch, 5" Backbone Stretch w/ 1.5" Tube	\$2,464.75
KT16131	38° Rake, -2" Stretch, 5" Backbone Stretch w/ 1.5" Tube	\$2,464.75
KT16132	40° Rake, -2" Stretch, 5" Backbone Stretch w/ 1.5" Tube	\$2,464.75
Dagger Swingarm 300-330mm 1.25" Dual Downtube Frames		
KT16125	38° Rake, 0" Stretch, 5" Backbone Stretch w/ 1.5" Tube	\$2,464.75
KT16126	40° Rake, 0" Stretch, 5" Backbone Stretch w/ 1.5" Tube	\$2,464.75
KT16127	38° Rake, -2" Stretch, 5" Backbone Stretch w/ 1.5" Tube	\$2,464.75
KT16128	40° Rake, -2" Stretch, 5" Backbone Stretch w/ 1.5" Tube	\$2,464.75

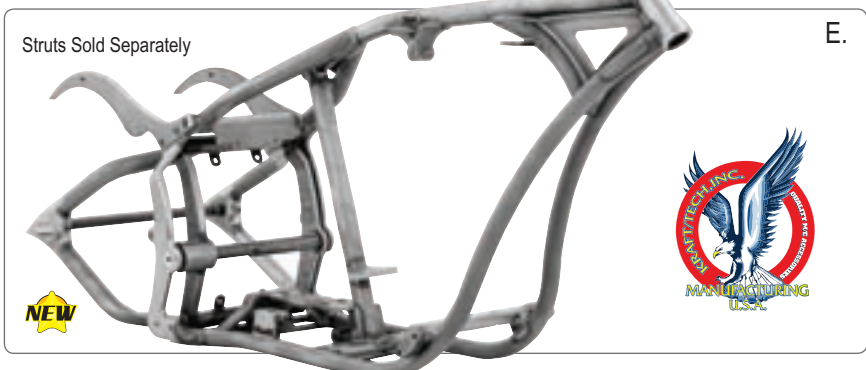

Struts Sold Separately

E.



A. Stampede™ Standard Hidden Suspension Frames For TC

- Designed for stock '00-Later H-D® TC fitments
- The super durable 1.25" DOM tubing is perfect for the rebuild or custom one-off
- These frames are sold without rear sections, swingarm available separately
- These frames ship complete with Manufacturer's Statement of Origin.

PART	DESCRIPTION	MSRP
STXFRT065	Fits Stock Width, 1 1/4" Tube, 30° Rake, 0" Stretch	\$1,253.32
STXFRT068	Fits Stock Width, 1 1/4" Tube, 35° Rake, 0" Stretch	\$1,253.32

A.



B. Stampede™ Standard Hidden Suspension Frames

- These frames are TIG-MIG welded by Kraft/Tech
- They will accept most Evolution®, Panhead and Shovelhead motors
- Please note engine to ensure correct fitment
- Includes stock coil and oil tank mounts as well as a component kit
- Swingarms are sold separately on all models except STXFERS053

PART	DESCRIPTION	MSRP
STXFERS001	Fits Stock Width, 1 1/8" Tube, 30° Rake, 0" Stretch	\$839.99
STXFERS051	Fits Stock Width, 1 1/4" Tube, 30° Rake, 0" Stretch	\$933.32
STXFERS002	Fits Stock Width, 1 1/8" Tube, 34° Rake, 2" Stretch	\$933.32
STXFERS003	Fits Stock Width, 1 1/8" Tube, 38° Rake, 2" Stretch	\$933.32
STXFERS053	Fits 230-250, Single Down, 1 3/8" 38° Rake, 2" Stretch, 5" BBone Str.	\$933.32

B.



C. Kraft/Tech Swingarms For Softail®



Match up our replacement swingarms to one of our hidden suspension frames or direct replace for OEM #47537-89A! These swingarms fit standard width '87-'99 Softail® setups.

PART	DESCRIPTION	MSRP
STXFRW009	Replacement Swingarm For Stock '87-'99 Softail®	\$359.99
STXFRW023	Round Tube Swingarm For Stock '87-'99 Softail®	\$266.65

D. Stampede™ Customizable LXR Frame

Our popular LXR series is a dual downtube frame with optional back/down stretch, and forward or mid controls. Each LXR features standard:

- Curved 1 1/4" x .187" tubing
- Complete TIG welding
- Swingarm with hidden axle adjusters
- 17-4 Stainless steel axle
- Billet swingarm pivot blocks
- Billet hidden coil mount w/ battery box
- Neck races
- Internal fork stops

Stampede™ Custom LXR Frame Please Call For Custom Pricing

D.

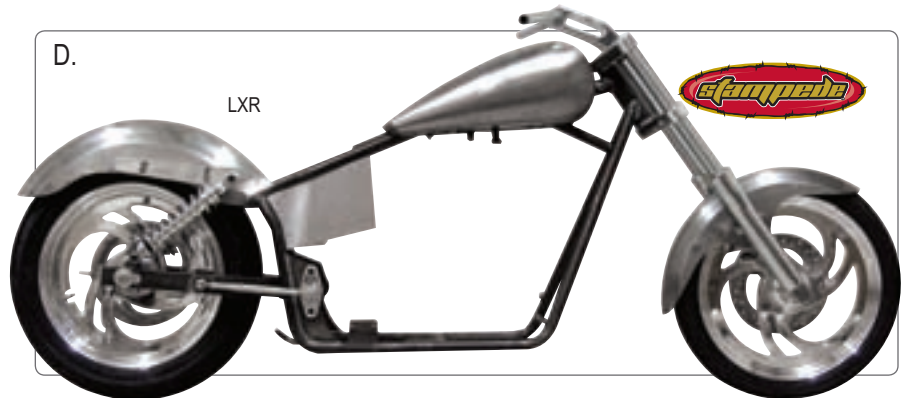

E.

NEW LOW PRICE!



E. Prowler® Hidden Suspension Frames

- Prowler frames are set up for right-side drive and fit tire sizes from 240 to 250
- They feature a shot-peened surface, swingarm with bearings, weld-on gas tank mounts, internal fork stops, built-in neck bearing cups, splash guard, oil tank, integrated transmission plate and 1" rear axle with adjusters and covers

PART	DESCRIPTION	MSRP
PR141DD	Prostreet-Style Frame	\$1,999.00
PR141HM	Halfmoon Chopper Frame	\$1,999.00

F. Stampede™ Frame Gussets

Add to your Stampede™ frames any of these three classic gusset designs. They are also available separately for welding to other frames.

PART	DESCRIPTION	MSRP
STFGF	Flamed Gusset	\$60.00
STFGW	Spider Web Gusset	\$60.00
STFGP	Plain Gusset	\$60.00



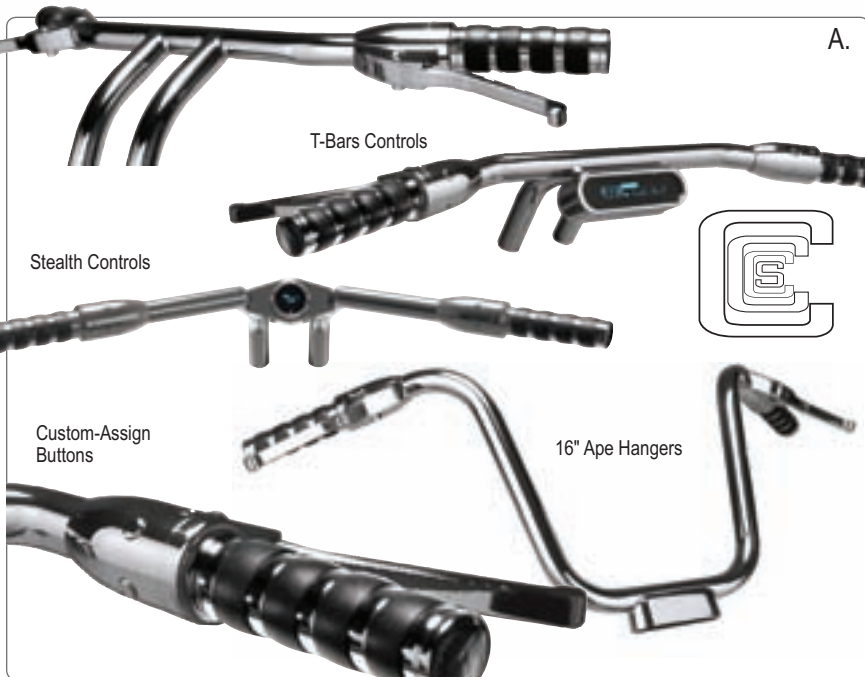

A. Custom Cycle Control Systems®

- The ultimate in clean minimalism
- 7 micro switches whose functions are not labeled, allowing you to assign them for various functions; i.e., air suspension, nitrous, etc
- Reservoirs are concealed and there are no visible wires, cables or hoses.
- Ships complete and fully assembled including install kit with throttle cables, hydraulic fittings, etc
- Many additional special order styles available, see MCAdvantages.com or <http://dealers.mcadvantages.com>

PART	DESCRIPTION	MSRP
CBTB	T-Bars Controls	\$2,395.00
CBTB6000	T-Bars w/ DD6000 Gauge	\$3,190.00
CBST3013	Stealth w/ DD3013 Speedometer/Odometer	\$2,995.00
CBST3015	Stealth w/ DD3015 Speedo/Tach Combo	\$3,170.00
CBAP16	Ape Hangers, 16"	\$2,395.00
CBSLV01	In-Line Slave	\$210.00
CBHSC01	Hydraulic Side Cover	\$338.00
Six Grip Options		See MCAdvantages.com

B. Wild 1® Chubby Bars

These thick, 1 1/4" bars have fluid bends at precise angles for maximum comfort and control. They're pre-drilled for internal wiring, dimpled, diamond knurled and feature an unparalleled show chrome finish.

PB: Pull Back **SR:** Straight Rise **ER:** End Rise
OC: On-Center **CW:** Center Width **WI:** Width

PART	DESCRIPTION	MSRP
Drag Bars:		
W0500	6" Drags ER:4" WI:30.5"	\$209.95
W0501	8" Drags ER:5" WI:30.5"	\$209.95
W0507	10" Drags ER:5" WI:30.5"	\$209.95
W0511	Dragster Bar WI:30.5"	\$129.95
W0560	Low Profile Drags PB:14.5" ER:4" WI:30.5"	\$214.95
T-Bars:		
W0562	Chopper T-Bar SR:8" WI:30.5"	\$214.95
W0563	Chopper T-Bar SR:10" WI:30.5"	\$214.95
Knuckle Bars:		
W0503	Knuckle ER:2" PB:8.5" WI:36.5"	\$204.95
Beach Bar:		
W0550	Beach Bar ER:3.5" PB:15.25" WI:36.5" CW:10"	\$214.95
Ape Hangers:		
W0513	8.5" Ape ER:8.5" PB:11" WI:36" CW:10"	\$219.95
W0515	10" Ape ER:8.5" PB:11" WI:36" CW:10"	\$219.95
W0509	16" Ape ER:16" PB:12.5" WI:37" CW:10"	\$224.95
W0570	18" Ape ER:18" PB:12.5" WI:37" CW:10"	\$239.95
W0571	20" Ape ER:20" PB:12.5" WI:37" CW:10"	\$244.95

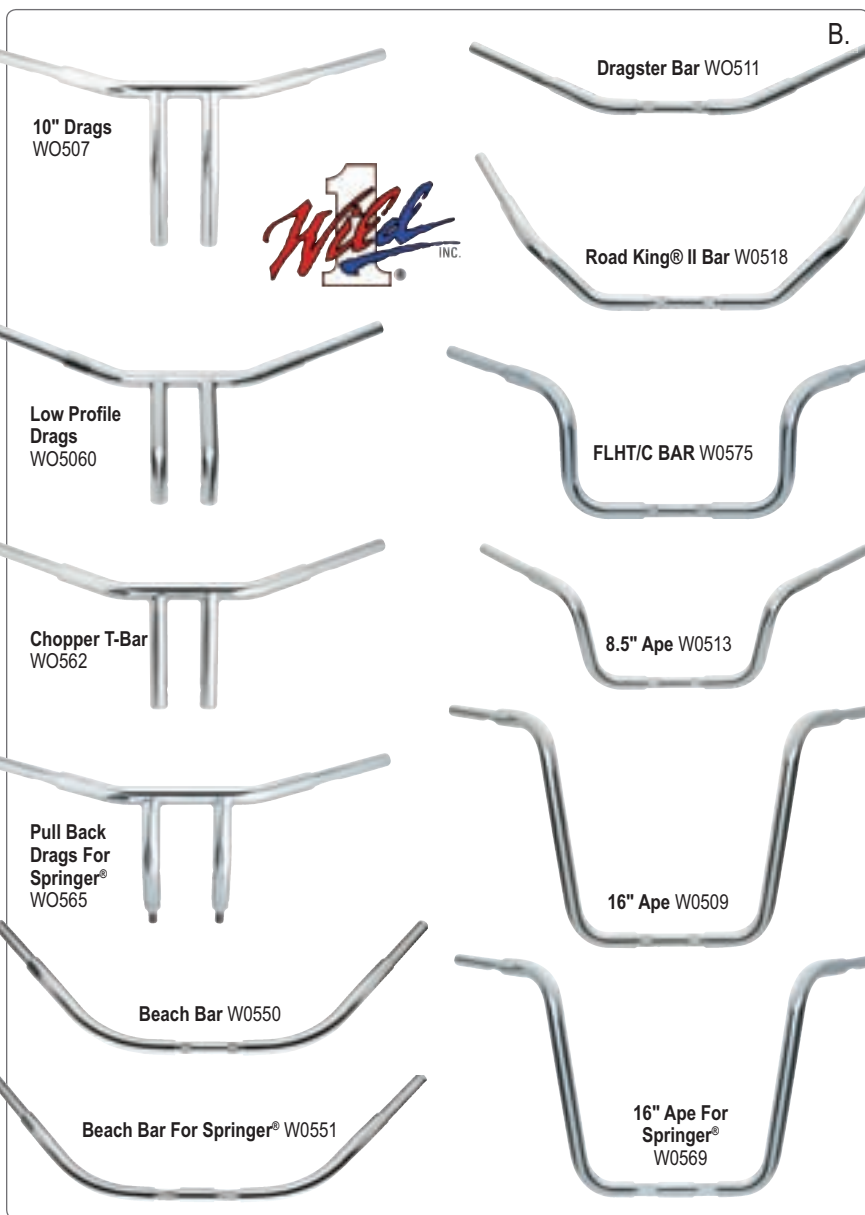

Bars For Touring Models

W0508	For Road King® ER:5.5" PB:16" WI:32.5" CW:12"	\$204.95
W0518	For Road King® II ER:5.5" PB:14.25" WI:35.5" CW:12"	\$204.95
W0517	For Road Glide® ER:4.5" PB:12.5" WI:34.5" CW:10"	\$209.95
W0575	FLHT/C BAR ER:10" PB:13" WI:34.5" CW:10"	\$214.95
W0504	FLSTC/FLSTF ER:4.5" PB:12.5" WI:34.5" CW:10"	\$204.95

Bars For Springer®

W0510	Standard FLSTS ER:4.5" PB:12.5" WI:34.5" CW:12"	\$204.95
W0512	Dragster Bar	\$129.95
W0565	Pull Back Drags OC:4.75" PB:11" WI:30.5"	\$299.95
W0519	Knuckle Bar ER:2" PB:8.5" WI:36.5" CW:10.5"	\$204.95
W0551	Beach Bar ER:3.5" PB:14.75" WI:36.5" CW:11"	\$214.95
W0514	9.5" Ape ER:9.5" PB:11" WI:36.5" CW:12"	\$219.95
W0516	12.5" Ape ER:12.5" PB:12" WI:36.5" CW:12"	\$224.95
W0569	16" Ape ER:16" PB:12.5" WI:37" CW:10"	\$239.95

ENGINE
 FUEL SYSTEMS
 EXHAUST
 ELECTRICAL
 DRIVETRAIN
 WHEELS
 SUSPENSION
 SHEETMETAL
 FRAMES
 CONTROLS
 LIGHTING
 BAGGERS
 TOOLS
 APPAREL

A. Grandeur Cycle® "Mr. Clean" Handlebars

- Built-in throttle pre-installed for the lowest, leanest look on the street
- Bars are 1 1/4" raw polished stainless steel DOM tubing.
- Included grips are polished Stainless Steel.
- Works great with Auto Clutch, see driveline section

PART	DESCRIPTION	MSRP
GRMCBARP	Polished Bar w/ Stainless Flush Grips, Left Mirror Mount	\$995.00
GRMCBAR	Natural Bar w/ Stainless Flush Grips, Left Mirror Mount	\$825.00

A.



B. Stampede™ Concealed Throttle & Clutch Kits

- Total custom concealment with this clutch and throttle from Stinger CC
- Made of precision-machined zinc-plated mild steel
- A unique design with hard brass rollers that are guided through a 5/16" helical groove that smoothly pulls the cable then returns to its original position when released — for the clutch mechanism, a reducer pulley is included for installation in the transmission side cover for ease and function
- True 1" design, compatible with any grip and any style of handlebar

PART	DESCRIPTION	MSRP
STITC	Concealed Clutch	\$489.99
STITS	Concealed Throttle	\$199.99

B.



Shown w/ Missile Grip, Not Included

C. Stampede™ Internal Throttle

- Positive stop at closed and full throttle
- Precision machining and double precision roller bearings for smooth, long-life operation
- Stock bars will require some modification

PART	DESCRIPTION	MSRP
STIT05	1" Internal Throttle	\$179.99
STIT6	1 1/8" Outer Sleeve	\$10.00
STIT4	Replacement Bearings	\$12.88

C.



D.



D. GP Designs Spike Risers

- Hand crafted of 6061T-6 aluminum
- The 12-piece assembly creates a clean appearance with its show quality chrome while offering the full strength of a standard riser.
- Fit 1" handlebars
- Made in the USA

PART	DESCRIPTION	MSRP
GP069	GP 6" Spike Chopper Risers	\$429.95

E. Bulletpruf™ Handlebar Control Switches

E.



- Switch covers feature symbol icons
- Does not fit units with radio controls
- Includes brake light lever switch shim for solid fit
- Easy to install OEM color-coded switch harnesses are 70" long!

PART	DESCRIPTION	MSRP
BP1032C	Switches w/ 70" Wires For '96-Later Models, Chrome	\$119.99
BP1036B	Switches w/ 70" Wires For '96-Later Models, Black	\$119.99



Motion Pro Argent Cables

- Bright silver textile weave
- Clear protective coating protects chrome and painted surfaces
- Premium chrome fittings
- Clutch cables are available in coil-wound or longitudinally-wound
- Longitudinally-wound clutch cables resist compression under heavy loads for a precise, non-mushy feel and enhanced clutch performance
- Image is for reference only, actual product may vary
- **Contact MC Advantages for exact fitment information**



Motion Pro Armor Coat Cables

- Attractive stainless steel weave with performance and attitude
- Clear Armor Coat protects chrome and painted surfaces
- Premium chrome fittings
- Image is for reference only, actual product may vary
- **Contact MC Advantages for exact fitment information**



Motion Pro Blackout Cables

- Black vinyl housing
- Black fittings
- Image is for reference only, actual product may vary
- Fitment available for most '90-later models
- **Contact MC Advantages for exact fitment information**



Motion Pro Standard Cables

- Standard black vinyl housing with premium chrome fittings
- Meets or exceeds O.E. quality
- Inner nylon sleeve for longer life and smooth operation
- Image is for reference only, actual product may vary
- **Contact MC Advantages for exact fitment information**



MP110041 MP110049 MP110052
 MP110044 MP110050



Motion Pro® Cable Clamps

- Unique two-piece design allows easy installation
- Swivel head design allows more natural cable routing without excessive bending
- Polished chrome finish and innovative single-bolt clamp for a clean custom look

PART	DESCRIPTION	MSRP
MP110052	Cable Clamp, Throttle & Idle	\$9.50
MP110049	Single Cable Holder for ¹⁵ / ₆₄ " , ⁹ / ₃₂ " , ⁵ / ₁₆ " & ¹¹ / ₃₂ " Cables	\$11.90
MP110050	Dual Cable Holder for ¹⁵ / ₆₄ " , ⁹ / ₃₂ " , ⁵ / ₁₆ " & ¹¹ / ₃₂ " Cables	\$14.90
MP110041	Cable Clamps, 1.25"-1.5", Single Throttle/Clutch	\$26.25
MP110043	Cable Clamps, 1"-1.125", Single Throttle/Clutch	\$24.99
MP110042	Cable Clamps, 1.25"-1.5", Dual Throttle/Clutch	\$29.99
MP110044	Cable Clamps, 1"-1.125", Dual Throttle/Clutch	\$28.25

A. Bulletprüf® Hydraulic Clutch Conversion Kit

- Easy-to-install conversion kit for cable-to-hydraulic clutch action
- Includes hand control, banjo bolts, transmission side cover, one-piece pushrod, bearing block, bleed screw (on top), gasket and chrome hardware
- Does not include brake/clutch lines
- Separate BPHCPP pressure plate with sealed bearing is required for fitment with Bulletprüf™ and Primo®

PART	DESCRIPTION	MSRP
Conversion Kits (Controls & Switches Sold Separately):		
BPCK144	Conversion Kit For 5- Or 6-Speed Evolution®	\$199.99
BPCK145	Conversion Kit For 5- Or 6-Speed TC	\$199.99
Switches:		
BP1032C	Bulletprüf™ OEM Switches For '96-Later, Chrome	\$119.99
BP1036B	Bulletprüf™ OEM Switches For '96-Later, Black	\$119.99
BPHCPP	Pressure Plate For Bulletprüf™ OR Primo Belt Drive	\$83.20

B. Bulletprüf® Handlebar Control Kit

Rugged handlebar controls! Comes with chrome levers, housings, master cylinders and cruise control hardware. Now with hydraulic and cable controls.

PART	DESCRIPTION	MSRP
BP2135	Left/Right Controls For '05-Later, 9/16" Brake, 11/16", Clutch, MUST USE DOT4	\$399.99
BP2136	Left/Right Controls For '05-Later, 9/16" Brake, 11/16", Clutch, MUST USE DOT4	\$399.99
BP2131	L/R Controls, 9/16" Brake, 11/16", Clutch For '96-L'04, MUST USE DOT5	\$399.99
BP2132	L/R Controls, 11/16" Brake, 11/16", Clutch For '96-L'04, MUST USE DOT5	\$399.99
BP2133	Kit w/ 9/8" Brake, 11/16" Clutch, '96-Later, DOT 5	\$399.99
BP2031	Complete Cable Kit 9/16" Bore	\$230.00
BP2032	Complete Cable Kit 11/16" Bore	\$230.00

C. Stampede™ Stealth Levers

• Shown in chrome, use "P" or "B" on part number for polished or black anodized

PART	DESCRIPTION	MSRP
Hand Controls For Cable Clutch		
STBHCS200C	Brake Mast. Cyl. & Clutch Cable Perch w/ Levers	\$520.00
STBHCS201C	Brake Master Cylinder w/ Lever, 11/16" Bore, Dual Disc	\$303.00
STBHCS202C	Clutch Cable Perch w/ Lever	\$217.00
STBHCS203C	Brake Master Cylinder w/ Lever, 9/16" Bore, Single Disc	\$303.00
STBHCS111C	Stealth Brake Lever	\$96.00
STBHCS212C	Stealth Clutch Lever	\$96.00
Hand Controls For Hydraulic Clutch		
STBHCS100C	Brake Mast. Cyl. & Clutch Cable Perch w/ Levers	\$606.00
STBHCS101C	Brake Master Cylinder w/ Lever, 11/16" Bore, Dual Disc	\$303.00
STBHCS102C	Clutch Cable Perch w/ Lever	\$303.00
STBHCS103C	Brake Master Cylinder w/ Lever, 9/16" Bore, Single Disc	\$303.00
STBHCS111C	Stealth Brake Lever	\$96.00
STBHCS212C	Stealth Clutch Lever	\$96.00
Switches & Switch Housings		
STBSSH100C	Switch Housing Set, Left & Right w/ Switches	\$413.00
STBSSH100C	One-Piece Housing, Left w/ Switches	\$203.00
STBSSH200C	Two-Piece Housing, Right w/ Switches & Throttle Housing	\$210.00

D. Yankee Engineuity Skeletal Levers

Shown in chrome, use "P" or "B" on part number for polished or black anodized

PART	DESCRIPTION	MSRP
YESL07	Clutch/Brake Lever Set, '82-'95 BT & XL	\$197.95
YESL09	Clutch/Brake Lever Set, '96-'06 BT & XL	\$197.95
YESL05	Single Brake Lever, '82-'95 BT & XL	\$99.50
YESL06	Single Clutch Lever, '82-'95/'02-'06 BT & XL	\$99.50
YESL08	Single Brake Lever, '96-'06 BT & XL	\$99.50





A. GPI Slayer Handlebar Levers

- Billet-cut and chromed levers strike fear into the heart of onlookers
- Caution: these levers are sharp and have looks to KILL

Wrath Levers For:		MSRP
CHC509HC	American IronHorse® One-Hole Design Brake, Pair	\$268.00
CHC514HC	American IronHorse® Two-Hole Design Brake, Pair	\$268.00
CHC509AC	Arlen Ness® Tech Rad II, Pair	Call
CHC504HH	H-D®, '01-Later, Hydraulic, Pair	\$268.00
CHC509HC	H-D®, '96-Later, Cable, Pair	\$268.00
CHC514HC	H-D®, '82-'95, Cable, Pair	\$268.00
CHC504JH	Joker, Hydraulic, Pair	\$268.00
CHC509JC	Joker, Cable, Pair	\$268.00
CHC504PH	PM®, Hydraulic, Pair	\$268.00
CHC905VC	Victory®, '03-Later, Cable, Pair	\$268.00
Torment Levers For:		MSRP
CHC507HC	American IronHorse® One-Hole Design Brake, Pair	\$268.00
CHC512HC	American IronHorse® Two-Hole Design Brake, Pair	\$268.00
CHC502HH	H-D®, '01-Later, Hydraulic, Pair	\$268.00
CHC507HC	H-D®, '96-Later, Cable, Pair	\$268.00
CHC512HC	H-D®, '82-'95, Cable, Pair	\$268.00
CHC502PH	PM®, Hydraulic, Pair	\$268.00
CHC903VC	Victory®, '03-Later, Cable, Pair	\$268.00
Destruction Levers For:		MSRP
CHC510HC	American IronHorse® One-Hole Design Brake, Pair	\$268.00
CHC515HC	American IronHorse® Two-Hole Design Brake, Pair	\$268.00
CHC510AC	Arlen Ness® Tech Rad II, Pair	\$268.00
CHC505HH	H-D®, '01-Later, Hydraulic, Pair	\$268.00
CHC510HC	H-D®, '96-Later, Cable, Pair	\$268.00
CHC515HC	H-D®, '82-'95, Cable, Pair	\$268.00
CHC505JH	Joker, Hydraulic, Pair	\$268.00
CHC505PH	PM®, Hydraulic, Pair	\$268.00
CHC505P2H	PM® Contour, Hydraulic, Pair	\$268.00
CHC906VC	Victory®, '03-Later, Cable, Pair	\$268.00

B. GPI Spear Handlebar Levers

- Show-chromed, billet-cut levers, fitment available for:

CHC506HC	American IronHorse® One-Hole Design Brake, Pair	\$268.00
CHC511HC	American IronHorse® Two-Hole Design Brake, Pair	\$268.00
CHC506AC	Arlen Ness® Tech Rad II, Pair	\$268.00
CHC501HH	H-D®, '01-Later, Hydraulic, Pair	\$268.00
CHC506HC	H-D®, '96-Later, Cable, Pair	\$268.00
CHC511HC	H-D®, '82-'95, Cable, Pair	\$268.00
CHC501JH	Joker, Hydraulic, Pair	\$268.00
CHC506PC	PM®, Cable, Pair	\$268.00
CHC501P2H	PM® Contour, Cable, Pair	\$268.00
CHC901VC	Victory®, '03-Later, Cable, Pair	\$268.00

C. CycleSmiths Wing Levers

- Excellent comfort and easy operation following the natural curve of the fingers
- Bolt-on fits for '82-'95 H-D®, '96-later and late models with hydraulic clutch
- Aluminum construction with triple-plated chrome

PART	DESCRIPTION	MSRP
CY10196	'96-Later, Chromed	\$134.95
CY10196P	'96-Later, Polished	\$119.95
CY10196BP	'96-Later, Black Powdercoat	\$133.25
CY142	'96-Later For Hyd., Chrome	\$173.55
CY101	'82-'95, Chromed	\$124.95
CY101P	'82-'95, Polished	\$99.95
CY101BP	'82-'95, Black Powdercoat	\$124.25



A. Bulletprüf® Grips

- Missile grips offer the ultimate ergonomic feel and shocking show appeal
- Spoon-shaped grips feature rubber inserts for superior grip.
- Fits all models with 1" handlebars on '73-later models, 1" step-down at grip
- Length: 5.75"

PART	DESCRIPTION	MSRP
BPGM601	Missile (Billet)	\$99.99
BPGT603	Spiral (Die Cast)	\$99.99
BPGS602	Straight (Cast)	\$99.99
BPFM602	Missile Foot Pegs	\$99.99
BPGP631	Perf Grips, Chrome	\$99.99



B. Gateye Customs Acrylic Grips

- Available with chrome billet aluminum ends as pairs
- Colored acrylic shroud is available in red or black
- Matching foot/toe pegs and Stampede™ Forward Controls

PART	DESCRIPTION	MSRP
CEGBS	Billet Aluminum w/ Black Acrylic Shroud	\$208.83
CEGRS	Billet Aluminum w/ Red Acrylic Shroud	\$208.83



C. Stampede™ Billet Grips

- Complement to the popular selling Stampede™ Forward Controls

PART	DESCRIPTION	MSRP
STBGRS100P	Roller Grip Set, Polished	\$99.99
STBGRS500P	Lancer Grip Set, Polished	\$99.99
ST7004	3 O-Ring Set, Polished	\$165.00
ST7005	3 O-Ring Set, Chrome	\$165.00
ST7005B	3 O-Ring Set, Black Anodized	\$165.00
STBGRS600P	NiteStick Grip Set, Polished	\$99.99



D. Stampede™ Throttle Housing



- Get your bars as comfortable and clean as possible!
- Grip not included



PART	DESCRIPTION	MSRP
ST7002	Throttle Housing, Chrome	\$77.00
ST7002B	Throttle Housing, Black Anodized	\$82.00

E. Stampede™ Rear Foot Pegs

- Complement to the popular selling Stampede™ Forward Controls
- Billet and chrome construction

PART	DESCRIPTION	MSRP
ST100	3 O-Ring Peg, Polished, 2-Pack	\$80.00
STBRPS100P	Roller Rear Peg, Polished, 2-Pack	\$80.00
STBRPS500P	Lancer Rear Peg, Polished, 2-Pack	\$80.00
STBRPS600P	NiteStick Rear Peg, Polished, 2-Pack	\$80.00
STBRPS700P	Aftermath Rear Peg, Polished, 2-Pack	\$80.00

Use B For Black; C For Chrome



PART	DESCRIPTION	MSRP
STBRC100P	Elite Rear Clevis Set, Polished	\$47.00
ST02400	Standard Female Clevis, 3/8"-16, Billet	\$43.00

Use B For Black; C For Chrome

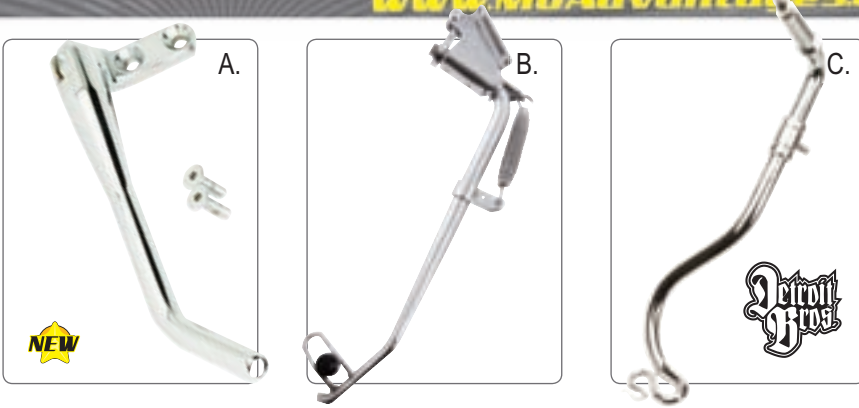

A. Bulletpruf® Builder's Kickstand

- Custom, clean super duty kickstand
- Stock length

PART	DESCRIPTION	MSRP
BPKS20	Kickstand w/ Internal Spring, 2-Hole Style	\$79.99

B. Bulletpruf® Kickstand

- High strength spring made of heat-treated steel for long life
- Length is 1" under stock.
- The 4-speed stand ships disassembled, 5-speed ships fully assembled
- Includes upgraded leg stop with adjustable set screw

PART	DESCRIPTION	MSRP
BPKS00	Kickstand For 4-Speed BT, Standard Length	\$79.99
BPKS12	Kickstand For 5-Speed Softail®, 1" Under Length	\$79.99

C. Detroit Bros.® Devil's Tongue Kickstand

- Forged in the depths of hell itself out of mild steel
- Be the first one on the block to own one

PART	DESCRIPTION	MSRP
DBKS1	Kickstand For '86-'05 Softail®, Chrome	\$249.99



D. Stampede™ Floorboard Shift Kit

- Kit widens the open space between toe and heel shifter levers for comfort
- Allows for positive shifting with no binding or shifting past the shift point, which puts less stress on the linkage making it easier to find neutral
- Requires front shifter bracket to install — for bikes with a center stand, only the heel shift can be used

PART	DESCRIPTION	MSRP
STSL1	Shift Kit, '94-Later FL w/ Lower Leg Fairings	\$249.00
STSL2	Shift Kit, '94-Later FL w/o Lower Leg Fairings	\$249.00
STSL3	Shift Kit, '94-Later FL, Rear Heel Shift Only	\$289.00



E. Wicked Image Toe Shifters for FL Models

- Constructed from 6061-T6 billet — rubber o-rings are provided for the peg

PART	DESCRIPTION	MSRP
WZ3001	Flame Toe Shifter For '90-'08 FL, Chrome	\$214.99
WZ3002	Skull Flame Toe Shifter For '90-'08 FL, Chrome	\$214.99
WZ3003	Tribal Toe Shifter For '90-'08 FL, Chrome	\$214.99
WZ3004	Gothic Toe Shifter For '90-'08 FL, Chrome	\$199.99



F. - G.

Combine with
**Suicide-Free
 Shift Kit,**
 For Safer Shifting
 See Drivetrain Section



H.

F. Grandeur Cycle® Jockey Shift

- Available with authentic 8 ball, cue ball or 13 ball knob on a 3/8"-16 end
- Premium polished stainless steel rod ends
- Fits all Evolution® applications
- Replaces top motor mount
- Available to fit 4- and 5-speed models

PART	DESCRIPTION	MSRP	PART	DESCRIPTION	MSRP
Jockey Shifter, 5/6-Speed w/:			Jockey Shifter, 4-Speed w/:		
GRJS8B	8 Ball Knob	\$695.00	GRJS48B	8 Ball Knob	\$695.00
GRJS13B	8 Ball Knob	\$695.00	GRJS413B13	13 Ball Knob	\$695.00
GRJSCB	Cue Ball Knob	\$695.00	GRJS4CB	Cue Ball Knob	\$695.00

G. Grandeur Cycle® Graba Fistful Jockey Shift

- Triple chrome-plated billet shifter w/ linkage rods
- | | | |
|-------|--|----------------|
| GRABA | Graba Fistful Jockey Shift Kit, Chrome | MSRP: \$849.00 |
|-------|--|----------------|

I. LED Lighted Shift Knobs

- The eyes can flash in slow flash, quick flash or alternating patterns

PART	DESCRIPTION	MSRP
MSSKSNC	Cursed Serpent Knob, Red LED Eyes, Chrome	\$19.99
MSSKSC	Evil Skull Knob, Red LED Eyes, Chrome	\$19.99
MSSKSG	Evil Skull Knob, Blue LED Eyes, Gold	\$19.99

A. Stampede™ Three-Band Billet Forward Controls

- Radius mill design with bearings instead of bushings for smooth operation
- Brake lines install in the back side of the master cylinder for a clean look
- Comes assembled using chrome hardware and band-type pegs
- Installation hardware not included — sold separately

PART	DESCRIPTION	MSRP
ST001	'86-'99 Softail®, Stock Length, Polished	\$429.00
ST002	'86-'99 Softail®, Stock Length, Chrome	\$569.00
ST003	'86-'99 Softail®, 2" Extension, Polished	\$429.00
ST004	'86-'99 Softail®, 2" Extension, Chrome	\$569.00
ST020	'00-'06 Softail®, Stock Length, Polished	\$429.00
ST021	'00-'06 Softail®, Stock Length, Chrome	\$569.00
ST022	'00-'06 Softail®, 2" Extension, Polished	\$429.00
ST023	'00-'06 Softail®, 2" Extension, Chrome	\$569.00
ST005	'82-'94 FXR, Polished	\$429.00
ST006	'82-'94 FXR, Chrome	\$569.00
ST016	'82-'94 FXR 2" Extension, Polished	\$429.00
ST017	'82-'94 FXR 2" Extension Chrome	\$569.00
ST007	'91-Later Dyna™, Polished	\$429.00
ST008	'91-Later Dyna™, Chrome	\$569.00
ST018	'91-Later Dyna™, 2" Extension, Polished	\$429.00
ST019	'91-Later Dyna™, 2" Extension, Chrome	\$569.00
ST100	Rear Foot Pegs, Polished	\$85.00
ST101	Rear Foot Pegs, Chrome	\$127.00

Add B To Polished Part #'s For Black Anodized Finish

B. Stampede™ Single-Band Billet Forward Controls

FOR '86-'99 Softail®

ST001S	Polished, Single Band Pegs, Folding	\$429.00
ST003S	Polished, Single Band Pegs, Folding, 2" Ext.	\$429.00
ST002S	Chrome, Single Band Pegs, Folding	\$569.00
ST004S	Chrome, Single Band Pegs, Folding, 2" Ext.	\$569.00
ST001SB	Black Ano, Single Band Pegs, Folding	\$569.00
ST003SB	Black Ano, Single Band Pegs, Folding, 2" Ext.	\$569.00

For '00-'06 Softail®

ST020S	Polished, Single Band Pegs, Folding	\$429.00
ST022S	Polished, Single Band Pegs, Folding, 2" Ext.	\$429.00
ST021S	Chrome, Single Band Pegs, Folding	\$569.00
ST023S	Chrome, Single Band Pegs, Folding, 2" Ext.	\$569.00
ST020SB	Black Ano with , Single Band Pegs, Folding	\$569.00
ST022SB	Black Ano, Single Band Pegs, Folding, 2" Ext.	\$569.00

Foot Pegs

ST100S	Polished, Single Band, Folding	\$85.00
ST101S	Chrome, Single Band, Folding	\$127.00
ST100SB	Black Ano, Single Band, Folding	\$127.00

Add B To Polished Part #'s For Black Anodized Finish

C. Stampede™ Billet Forward Controls w/ Acrylic Pegs

- Well proven control bodies with an ultra-durable black or red acrylic shell over 6061 polished billet aluminum cores
- Pegs have rubber o-rings for effective grip
- Rear pegs available, contact MC Advantages for details
- Add F To Polished Part #'s For Folding Pegs

PART	DESCRIPTION	MSRP
FOR '86-'99 Softail®		
STCR01	Polished, Red Acrylic Foot & Toe Pegs	\$599.99
STCR03	Polished, Red Acrylic Foot & Toe Pegs, 2" Extended	\$599.99
STCB01	Polished, Black Acrylic Foot & Toe Pegs	\$599.99
STCB03	Polished, Black Acrylic Foot & Toe Pegs, 2" Extended	\$599.99
STCR01B	Black Ano, Red Acrylic Foot & Toe Pegs	\$699.99
STCR03B	Black Ano, Red Acrylic Foot & Toe Pegs, 2" Extended	\$699.99
STCB01B	Black Ano, Black Acrylic Foot & Toe Pegs	\$699.99
STCB03B	Black Ano, Black Acrylic Foot & Toe Pegs, 2" Extended	\$699.99
For '00-Later Softail®		
STCR20	Polished, Red Acrylic Foot & Toe Pegs	\$599.99
STCR22	Polished, Red Acrylic Foot & Toe Pegs, 2" Extended	\$599.99
STCB20	Polished, Black Acrylic Foot & Toe Pegs	\$599.99
STCB22	Polished, Black Acrylic Foot & Toe Pegs, 2" Extended	\$599.99
STCR20B	Black Ano, Red Acrylic Foot & Toe Pegs	\$699.99
STCR22B	Black Ano, Red Acrylic Foot & Toe Pegs, 2" Extended	\$699.99
STCB20B	Black Ano, Black Acrylic Foot & Toe Pegs	\$699.99
STCB22B	Black Ano, Black Acrylic Foot & Toe Pegs, 2" Extended	\$699.99



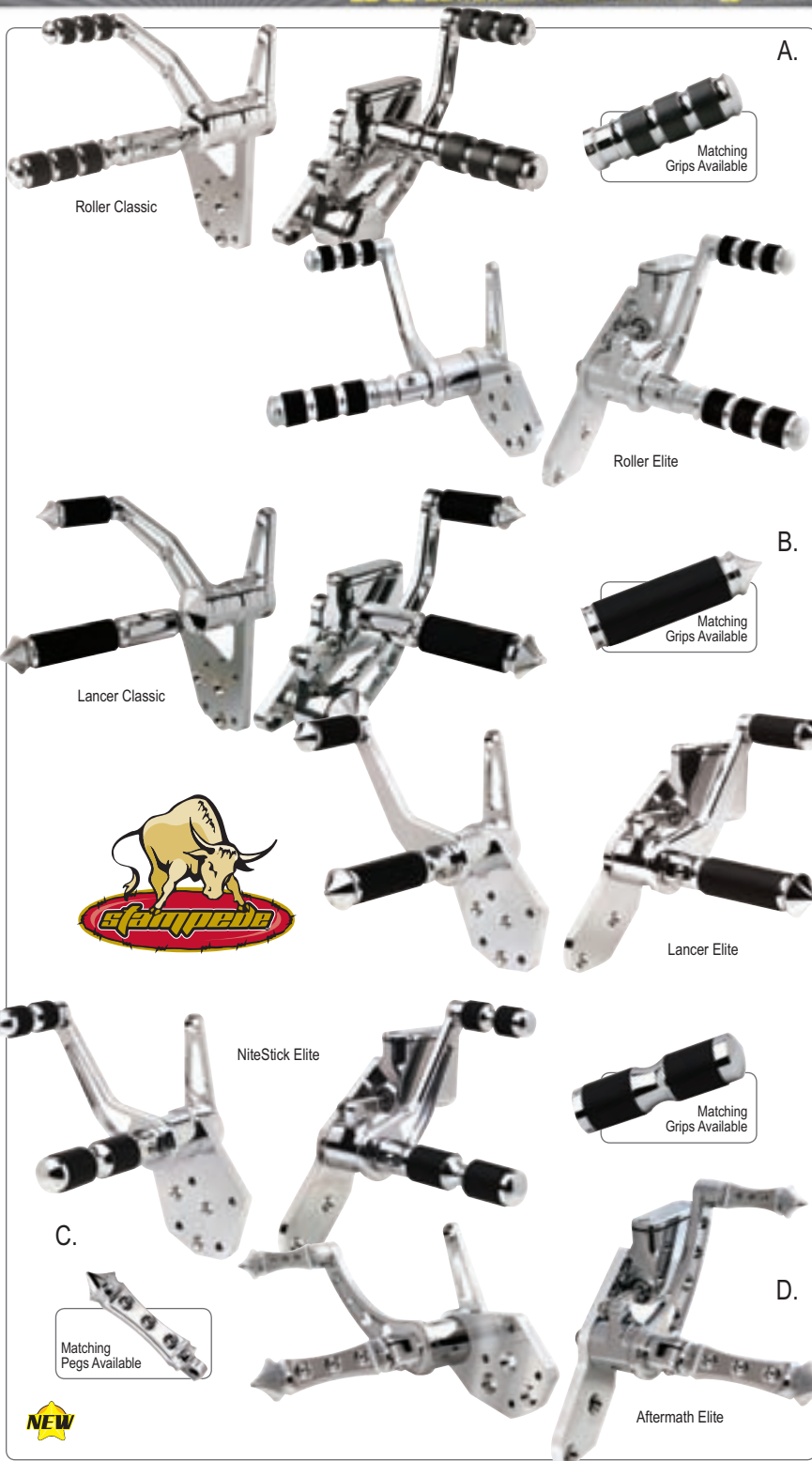

A. Stampede™ Roller Forward Controls

- Side port master cylinder to accommodate hidden brake line
- Custom toe pegs and folding foot pegs with UV resistant rubber
- Does not include brake line or shift linkage

PART	DESCRIPTION	MSRP
STBFC100P	Roller Classic For '86-'99 FXST, Polished	\$639.00
STBFC101P	Roller Classic For '00-Later FXST, Polished	\$639.00
STBFC102P	Roller Classic For Dyna®, Polished	\$639.00
STBFC103P	Roller Classic For FXR, Polished	\$639.00
STBFCHT300P	Roller Elite For '86-'99 FXST, Polished	\$568.00
STBFCHT301P	Roller Elite For '00-Later FXST, Polished	\$568.00
STBFCHT302P	Roller Elite For Dyna®, Polished	\$568.00
STBFCHT303P	Roller Elite For FXR, Polished	\$568.00

Use B For Black; C For Chrome; 2 For 2" Extended; 3 For 3" Extended

B. Stampede™ Lancer Forward Controls

- Side port master cylinder to accommodate hidden brake line
- Custom toe pegs and folding foot pegs with UV resistant rubber
- Does not include brake line or shift linkage

PART	DESCRIPTION	MSRP
STBFC300P	Lancer Classic For '86-'99 FXST, Polished	\$639.00
STBFC301P	Lancer Classic For '00-Later FXST, Polished	\$639.00
STBFC302P	Lancer Classic For Dyna®, Polished	\$639.00
STBFC303P	Lancer Classic For FXR, Polished	\$639.00
STBFCHT500P	Lancer Elite For '86-'99 FXST, Polished	\$568.00
STBFCHT501P	Lancer Elite For '00-Later FXST, Polished	\$568.00
STBFCHT502P	Lancer Elite For Dyna®, Polished	\$568.00
STBFCHT503P	Lancer Elite For FXR, Polished	\$568.00

Use B For Black; C For Chrome; 2 For 2" Extended; 3 For 3" Extended

C. Stampede™ NiteStick Forward Controls

- Side port master cylinder to accommodate hidden brake line
- Custom toe pegs and folding foot pegs with UV resistant rubber
- Does not include brake line or shift linkage

PART	DESCRIPTION	MSRP
STBFCHT600P	NiteStick Elite For '86-'99 FXST, Polished	\$568.00
STBFCHT601P	NiteStick Elite For '00-Later FXST, Polished	\$568.00
STBFCHT602P	NiteStick Elite For Dyna®, Polished	\$568.00
STBFCHT603P	NiteStick Elite For FXR, Polished	\$568.00

Use B For Black; C For Chrome; 2 For 2" Extended; 3 For 3" Extended

D. Stampede™ Aftermath Forward Controls

- Side port master cylinder to accommodate hidden brake line
- Custom toe pegs and folding foot pegs with UV resistant rubber
- Does not include brake line or shift linkage

PART	DESCRIPTION	MSRP
STBFCHT700P	Aftermath Elite For '86-'99 FXST, Polished	\$568.00
STBFCHT701P	Aftermath Elite For '00-Later FXST, Polished	\$568.00
STBFCHT702P	Aftermath Elite For Dyna®, Polished	\$568.00
STBFCHT703P	Aftermath Elite For FXR, Polished	\$568.00

Use B For Black; C For Chrome; 2 For 2" Extended; 3 For 3" Extended

E. Bulletprüf® Flamed Forward Controls

- Billet cut flamed arms and missile pegs to match the available missile grips
- Provides the extra control needed for your ride
- Ships unassembled — mounting hardware is included
- Fits '84-'99 Softail®

PART	DESCRIPTION	MSRP
BPFC	Forward Controls w/ Master Cylinder	\$650.00

F. Grandeur Cycle® Hydraulic Brake & Clutch Controls

- Hydraulic brake and foot clutch forward controls with lustrous chrome finish
- Fit 10mm banjo bolts w/ 11/16" bore master cylinders on pre-'00 models
- Match with the Auto Clutch, to ride to a stop clutch-free!

PART	DESCRIPTION	MSRP
GRFHC	3-Band Hydraulic/Hydraulic Forward Controls	\$895.00

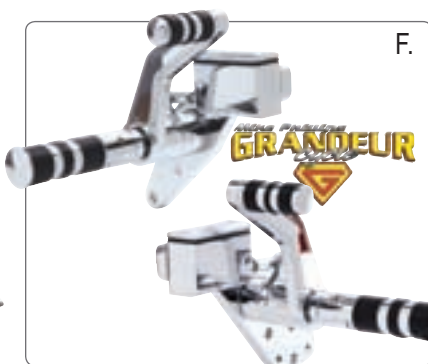



A. Bulletpruf® Slipstream Mirror & Stem
 This mirror and stem are perfect for adding a fluid look to a bike.
 Features a curved back in a 3 wood golf club style.
 BPMS601S Slipstream Mirror Unit, Pair \$99.99



B. Bulletpruf® Chrome Mirrors (Stems Sold Separately)

Bulletpruf™ chrome mirrors are sold in pairs. **Stems sold separately.**

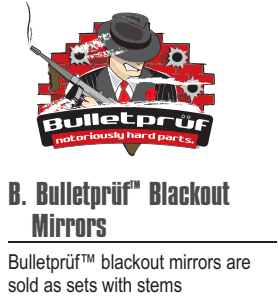

B. Bulletpruf™ Blackout Mirrors

Bulletpruf™ blackout mirrors are sold as sets with stems



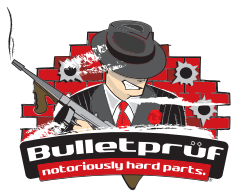

Bulletpruf™ Mirror Stems

Bulletpruf™ stems are sold in pairs. Mirrors sold separately.

Skull Flame BPSFS \$38.29



Tribal BPS566 Call



Slotted BPS548 Call



Devil's Tail BPPTS \$54.99



Flame Lick BPFLS \$54.99

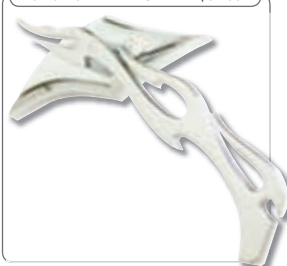

Streamline Set BPSS \$54.99



Demon BPDMS \$54.99

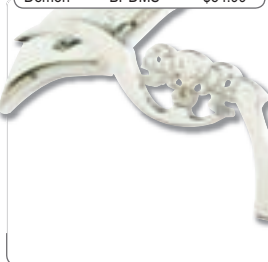

Diamond BPDS \$54.99

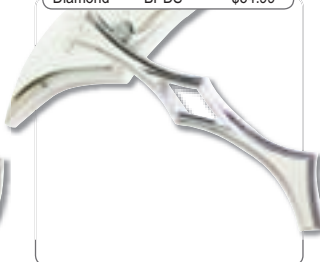

Trucker Girl BPHS \$54.99

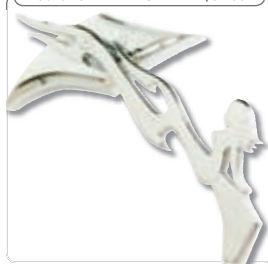

Maltese BPMS \$54.99

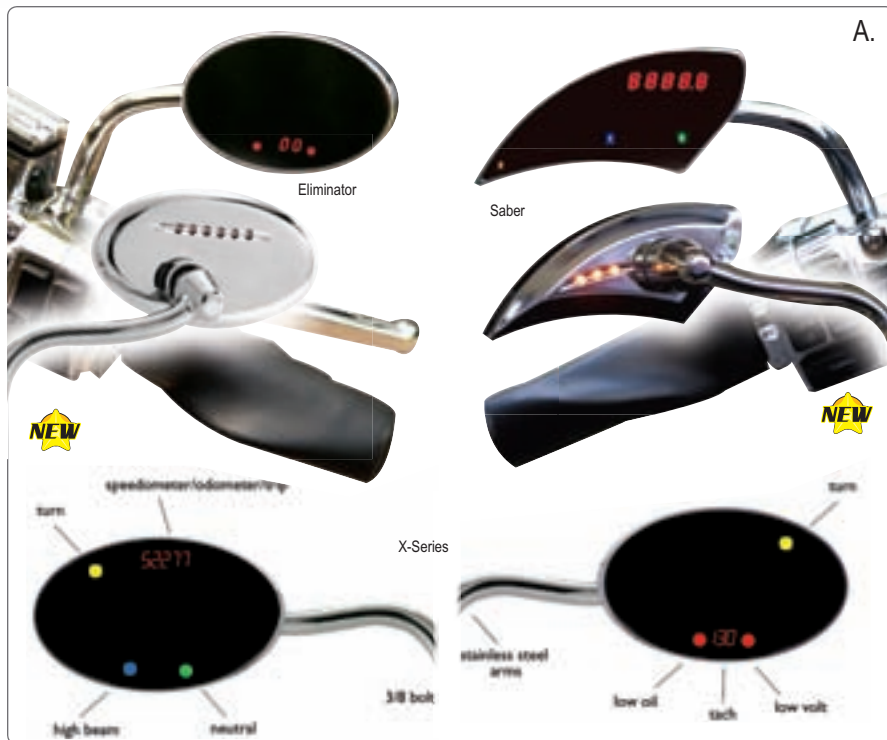
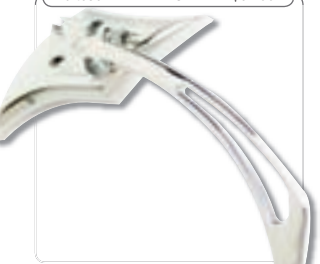

A. Maximum Mirrors With Integrated Gauges & Lighting

- Chrome billet housings with standard or twisted .5" stainless steel stems
- Premium stainless steel and nylon pivot assembly, extremely durable
- Sold in pairs

PART	DESCRIPTION	MSRP
Mirrors w/ Integrated Digital Speedometer, Odometer, Trip & Tachometer		
BLMSLE5S	Slimline w/ Standard Arm	\$699.00
BLMSLE5T	Slimline w/ Twisted Arm	\$699.00
BLMELIMS	Eliminator w/ Standard Arm	\$699.00
BLMELIMT	Eliminator w/ Twisted Arm	\$699.00
BLMSABRS	Saber w/ Standard Arm	\$699.00
BLMSABRT	Saber w/ Twisted Arm	\$699.00
X-Series Mirrors w/ Integrated Digital Speedometer, Odometer, Trip & Tachometer, Neutral, Hi-Beam, Low Voltage, Low Oil		
BLMSLE5XS	Slimline X w/ Standard Arm	\$770.00
BLMSLE5XT	Slimline X w/ Twisted Arm	\$770.00
BLMELIMXS	Eliminator X w/ Standard Arm	\$770.00
BLMELIMXT	Eliminator X w/ Twisted Arm	\$770.00
BLMSABRXS	Saber X w/ Standard Arm	\$770.00
BLMSABRXT	Saber X w/ Twisted Arm	\$770.00

PART	DESCRIPTION	MSRP
XD-Series Mirrors w/ Integrated Digital Speedometer, Odometer, Trip & Tach, Neutral, Hi-Beam, Low Voltage, Low Oil, PLUS Directional Indicators		
BLMSLE5XDS	Slimline XD w/ Standard Arm	\$799.00
BLMSLE5XDT	Slimline XD w/ Twisted Arm	\$799.00
BLMELIMXDS	Eliminator XD w/ Standard Arm	\$799.00
BLMELIMXDT	Eliminator XD w/ Twisted Arm	\$799.00
BLMSABRXDS	Saber XD w/ Standard Arm	\$799.00
BLMSABRXDT	Saber XD w/ Twisted Arm	\$799.00

PART	DESCRIPTION	MSRP
D-Series Mirrors w/ Integrated Directional Indicators, Yellow LED		
BLMDME5S	Slimline D w/ Standard Arm	\$398.00
BLMDME5T	Slimline D w/ Twisted Arm	\$398.00
BLMDMSABS	Saber D w/ Standard Arm	\$398.00
BLMDMSABT	Saber D w/ Twisted Arm	\$398.00



B. Wicked Image Talon Mirror Set

- Billet Arm w/ Forged Mirror Housing, Chrome

PART	DESCRIPTION	MSRP
WZ2001	Tribal Arm w/ Talon Mirror, Left Side	\$109.95
WZ2002	Tribal Arm w/ Talon Mirror, Right Side	\$109.95
WZ2003	Gothic Arm w/ Talon Mirror, Left Side	\$109.95
WZ2004	Gothic Arm w/ Talon Mirror, Right Side	\$109.95



C. Maximum Under-Mirror Turn Signals

- Sequential super bright red or yellow LED or non-sequential red

PART	DESCRIPTION	MSRP
BLTSTSDR	Sequential, Red	\$168.95
BLTSTSDY	Sequential, Yellow	\$168.95
BLTNSTDR	Non-Sequential, Red	\$168.95
BLM516X25	Directional Mounting Bolts, Under Mirror Applications. For Badlands Digital Mirrors	\$64.50
BLMB51624	Directional Mounting Bolts, Direct To Mirror Applications. For stock or custom mirrors with male threaded stem	\$24.25

A. Crime Scene Choppers® "Rapide" Headlight

- A new look from your grandpa's era!
- Uses standard 4.5" sealed beam headlamp (not included) or the Crime Scene Choppers triple-lamp Laser Light (available separately)
- Includes body, polished brass grill, wiring harness, mounting block and all stainless hardware

PART	DESCRIPTION	MSRP
CSC702	Satin Finish w/ Highlights & Polished Brass Grille	\$299.00
CSC703	Chrome	\$299.00

B. Detroit Bros.® Menace Headlight

- T6 aluminum
- Single high-intensity spot lamp
- Run vertically or horizontally
- Custom applications only
- Mounting block included

PART	DESCRIPTION	MSRP
DBHM	Menace Headlight, Polished Only	\$249.99

C. JBN Custom Phantom Headlight

- Distinctive new design with uncompromising quality at an affordable price
- The DOT approved light features an H-4, high beam/low beam bulb
- Aluminum housing boasts a triple chrome plated finish
- Stock under mounted fitment, accepts .75" mounting brackets

PART	DESCRIPTION	MSRP
JBN168	Phantom Headlight Assembly	\$195.00

D. Adjure® Smooth Bucket Headlight Housings

- Chrome die cast aluminum headlight housings come in 5 3/4" & 7" diameters
- Complete with a one-bulb harness, pinch bolt, mounting block, nuts and washers

PART	DESCRIPTION	MSRP	PART	DESCRIPTION	MSRP
Ventura Buckets			Sunset Buckets		
AHB51010	5 3/4" Smooth	\$285.95	AHB51210	5 3/4" Smooth	\$285.95
AHB71010	7" Smooth	\$307.95	AHB51211	5 3/4" Smooth w/ Visor	\$299.95
AHB54010	5 3/4" Flamed	\$285.95	AHB54211	5 3/4" Flamed w/Visor	\$359.95
AHB74010	7" Flamed	\$354.95			
Call For Additional Adjure® Models					

E. Adjure® Spotlights & Head Lamps

- DOT approved headlamps with great looks and safer lighting
- Call for additional fitments

PART	DESCRIPTION	MSRP
AT40111	4 1/2" Ice Spotlight (Pair)	\$89.90
AT40311	4 1/2" Trillient Lamp (Pair)	\$129.95
AT40611	4 1/2" Diamond Spotlight (Pair)	\$99.95
AT50100	5 3/4" Ice Lamp	\$71.95
AT50400	5 3/4" Wave Lamp	\$84.95
AT50100SR	5 3/4" Diam. Cut Skull Lamp	\$99.95
AT70100	7" Ice Lamp	\$69.95
AT70300	7" Trillient Lamp	\$99.95
AT70400	7" Wave Lamp	\$99.95
AT70100SR	7" Diamond Cut Skull Lamp	\$109.95
AT70X00A	7" Iron Cross Head Lamp w/ Bulb Cover, Chrome	\$99.95
AT70X00ASR	7" Iron Cross Head Lamp w/ Skull Bulb Cover, Chrome	\$109.95





A.



B.

A. Crime Scene Choppers® Laser Light

- Fits the new Rapide headlight and most 4.5" headlight housings
- Uses three high intensity sealed lamps for 100 watts on low beam, 175 on high!

PART	DESCRIPTION	MSRP
CSC707	Laser-Light, 4.5", Three Bulbs, 175 Watts	\$99.00

B. Detroit Bros.® LED Brake Light Pod

An American-made LED light made from aircraft-quality aluminum. Includes red LED brake light and lens for hardware only.

PART	DESCRIPTION	MSRP
DBTL1	Light Pod, 1.875" L x 1.5" Diameter	\$119.99



C.

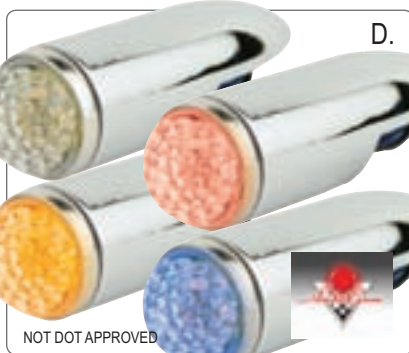

D.

C. Auto Gem® Baby Bullet LED Lights

- Cool accents and safety to your ride.
- Overall size of 1 1/8" diam. x 2 1/4", including a 1" mounting stud
- Includes LED light source with amber or clear lens

PART	DESCRIPTION	MSRP	PART	DESCRIPTION	MSRP
Chrome Housing			Black Powdercoat Housing		
AG382277	Amber, Amber Lens	\$140.00	AG330529	Amber, Amber Lens	\$140.00
AG382278	Amber, Clear Lens	\$140.00	AG330537	Amber, Clear Lens	\$140.00
AG330813	Blue Dot, Clear Lens	\$140.00	AG330539	Blue Dot, Clear Lens	\$140.00
AG382275	Red, Red Lens	\$140.00	AG330538	Red, Clear Lens	\$140.00
AG382276	Red, Clear Lens	\$140.00	AG330536	Red, Red Lens	\$140.00

D. Auto Gem® Derringer LED Lights

- Increases visibility and lends bikes a great nostalgic look
- Made exclusively for '84-Later Softail® and '58-'81 Big Twins
- Notched out to fit on the end of the strut for a really clean look
- Allows the rider unobstructed use of detachable hardware for sissy bars and bags

PART	DESCRIPTION	MSRP	PART	DESCRIPTION	MSRP
Chrome			Black Powdercoat		
AG330804	Amber, Clear Lens	\$125.00	AG330542	Amber, Clear Lens	\$125.00
AG340131	Blue Dot, Clear Lens	\$125.00	AG330544	Blue Dot, Clear Lens	\$125.00
AG330279	Red LED & Red Lens	\$125.00	AG330543	Red, Clear Lens	\$125.00
AG330803	Red, Clear Lens	\$125.00	AG330551	Red, Red Lens	\$125.00

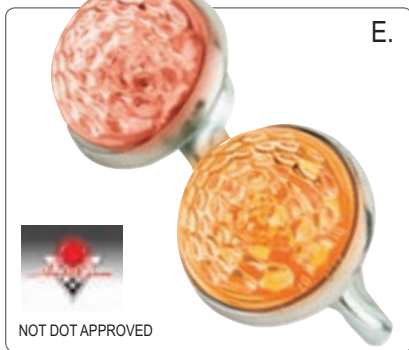

E.

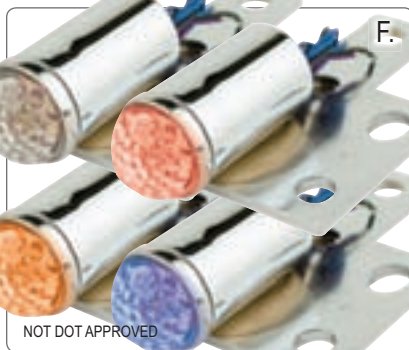

F.

E. Auto Gem® Power Jewel LED Grip Lights/Replacement Bulbs

- 12 LED's inside a 1" glass to upgrade halogen Shotgun or Derringer lights
- Can also fit in the end of handlebars using a 7/8" rubber expansion plug
- Features dual function running light and super bright turn signals

PART	DESCRIPTION	MSRP	PART	DESCRIPTION	MSRP
AG320238	Red, Red Lens	\$75.00	AG320237	Amber, Amber Lens	\$75.00
AG330801	Red, Clear Lens	\$75.00	AG330802	Amber, Clear Lens	\$75.00
AG330601	Blue Dot, Clear Lens	\$75.00	AG381646	Rubber Plug	\$5.99

F. Auto Gem® Shotgun LED Lights

- Eliminate the stock license plate bracket while retaining fender and saddlebag support.
- Fits '89-later FLH & Road King® as well as '92-later Road Glide®
- Convert to a lay-down fender mount license plate like Auto Gem's® Lowdown Deluxe
- Replace rear fender and saddlebag support system on '92-later FLHT

PART	DESCRIPTION	MSRP	PART	DESCRIPTION	MSRP
AG330807	Amber, Clear Lens	\$125.00	AG340143	Red LED & Lens	\$125.00
AG330806	Amber LED & Lens	\$125.00	AG330805	Red, Clear Lens	\$125.00
AG330808	Blue Dot, Clear Lens	\$125.00	AG382998	Plug & Play Harness	Call



G.

G. Adjure® Bullet Beacon Lights & Mounts

- LED's last longer, run cooler, draw less current and are brighter than halogens
- When using LED's, install a load equalizer due to low current draw

PART	DESCRIPTION	MSRP
AANS119233	Red LED, Chrome	\$209.95
ANS119333	Amber LED, Chrome	\$209.95
ANS12016A	Amber Lens, Halogen, Chrome	\$139.95
ANS13516R	Red Lens, Halogen, Chrome	\$139.95
ANS15016C	Clear Lens, Halogen, Chrome	\$139.95
ANSFB39K	Bullet Light Brackets For 39mm Tube, Chrome	\$109.95
ANSFB49K	Bullet Light Brackets For 49mm Tube, Chrome	\$109.95
ANSFB41K	Bullet Light Brackets For 41mm Tube, Chrome	\$129.95
ANSM002	Bullet Side Plate Mount, Chrome	\$99.95
ANSSAMO	Bullet Swingarm Mount, Chrome	\$129.95



Crime Scene Choppers "Rapide" Taillight

- A new look from your grandpa's era!
- Includes 48 LED stop/run lamp, 3-bolt mount base

PART	DESCRIPTION	MSRP
CSC704	Satin Finish w/ Highlights & Polished Brass Grille	\$199.00
CSC705	Chrome	\$229.00

A. Bulletprüf® Diamond Taillight/License Plate Frame

Diamond Taillight/License Plate Frame with LED lighting and red lens. Chrome finish aluminum. Choose separate mounting bracket below unless noted.

PART	DESCRIPTION	MSRP
BP121LH	Flat, Horizontal, Left	\$159.99
BP121RH	Flat, Horizontal, Right	\$159.99
BP121R	Convex, Vertical, Right	\$169.99
BP121LN	Concave, Vertical, Left (Axle Mount Included)	\$189.99

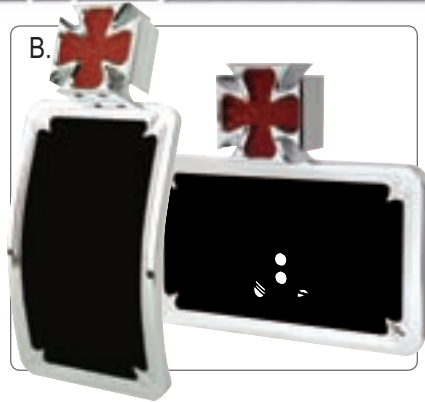
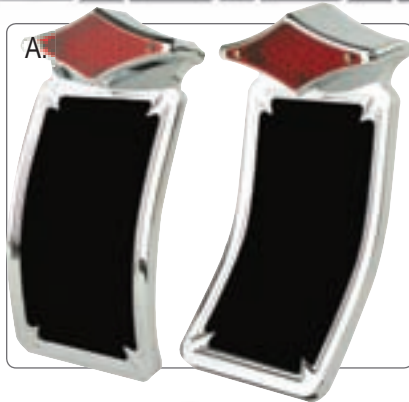

B. Bulletprüf® Iron Cross Taillight/License Plate Frame

Iron Cross Taillight/License Plate Frame with LED lighting and red lens. Chrome finish aluminum. Choose separate mounting bracket below.

PART	DESCRIPTION	MSRP
BPICLH	Flat, Horizontal, Left	Call
BPICRH	Flat, Horizontal, Right	\$159.99
BPICL	Flat, Vertical, Left	\$159.99
BPICRR	Convex, Vertical, Right	\$179.99
BPICR	Flat, Vertical, Right	\$159.99
BPICRL	Concave, Left	\$179.99

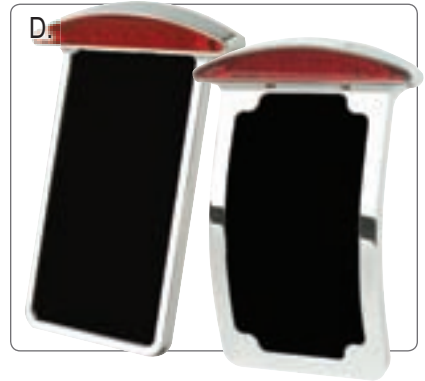

C. Bulletprüf® Cat Eye Taillight/License Plate Frame

Cat Eye Taillight/License Plate Frame with LED lighting and red lens. Chrome finish aluminum. Choose separate mounting bracket below.

PART	DESCRIPTION	MSRP
BP12105L	Taillight/License Plate, Convex, Left	\$179.99

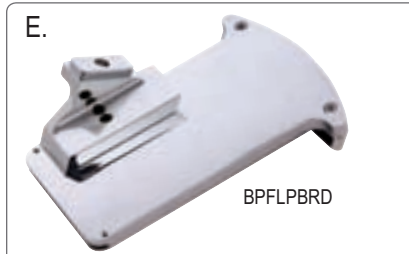

D. Bulletprüf® Half Moon Taillight/License Plate Frame

Halfmoon Taillight/License Plate Frame with LED lighting and red lens. Chrome finish aluminum. Choose separate mounting bracket at right.

PART	DESCRIPTION	MSRP
BP102L	Convex, Vertical, Left	\$169.99
BP122R	Convex, Vertical, Right	\$169.99
BP122RH	Horizontal, Right	\$159.99

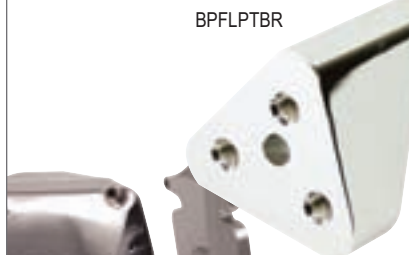

E. Bulletprüf® License Plate Brackets

Chromed billet aluminum brackets available for Bulletprüf® Taillight/License Plate Frames to enclosed primary, fender-top or axle-mount installations.

PART	DESCRIPTION	MSRP
BPFLPBRP	Flat License Bracket, Primary-Mount	\$55.47
BPFLTBR	Flat License Bracket, Fender-Mount	\$18.49
BPFLPBR	Flat License Bracket, Right/Left Side, For Softail®	\$46.22
BPCLPBR	Convex Curved License Plate Bracket, Universal	\$69.99
BPFLPBRD	Flat License Plate Bracket For Dyna®	\$65.92
BPFLPBRB	Convex Curved License Bracket For BDL/Primo	\$65.92

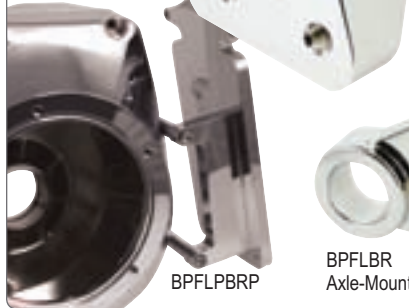

F. Crime Scene Choppers Taillight/License Plate Frame

- Chromed steel side-mount license plate and tail light mount for Rapide taillight
- Includes chrome tag bracket, plain steel weld-on tabs and stainless steel hardware
- Rapide taillight sold separately

PART	DESCRIPTION	MSRP
CSC706	Side-Mount For Rapide, Chrome	\$99.99

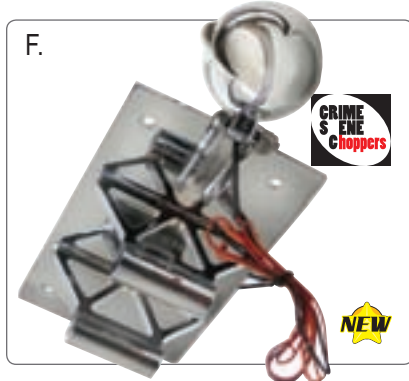

G. L.A. County Choprods® License Plate Frame

L.A. County Choprods® has used the "Stop Here" license plate mount/tail light on many of its custom builds and on TV's Build or Bust™.

PART	DESCRIPTION	MSRP
LATLFH	Horizontal, Black	\$169.00
LATLFV	Vertical, Black	\$169.00



H. Maximum License Plates With Integrated Turn Signals

- For 4 x 7 inch plate come in chrome

PART	DESCRIPTION	MSRP
BLPSTSPR	Sequential LED, Red	\$168.95
BLPSTSPY	Sequential LED, Yellow	\$168.95
BLPNSTSPR	Non-Sequential LED, Red	\$168.95





A. All-In-One Light Controller Module

- Eliminates all electronic control modules, including the starter relay
- Simplifies wiring saving space, time and money
- Self cancelling signals can act as flashers
- Turn signals that can also act as brake lights
- Brake light flashes three times before steady state
- Battery saver kills lights when starting
- Includes hi/lo beam controller
- Will work with with A.R.S.E., see this section

PART	DESCRIPTION	MSRP
BELC	Systems/Light Controller	\$315.00

B. Badlands Illuminator Pro: Run, Brake & Turn Module

- Control every feature within a single system.
- Automatic canceling turn signals, running lights, brake lights
- Built-in load equalizer, quick lane change mode and an emergency flash mode
- Fits customs and H-D® without self cancelling turn signals

PART	DESCRIPTION	MSRP
BLILLP	Badlands Illuminator Pro	\$118.95

C. Badlands Illuminators: Run, Brake and Turn Lights

- Converts turn signals into running lights, brake lights and turn signals
- Built-in load equalizer — runs stock turn signals and small aftermarket lights

PART	DESCRIPTION	MSRP
BLILL1	Original For '73-'84 FX, FL, XL & Customs, No Plugs	\$99.95
BLILL1A	Plug-In For 6-Pin '85-'96 FLH, '86-'95 Softail®/FXR, '95-'96 Dyna®, '86-'98 XL; Security System Compatible	\$118.95
BLILL1B	Plug-In For '97-Later FLH, '96-Later Softail®/Deuce®, '97-Later Dyna®, '99-'03 XL; Security System Compatible	\$118.95
BLILL1C	Plug-In For '04-Later XL; Security System Compatible	\$118.95



C. Illuminator Modules



B. Illuminator Pro



D. Turn Signal Shut-Off Modules



E. Load Equalizer Modules

D. Badlands Automatic Turn Signal Shut-Off Modules

- Upgrade H-D® or customs without the '91-later self-canceller
- Features auto-canceling nine second flashing, lane change quick cancel, emergency flasher mode, built-in load equalizer and solid state flasher

PART	DESCRIPTION	MSRP
BLATS3A	10-Pin Amp-Style Plug-In For Many '87-'93 H-D®	\$83.95
BLATS3B	8-Pin Deutsch-Style Plug-In For Many '94-Later H-D®	\$94.95
BLATS3C	12-Pin Deutsch-Style Plug-In For Many '94-Later H-D®	\$94.95

E. Badlands Load Equalizers

- Designed to return amperage draw to the correct factory specs when aftermarket marker lights are used to replace stock turn signals
- Use in place of a heavy duty flasher on early model bikes when small marker lamps with wedge bulbs are being used as turn signals
- **BLLE2** adds the ability to retain emergency flashers without heat build-up
- **BLLE3** will run emergency flashers for any amount of time — the only load equalizer designed for parade use — it can also correct many erratic turn signals

PART	DESCRIPTION	MSRP
BLLE1	Load Equalizer I For '91-'99 H-D® & Customs	\$26.95
BLLE2	Load Equalizer II For '91-'99 H-D® & Customs	\$34.95
BLLE3	Load Equalizer III For '91-Later H-D® & Customs Using LED	\$69.95

F. Wire Plus Headlight Control Module

- High/low latching, to make a momentary push button latch from high to low beam as a stock switch — unit is 1" x 1.25" x .5"

PART	DESCRIPTION	MSRP
WP142	Headlight Control Module	\$75.00

G. Wire Plus Lighting Control Module

- Auto-cancel circuit makes rear signals into running/brake lights and turn signals
- One-wire hook-up — unit is 2" x 1.25" x .5"
- Provides load equalization and separate wires for side mount tail and brake light

PART	DESCRIPTION	MSRP
WE143	Lighting Control w/ Auto Cancel Turn & Load Equalizer	\$112.19



Other Wire Plus Part Listings

MC Advantages distributes the entire line of Wire Plus products. See MCAdvantages.com for pricing of additional popular components not shown here, including: • Automotive style start kits • Coil covers • Motor mount Systems • Twin Cam Ignition harnesses • Auto cancel turn signal w/ load equalizer • High/low latching modules • Mid-frame systems

Z1 Mid-Frame Systems:	MSRP
WE179 Mini w/ Comp Rel. & Light Module	\$396.84
WE191 Mini w/ Or w/o Turns & Auto Cancel	\$325.09
WE192 Mini w/ Minimal Switches, w/ Or w/o Turns	\$325.09
WE182 Stock w/ Comp Rel. & Light Module	\$416.59
WE181 Stock Controls w/ Lighting Module	\$402.85
Motor Mount Systems	
WE130 For Stock Switches w/ Or w/o Turn & Auto-Cancel	\$520.83
WE131 For Minimal Switches w/ Or w/o Turns	\$520.83
WE139 Billet Top Motor Mount, Up To 100"	\$160.71
WE140 Billet Top Motor Mount, Over 101"	\$160.71
Automotive-Style Start Harnesses	
WE105 Chopper Style Kit w/ Harness	\$226.64
WE107 Start Kit w/o Harness	\$160.26

Misc. Modules	
WE141 Auto Cancel Turn Signal w/ Load Eq.	\$91.46
WE142 High-Low Latching Module	\$41.61
WE145 Auto Cancel Turn Signal, DOT Approv.	\$112.19
WE161 4 Button Switch Control Module w/ Lighting Control & Load Equalizer	\$201.46
WE166 Dual Latching Module For High/Low And Off/Run	\$75.00
WE168 Motor Mount System For Stock Controls w/ Lighting Module	\$608.97
Automotive-Style Start Systems	
WE115 Housing & Ignition Switch Only	\$187.73
WE116 w/ Hidden Switches, No Turns	\$511.90
WE117 w/ Hidden Switches & Standard Turns	\$520.83
WE178 w/ Hidden Switches & Lighting Module	\$608.97



Wire Harnesses For Twin Cam With:

WE136 Stock Ign., All Sensor Connections	\$81.44
WE137 Aftermarket Ignition Module	\$81.44
WE169 Aftermarket Ignition & Data Link	\$81.44

ENGINE
FUEL SYSTEMS
EXHAUST
ELECTRICAL
DRIVETRAIN
WHEELS
SUSPENSION
SHEETMETAL
FRAMES
CONTROLS
LIGHTING
BAGGERS
TOOLS
APPAREL

A. Yankee Engineuty Tach/Speedo Gauge Cups

- For 1.9" Micro and 2 5/8" Mini gauges in electronic or mechanical versions
 - Fits VDO, OEM, Dakota Digital®, Auto Meter® and RevTech®
 - Please confirm all gauge cups by specific diameter size before ordering.
- See [MC Advantages.com](http://MCAdvantages.com) For A Complete List Of Fitments



B. Yankee Engineuty Tach/Speedo Bases

- For '74-later risers, '88-later Springers® and Deuce®, as well as for 1", 1.25" and 1.5" T-Bars — universal fitment also available.
 - Various overall shapes, with or without LED lights and light holes
 - Cups are available for specific OE fitment include LED light bars and harness
- See [MC Advantages.com](http://MCAdvantages.com) For A Complete List Of Fitments



C. Yankee Engineuty Gauge Tops

- For 1.9" Micro gauges and 2 5/8" Mini gauges in single or double configurations
 - Also available as 3 3/8" size singles or teamed with a 1.9" Micro gauge
 - Fits VDO, OEM, Dakota Digital®, Auto Meter® and RevTech®
 - Yankee gauge tops fit on Yankee or Road King® base clamps
 - Please confirm all gauge cups by specific diameter size before ordering
- See [MC Advantages.com](http://MCAdvantages.com) For A Complete List Of Fitments

D. Yankee Engineuty Gauge Top To Motor Mount Adapter

- Gauge top adapter for Yankee gauge tops to most Yankee motor mounts
- For the YEMM0304/05/06/07/09/10/11

PART	DESCRIPTION	MSRP
YEGA01	Gauge Top Adapter To Motor Mount, Chrome	\$83.95

E. Yankee Engineuty Slimline Base Clamps

- Tach/Speedo Base For 1" Bars w/ Separate Risers
- Gauge top adapter for Yankee gauge tops to most Yankee motor mounts
- For the YEMM0304/05/06/07/09/10/11

PART	DESCRIPTION	MSRP
YEB22	Tach/Speedo Base w/ No Indicator Lights	\$117.79
YEB23	Tach/Speedo Base w/ 4 Indicator Lights	\$121.98

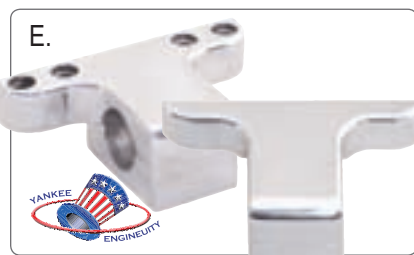
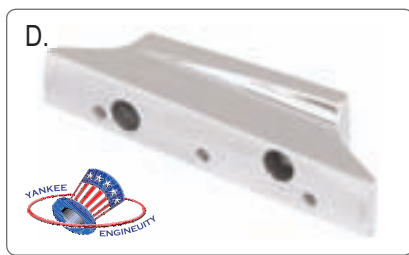

F. CPI Rocker Box Gauge Mounts & Gauge Cup

- Single or dual cup chromed billet brackets with chromed gauge cups
- The single cup size is 2.25" deep with a 2.25" OD and a 1.9" ID
- Larger gauges can be used without cup — cup hole size in mount is 2.050" ID
- For dual gauge unit, the second cup is 1.5" ID to receive oil pressure gauge
- Mounting bolt hole spread is 3".
- Fits S&S®, Ultima™, TP Engineering® rocker boxes — now includes fitment for H-D® Evolution®

Smooth Billet w/ Cups, Chrome	MSRP
CHBGM501 Single Mount	\$221.63
CHBGM505E Single Mount, Evolution®	\$221.63
CHBGM503 Double Mount	\$277.02
CHBGM507E Double Mount, Evolution®	\$277.02
Flamed Billet w/ Cups, Chrome	
CHBGM502 Single Mount	\$243.63
CHBGM506E Single Mount For Evolution®	\$243.63
CHBGM504 Double Mount	Call
CHBGM508E Double Mount For Evolution®	\$304.55



G. Stampede™ Billet Rocker Box Gauge Mounts

- Polished billet aluminum

PART	DESCRIPTION	MSRP
STGSMT1	Speedo Mount For TC, 2.0625" Gauges	\$59.99
STGSMT2	Speedo Mount For TC, 2.625" Gauges	\$59.99
STGSMOT1	Gauge Bracket For TC, 2.0625" Speedo & 1.625" Oil	\$79.99
STGSMOT2	Gauge Bracket For TC, 2.625" Speedo & 1.625" Oil	\$79.99
STGSMSC1	Speedo Mount For Evolution®, 2.0625" Gauges	\$59.99
STGSMSC2	Speedo Mount For Evolution®, 2.625" Gauges	\$59.99
STGSMOSC1	Gauge Bracket For Evolution®, 2.0625" Speedo, 1.625" Oil	\$79.99
STGSMOSC2	Gauge Bracket For Evolution®, 2.625" Speedo, 1.625" Oil	\$79.99

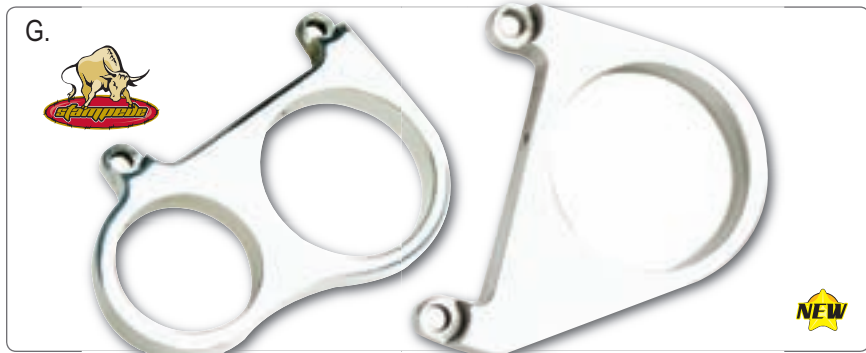



A.



B.



C.



D.



E.



F.

A. Dakota Digital® Dash-Mount Speedo/Tach For Fat Bob®

- Speed/tach/gear position in MPH or KPH models
- Full complement of indicators, contact MC Advantages for details
- Universal mounting design will adapt to both newer and older style dash panels
- **Two year limited warranty!**

PART	DESCRIPTION	MSRP
DDH2002	For Pre-'04 Fat Bob®	\$489.95
DDH2004	For '04-Later Fat Bob®	\$489.95

B. Dakota Digital® Round Gauges

- 199 or 225 MPH speedometers with optional quick response bar graph tachometers, odometers with dual trip meters and a full complement of indicators
- Full complement of indicators, contact MC Advantages for details
- Front bezel with non-glare, scratch-resistant lens, machined aluminum housing

PART	DESCRIPTION	MSRP
DDH3013	Mini Speedometer 2 1/16", MPH	\$274.95
DDH3015	Mini Graphic Speed/Tach/Indicators 2 1/16", MPH & KPH	\$469.95
DDH3016	Speed/Tach/Indicators 3 3/8", MPH & KPH	\$314.95

C. Dakota Digital® 7000 Series Rectangle Gauges

- Readouts include speedo, bar graph tach, oil pressure gauge and more
- **Two year limited warranty!**

PART	DESCRIPTION	MSRP
DDMCV7100	Oval, Speed/Tach/Oil Pres./Fuel/Voltage	\$499.95
DDMCV7200	Spike, Speed/Tach/Oil Pres./Fuel/Voltage	\$499.95
DDMCV7300	Hooded, Speed/Tach/Oil Pres./Fuel/Voltage	\$599.95
DDMCV7400	Classic, Speed/Tach/Oil Pres./Fuel/Voltage	\$499.95

D. Dakota Digital® Gear Indicators

- Displays 1-7 forward gears, including neutral
- Simple programming for any application
- **Use on any bike with an electronic speed signal**
- Chromed machined aluminum housing, built-in mounting bracket
- **Two year limited warranty!**

PART	DESCRIPTION	MSRP
DDPGR1100	Programmable Gear Indicator Readout for 1" Bars	\$225.00
DDPGR1125	Programmable Gear Indicator Readout for 1.25" Bars	\$225.00

E. Dakota Digital® Retro & Standard Gauges

- 0-255 MPH speedometer, odometer and trip odometer
- High-brightness blue display offers excellent sunlight readability
- **Two year limited warranty!**

PART	DESCRIPTION	MSRP
DDMCL4013R	Speedo w/ Odometer & Trip, Retro, 1 7/8" LED	\$259.95
DDMCL4013S	Speedo w/ Odometer & Trip, Standard, 1 7/8" LED	\$259.95
DDMCL4014R	Speedo w/ Odometer & Trip, Retro, 1 7/8" LED (KPH)	\$259.95
DDMCL4014S	Speedo w/ Odometer & Trip, Standard, 1 7/8" LED (KPH)	\$259.95
DDMCL4027R	Tachometer, Retro, 1 7/8" LED	\$259.95
DDMCL4027S	Tachometer, Standard, 1 7/8" LED	\$259.95
DDMCL4032R	Oil Pressure Gauge, Retro, 1 7/8" LED	\$189.95
DDMCL4032S	Oil Pressure Gauge, Standard, 1 7/8" LED	\$189.95
DDMCL4111R	Head Temp Gauge, Retro, 1 7/8" LED	\$219.95
DDMCL4111S	Head Temp Gauge, Standard, 1 7/8" LED	\$219.95

F. Dakota Digital® Six Gauge Packages For Baggers

- Complete six gauge set plugs directly into the stock wiring
- Fits '06-later fairing models including Road Glide®
- Includes speedometer with odometer and dual trip meters, tachometer, oil pressure, oil temperature, voltage, and fuel level gauges
- Additional features include clock, gear position, 0-60 time, 1/4 mile time, 1/4 mile per hour, 0-60 MPH, high speed and RPM recall
- Includes cruise on and cruise engaged indicators as well as security and check engine lights
- Extremely bright blue LED displays are highly viewable in sunlight!

PART	DESCRIPTION	MSRP
DDMCL3006OT	For '06-Later Bagger Models	\$1,165.00
DDMCL3000OT	For '96-'05 Bagger Models	\$1,165.00

G. Electronic Hidden Antenna

- Designed to perform as well as a standard rod antenna with no external rod or aerial
- Can be hidden inside fairings
- Plugs and plugs directly into standard antenna jack
- Requires 12VDC
- Sealed against moisture and dirt
- 3.5" x .75" w/ 3' cable
- Not designed to receive weather band or CB

PART	DESCRIPTION	MSRP
DDANT2000	Electronic Hidden Antenna	\$79.95



G.

ENGINE
FUEL SYSTEMS
EXHAUST
ELECTRICAL
DRIVETRAIN
WHEELS
SUSPENSION
SHEETMETAL
FRAMES
CONTROLS
LIGHTING
BAGGERS
TOOLS
APPAREL

A. Pro Cycle® Gauges By AutoMeter

- Vibration and water resistant
- One, two and half-pulse signal capability
- Fit H-D®, BDL and others
- Gauges have cobalt blue backlit dials and red lighted pointers
- Chrome cups and bezels
- Cups have 2 1/16" diameter
- Mounting brackets are available separately
- Note: '04-later H-D® require tach signal pickup or ignition with tach output. Gauges are for custom mount applications only

PART	DESCRIPTION	MSRP	PART	DESCRIPTION	MSRP
Tachometers, 2 5/8", 8,000 RPM			Speedometer, 2 5/8" 120 MPH		
A419306	Black	\$215.33	A419340	Black	\$197.69
A419307	White	\$209.57	A419341	White	\$199.27
A419308	Chrome	\$222.59	A419342	Chrome	\$211.88
A419309	Chrome Flames	\$216.55	A419343	Chrome Flames	\$224.54



B. Wire Plus Rectangular Speedometers

- Speedometer, bar graph tachometer, trip, odometer and all indicator light
- No external brainbox
- Repels moisture while staying vibration and corrosion resistant
- Requires digital signal from transmission sensor for speedo and an ignition module with tach output

PART	DESCRIPTION	MSRP
WE124	Bar Mount Digital/Bar Graph Tach, 2" x 3.35"	\$520.78
WE125	Panel Mount Digital/Bar Graph Tach, 2" x 3.35"	\$520.78
Mounting Brackets & Bracket Clamps		
WE126	Bracket w/ Clamp, 1" Bars	\$102.86
WE127	Bracket w/ Clamp, 1 1/4" Bars	\$102.86
WE128	Bracket, 1 1/2" Bars	\$102.86
WE129	Bracket, Tab-Mount, 1 1/8" Spacing	\$51.56
WE150	Pedestal w/ Backplate, 1" Bar	\$91.46
WE151	Clamp w/ Backplate, 1" Bar	\$91.46

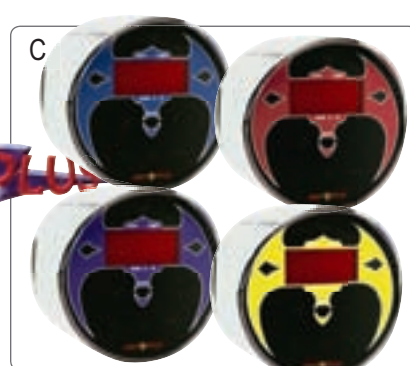
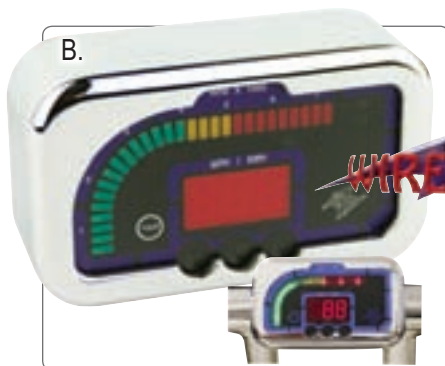

C. Wire Plus Round Speedometers

- Speedometer, tachometer, trip, odometer and all indicator light functions
- Moisture, vibration and corrosion resistant
- No external brainbox is required
- Super-bright display for true daylight readability with auto-dimming at night
- Requires digital signal from the transmission sensor for speedo and an ignition module with tach output.

PART	DESCRIPTION	MSRP
WE184	Red, T-Bar Mount, 1"	\$498.51
WE177	Red, Riser Mount, 1"	\$498.51
WE172	Red, T-Bar Mount, 1 1/4"	\$498.51
WE188	Red, T-Bar Mount, 1 1/2"	\$498.51
WE185	Blue, T-Bar Mount, 1"	\$498.51
WE173	Blue, Riser Mount, 1"	\$498.51
WE174	Blue, T-Bar Mount, 1 1/4"	\$498.51
WE189	Blue, T-Bar Mount, 1 1/2"	\$498.51
WE186	Yellow, T-Bar Mount, 1"	\$498.51
WE175	Yellow, Riser Mount, 1"	\$498.51
WE176	Yellow, T-Bar Mount, 1 1/4"	\$498.51
WE190	Yellow, T-Bar Mount, 1 1/2"	\$498.51
WE183	Violet, T-Bar Mount, 1"	\$498.51
WE154	Violet, Riser Mount, 1"	\$498.51
WE153	Violet, T-Bar Mount, 1 1/4"	\$498.51
WE187	Violet, T-Bar Mount, 1 1/2"	\$498.51



A.R.S.E. Security System

Eliminate the need for an ignition switch. Brings the bike to life — only you can simply sit on the bike to start it. A credit card sized transponder activates the A.R.S.E.!

- Hands free operation, get on the bike and ride
- Prevents lost keys, codes, locks and stress
- Millions of ID combinations, no chance of theft
- No ignitions or wiring fried while washing
- Works well with motorcycle light controller

BEARSE A.R.S.E. Ass Recog. System \$495.00
BELC Systems/Light Controller \$315.00

F.

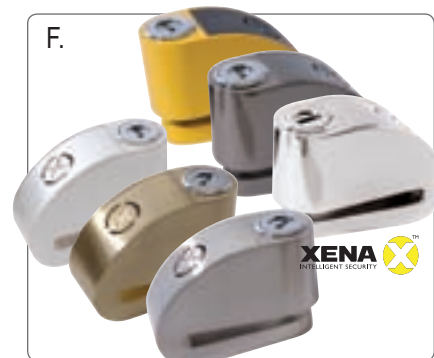

F. Xena Security Alarm Lock

One product, two security systems. The lock: A solid block of hardened steel with double locking pins. Laser cut keys make the lock virtually pick-proof. The alarm: powered by a self arming, maintenance-free microchip, it features a 110 DB siren triggered by shock and/or motion

GRXR1C	Chrome	\$99.95
GRXR1G	Gold	\$99.95
GRXR1GM	Gun Metal	\$99.95
GRXR1PW	Pearl White	\$99.95
GRXR1SS	Stainless Steel	\$99.95
GRXR1Y	Yellow	\$99.95

E. Cyclone Security System

- Ear-piercing 120 dB durations of 10 or 30 seconds when warning
- Engine immobilizer prevents starting by three different methods
- Automatically arms five minutes after ignition is turned off
- Silent mode kills full siren blast but allows warning and confirmation chirps
- Panic siren is easily activated with transmitter to alert others in an emergency
- Sector bypass system prevents the siren from becoming a nuisance
- Manual disarm allows rider to disarm without a transmitter, simply by turning the ignition key the same number of times as your secret code

PART	DESCRIPTION	MSRP
CL866F	Cyclone Security System	\$229.99
CLCSP	Cyclone Security System Pager	\$109.99





MCC

ADVANTAGES

BAGGERS

A. S&S® V107T Complete Touring Special Engines

Carbureted, fits '84-'99 chassis. EFI fits '95-'98 FI chassis. All engines come completely assembled with Super E carburetor or Magneti Marelli®-Style VFI Module, chrome die-cast rocker boxes, electronic compression releases, billet tappet guides, gearcover, S&S® oil filter, spark plugs and Mobil 1® motor oil.

PART	DESCRIPTION	MSRP
SS319480	Carbureted, Natural w/ Super Stock® Ignition	\$5,995.00
SS319479	Carbureted, Natural w/ IST Ignition	\$6,410.00
SS319482	Carbureted, Black w/ Super Stock® Ignition	\$6,320.00
SS319481	Carbureted, Black w/ IST Ignition	\$6,735.00
SS319484	Carbureted, S&S® Polished w/ Super Stock® Ignition	\$7,095.00
SS319483	Carbureted, S&S® Polished w/ IST Ignition	\$7,510.00
SS1060786	Single-Bore EFI, Natural w/ VFI Module	\$7,140.00
SS1060787	Single-Bore EFI, Black Finish w/ VFI Module	\$7,465.00
SS1060788	Single-Bore EFI, S&S® Polished w/ VFI Module	\$8,240.00

VFI Fuel Systems

SS165135	Single Bore EFI Manifold	\$119.95
SS170498	VFI Single Bore Teardrop Induction Kit, Chrome	\$199.95
SS170497	VFI Single Bore Desperado Induction Kit, Chrome	\$199.95
SS171001	VFI Single Bore Tuned Induction Runner Kit, Natural	\$239.95
SS171003	VFI Single Bore Tuned Induction Runner Kit, Black	\$259.95
SS171005	VFI Single Bore Tuned Induction Runner Kit, Chrome	\$324.95
SS171047	Single Bore Tuned Induction Bracket Kits	\$374.95

B. S&S® Stainless Performance Oval (SPO™) Mufflers

- Many compare the exhaust note of the standard SPO to the pleasing low rumble of a late '60s muscle car — but at a reasonable volume that is not likely to get the neighbors upset
- Makes as much power as much louder competitive performance mufflers
- Avoid covering the bike's audio system!
- A high temperature flat black powdercoat material capable of withstanding the exhaust temperatures of an S&S T124 engine was applied to the baffle flange — this hides soot, keeping the exhaust looking cleaner
- For even a little quieter, but with more power than the stock exhaust, the separate accessory baffle will reduce the noise by about 3 dB
- S&S® 80 db SPO™ Mufflers meet the EPA 80 db drive-by test requirements
- Testing at S&S with an otherwise stock 2007 FLHTC showed these new mufflers to not only be quiet, but to provide a boost in power at the same time
- Note: S&S 80dB SPO mufflers may not conform to EPA standards if installed on a vehicle with a modified engine
- Mufflers are tamper proof in accordance with EPA regulations

PART	DESCRIPTION	MSRP
SS1060116	Standard SPO Mufflers	\$594.95
SS1060117	Quiet Baffle For Standard SPO Mufflers	\$149.95
SS556634	80 dB SPO Mufflers	\$694.95

C. S&S® Quick Set Up Kit

- A quick 10 horsepower for not a lot of money!
- Contains a pair of S&S performance mufflers, an S&S teardrop air cleaner, and a jet kit for carbureted models
- No engine work to do — everything needed is included in the kit!
- Kits for '07-Later models do not include jet kits
- Make more power by making it easier to get air into the engine with either a high flowing S&S teardrop air cleaner or the new single throat tuned induction system
- Also makes it easier for exhaust to exit through low restriction mufflers
- Kits with the single bore tuned induction system provide an added kick due to the increased filter area and the effect of the tuned induction

	PART	MSRP	PART	MSRP
Kits w/ SPO Mufflers For:				
'95-'06 Carb/'02-'07 FI Baggers	Teardrop Air Cleaner	\$839.95	Tuned Induction	\$1,354.95
	SS1061019		SS556507	

D. Hooker® Exhaust For Baggers

PART	DESCRIPTION	MSRP
HK27624	'07-Later 96"+, 49-State, True Dual, Slash Cut, Chrome	\$1,010.20
HK27724	'07-Later 96"+, 49-State, True Dual, Turn-Out, Chrome	\$1,010.20

Tuned Flow® Slip-Ons

These Systems Work With OE Pipes Only

HK27640	Straight-Cut, '85-'94 FL	\$520.23
HK27642	Straight-Cut, '95-'05 FL	\$520.23
HK27641	Slash-Cut, '85-'94 FL	\$520.23
HK27643	Slash-Cut, '95-'05 FL	\$520.23

A.

107"

TOURING POWER!

S&S

New S&S® Engine Warranties w/ S&S Ignitions

120"+ Engine w/ IST Ignition or Delphi®-Style VFI..... 2 years
 120"+ Engine w/ Super Stock® Ignition or Magneti Marelli®-Style VFI..... 1 year
 Up To 119" Engine w/ IST Ignition or Delphi®-Style VFI..... 3 years
 Up To 119" Engine w/ Super Stock® Ignition or Magneti Marelli®-Style VFI.... 2 years
 MC Show-Polished Engines.....2 year upgrade available

B.

SPO™ MUFFLERS!

S&S

C.

S&S

SS556507 For Baggers

D.

Hooker



A. Martin Bros.® Bag Daddy Exhaust Pipes

- These fully-shielded 2.25" pipes merge into a 3.5" stock-mount pipe
- Punched out 10.2 more HP and 9 more ft. lbs. out of a stock '07 touring model

For LSD '86-Later Bagger Models Unless Noted		MSRP
MB028P	Chrome	\$799.99
MB028PB	Ceramic Black	\$799.99

B. Progressive Suspension AirTail® I.A.S. Shocks

The revolutionary AirTail® System from Progressive® is now available to big bike riders, because the folks on Softails® can't have all the fun! Using the same AirTail® concept, I.A.S. (Inertia Active System) incorporate a coil spring system with a dual chambered air shock for totally independent control of both ride firmness and height. This helps improve handling performance by separating wheel and chassis movement. I.A.S. is the shock for performance and looks!

Combine your I.A.S. with the other AirTail® controls and pump options below for the absolute best in custom looks and clean controls.

PART	DESCRIPTION	MSRP
PS7401001C	I.A.S. Unit For '97-Later FLH	\$1,029.95
PS7401002C	I.A.S. Unit For Dyna®	\$1,319.00
PS7401003C	I.A.S. Unit, 12.5"	\$1,358.57

Compressor Kits For AirTail® I.A.S.		MSRP
30-5102	Compressor Kit For '97-Later FLH	\$735.42

C. Hi-Lo Rider Adjustable Shocks For Baggers & Road King®

- All the same great features as the fitments for Softail®, with fitment for Road King® and side-mount baggers
- Remote key fob kit sold separately

PART	DESCRIPTION	MSRP
HLRKP	For Road King® & Side Mount Baggers, Polished	\$995.00
HLRKC	For Road King® & Side Mount Baggers, Chrome	\$1095.00
HLRC	Remote Control Key Fob Kit For Hi-Lo	\$250.00

D. Stampede™ Floorboard Shift Kit

- Kit widens the open space between toe and heel shifter levers for comfort
- Allows for positive shifting with no binding or shifting past the shift point, which puts less stress on the linkage making it easier to find neutral
- Requires front shifter bracket to install — for bikes with a center stand, only the heel shift can be used

PART	DESCRIPTION	MSRP
STSL1	Shift Kit, '94-Later FL w/ Lower Leg Fairings	\$249.00
STSL2	Shift Kit, '94-Later FL w/o Lower Leg Fairings	\$249.00
STSL3	Shift Kit, '94-Later FL, Rear Heel Shift Only	\$289.00

E. Wicked Image Toe Shifters For FL Models

- Constructed from 6061-T6 billet
- Rubber o-rings are provided for the pegs

PART	DESCRIPTION	MSRP
WZ3001	Flame Toe Shifter For '90-'08 FL, Chrome	\$214.99
WZ3002	Skull Flame Toe Shifter For '90-'08 FL, Chrome	\$214.99
WZ3003	Tribal Toe Shifter For '90-'08 FL, Chrome	\$214.99
WZ3004	Gothic Toe Shifter For '90-'08 FL, Chrome	\$199.99

F. Hell's Foundry Slotted Billet Shift Linkages For FL



- Billet aluminum ball-milled pattern shift linkage
- Fits all FL Touring models
- Complete with stainless steel threaded ends and installation instructions
- Polished to a high gloss and anodized for durability

PART	DESCRIPTION	MSRP	PART	DESCRIPTION	MSRP
HFFLSLPA	Polished	\$89.95	HFFLSLCA	Copper Ano	\$89.95
HFFLSLBA	Blue Ano	\$89.95	HFFLSLPPA	Purple Ano	\$89.95
HFFLSLGA	Gold Ano	\$89.95	HFFLSLRA	Red Ano	\$89.95

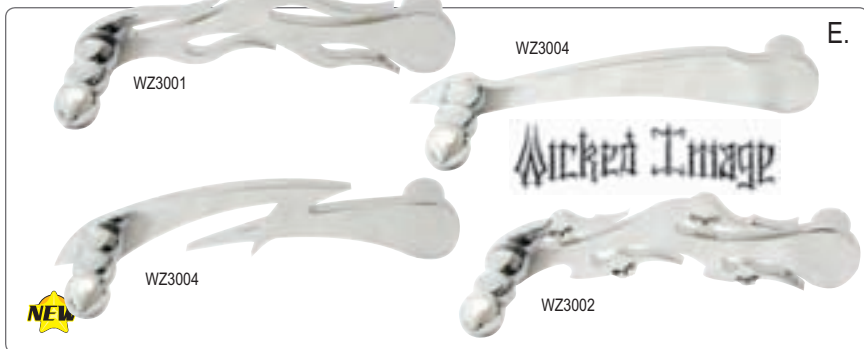

ENGINE
 FUEL SYSTEMS
 EXHAUST
 ELECTRICAL
 DRIVETRAIN
 WHEELS
 SUSPENSION
 SHEETMETAL
 FRAMES
 CONTROLS
 LIGHTING
 BAGGERS
 TOOLS
 APPAREL



WIDE TIRE KITS FOR FLH

A. FBI™ 200-300mm Wide Tire Kits For FLH

- Transform any FLH model into a real road hog.
- Features a swingarm, axle, primary spacer, unpainted/ready for paint fiberglass fender, Avon® 200 tire, stainless steel brackets, tranny offset, gasket kit, and hardware.
- **Premium chrome wheel available separately unless noted**
- 1 1/8" upgrade belt required for '96-'03 FLH installs
- **'08-Later Kits require FB2008 pulley upgrade kit***

PART	DESCRIPTION	MSRP
FB200C08	'08-Later FLH, Wheel Included, Chrome Swingarm*	\$3,899.95
FB200C08NW	'08-Later FLH, No Wheel, Chrome Swingarm*	\$3,199.95
FB200B08NW	'08-Later FLH, No Wheel, Black Swingarm*	\$2,899.95
FB200B08	'08-Later FLH, Wheel Included, Black Swingarm*	\$3,599.95
FB2008	Pulley Upgrade For '08 FLH 200mm Fat Bagger Kits	\$169.95
FB200C07	'07 FLH, Wheel Included, Chrome Swingarm	\$3,899.95
FB200C07NW	'07 FLH, No Wheel, Chrome Swingarm	\$3,199.95
FB200B07NW	'07 FLH, No Wheel, Black Swingarm	\$2,899.95
FB200B07	'07 FLH, Wheel Included, Black Swingarm	\$3,599.95
FBH200CL	'02-'06 FLH Kit, Chrome Spacer, Black Swingarm	\$3,720.95
FBH200CLC	'02-'06 FLH Kit, Chrome Spacer, Chrome Swingarm	\$4,025.95
FBH200SL	'02-'06 FLH Kit, Silver Spacer, Black Swingarm	\$3,595.95
FBH200SLC	'02-'06 FLH Kit, Silver Spacer, Chrome Swingarm	\$3,895.95
FBH200BL	'02-'06 FLH Kit, Black Spacer, Black Swingarm	\$3,595.95
FBH200BLC	'02-'06 FLH Kit, Black Spacer, Chrome Swingarm	\$3,895.95
FBH200C	'97-'01 FLH Kit, Chrome Spacer, Black Swingarm	\$3,720.95
FBH200CC	'97-'01 FLH Kit, Chrome Spacer, Chrome Swingarm	\$4,025.95
FBH200S	'97-'01 FLH Kit, Silver Spacer, Black Swingarm	\$3,595.95
FBH200SC	'97-'01 FLH Kit, Silver Spacer, Chrome Swingarm	\$3,895.95
FBH200B	'97-'01 FLH Kit, Black Spacer, Black Swingarm	\$3,595.95
FBH200BC	'97-'01 FLH Kit, Black Spacer, Chrome Swingarm	\$3,895.95
FBH280W	280-300 FLH Weld On Frame Kit	\$4,500.95
FBH800	17" x 6.25" Chromed Billet Wheel	\$995.95
FBPNTB	OE Paint Match Fender, Black (Graphics Extra)	\$399.95
FBPNTPRL	OE Paint Match Fender, Pearl (Graphics Extra)	\$399.95

B. Paul Yaffe Originals "Yaxle!" Super Trick Bagger Axle

- Completely changes the look of a bagger axle section!

PART	DESCRIPTION	MSRP
PYAX25DC	22mm Chrome Dominoed, For '08 FL	\$149.95
PYAX25DB	22mm Black, Contrast-Cut Dimple, For '08 FL	\$149.95
PYAX25SP	22mm Polished, Smooth, For '08 FL	\$149.95
PYAX10DC	1" Chrome Dominoed, For '00-'07 FL	\$149.95
PYAX10DB	1" Black, Contrast-Cut Dimple, For '00-'07 FL	\$149.95
PYAX10SP	1" Polished, Smooth, For '00-'07 FL	\$149.95
PYAX75DC	.75" Chrome Dominoed, For Pre-'00 FL	\$149.95
PYAX75DB	.75" Black, Contrast-Cut Dimple, For Pre-'00 FL	\$149.95
PYAX75SP	.75" Polished, Smooth, For Pre-'00 FL	\$149.95



NEW

PAULYAFFE ORIGINALS

A.



For '08-Later FLH

For '07 FLH

For '96-'06 FLH



A. Dragonfly Cycle Concepts Detachable Fairings & Windshields

- DFFRKBK1 or DFFSTBK1 bracket kits are required for installation of the fairing
- Provides more wind and weather protection than standard windshields
- Gives bikes the ability to have a stereo and extra gauges
- Fits Road King®, Heritage Softail®, Softail Deluxe® and Fat Boy® models
- Attach and detach in two minutes (after initial set up) – directly to factory windshield mounts
- The only detachable fairing with speakers mounted on the inside for an OE look
- Injection-molded composite materials for the best product possible
- No warping or fiber strand print-through when parts sit in the sun
- Perfectly match any two parts together without individual fitting
- Black gel-coat surface, ready to be painted
- Chrome trim and pin-striping options, too (factory colors only)!
- A variety of accessories: mirrors, stereo, 12-volt plug — most can be installed with any custom fairing order
- Warranted from manufacturing defects

PART	DESCRIPTION	MSRP
DFFDTF710T	Detachable Fairing w/ 10" Clear Windshield	\$1,099.00
DFFDTF710C	Detachable Fairing w/ 10" Tinted Windshield	\$1,099.00
DFFDTF706T	Detachable Fairing w/ 6" Clear Windshield	\$1,099.00
DFFDTF706C	Detachable Fairing w/ 6" Tinted Windshield	\$1,099.00
DFFDTF704B	Detachable Fairing w/ 4" Black Windshield	\$1,099.00
DFFDTF704C	Detachable Fairing w/ 4" Tinted Windshield	\$1,099.00
DFFRKBK1	Fairing Install Brackets For Road King®	\$150.00
DFFSTBK1	Fairing Install Brackets For Heritage Softail® & Fat Boy®	\$150.00
CUSTOM WINDSHIELDS:		
DFFWD10C	Custom 10" Windshield Only, Clear	\$79.00
DFFWD10T	Custom 10" Windshield Only, Tinted	\$79.00
DFFWD4B	Custom 4" Windshield Only, Black	\$79.00
DFFWD4T	Custom 4" Windshield Only, Tinted	\$79.00
DFFWD6C	Custom 6" Windshield Only, Clear	\$79.00
DFFWD6T	Custom 6" Windshield Only, Tinted	\$79.00

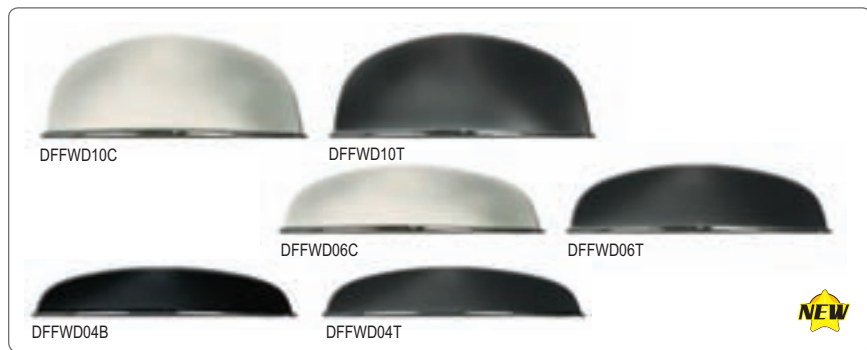

B. Dragonfly Cycle Concepts Stereo Covers

- These marine-grade covers work for models with 6" x 9" design only
- Does not fit Electra Glide® models

PART	DESCRIPTION	MSRP
DFACDSC	CD Stereo Sliding Cover For 6" x 9" Design	\$35.00
DFACHRTR	Upgrade Chrome Sliding Cover Trim Ring	\$35.00
DFARCHRTR	Replacement Chrome Sliding Cover Trim Ring	\$40.00



C. Dragonfly Cycle Concepts Stereo Upgrade

- Works with factory hand controls!
- Fits Electra Glide®, Ultra Classic, Street Glide® and Road Glide®!
- Includes a marine-grade, detachable face Kenwood® CD stereo; Kenwood® 5.25" speakers; antenna; adapter face plate; interface box and mounting hardware
- The head unit will play MP3 encoded disks and will work with portable devices such as an MP3 player or iPod®
- USB ports will work with portable devices such as MP3 flash drives and iPod®
- Sirius® Satellite Radio and HD radio ready
- Adapter face plate allows the stereo to cleanly fit into the stock stereo opening

PART	DESCRIPTION	MSRP
DFSEGUP	Stereo Upgrade Kit	\$699.00

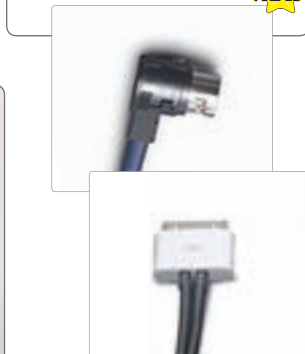

D. Dragonfly Cycle Concepts Stereo Adapter for iPod®

This interface can be wired into a side-bag for easy removal with stereo upgrade!

PART	DESCRIPTION	MSRP
DFSTPSP	Adapter For iPod®	\$120.00

Hell's Foundry Audio System Upgrades

- **ULTIMATE sound UPGRADE for touring motorcycles**
- The ONLY purpose-built amplifier w/ marine-grade speakers to feed cravings for better sound on your touring motorcycles
- Ten minute "plug and play" installation
- Features a proprietary protection circuit with no adjustment ever!
- Completely sealed, 1.5" x 3.25" x 4.25"
- The smallest, most powerful mobile amp in its class



NEW

PART	DESCRIPTION	MSRP
HFPADB525	Polk Audio, 5.25" Speaker Upgrade Pkg.	\$99.95
HFFLAS9405	150W Titan Amp & Polk Audio 5.25" Pkg. For '94-'05 Tour	\$599.95
HFFLAS0608	150W Titan Amp & Polk Audio 5.25" Pkg. For '06-'08 Tour	\$599.95

Hell's Foundry Headlight Trim For Road Glide®

- Exclusive Hell's Foundry designed chrome headlight trim for FLT Road Glide®
- Simple installation
- Does not significantly affect headlight performance
- Sold in pairs
- All steel construction



NEW

PART	DESCRIPTION	MSRP
HFFLTF	Flame Headlight Trim For Road Glide®	\$99.95
HFFLTS	Skull Headlight Trim For Road Glide®	\$99.95
HFFLTBO	Tri-Bar Open Headlight Trim For Road Glide®	\$99.95
HFFLTBR	Beauty Ring Headlight Trim For Road Glide®	\$99.95
HFFLTTW	Web Headlight Trim For Road Glide®	\$99.95
HFFLTMC	Maltese Cross Headlight Trim For Road Glide®	\$99.95

Hell's Foundry Striping Packs

NEW

• Easy-to-install vinyl graphic kit includes two or six color matched vinyl stripes, instructions, and squeegee applicator

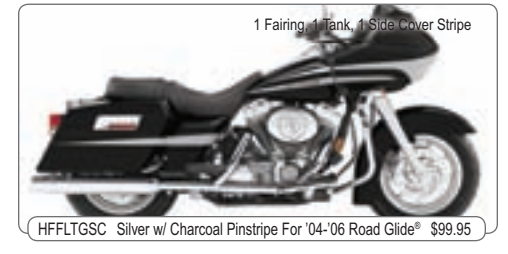
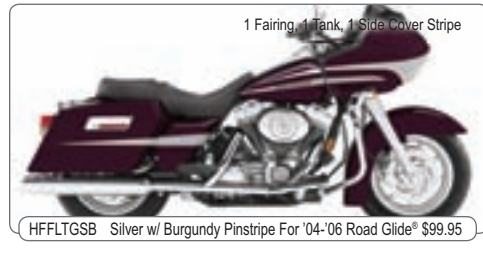
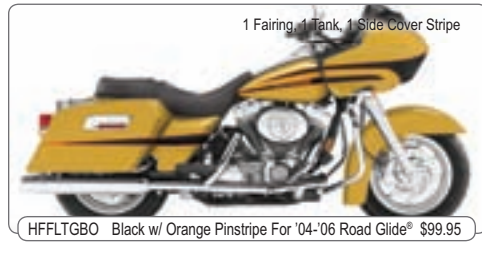
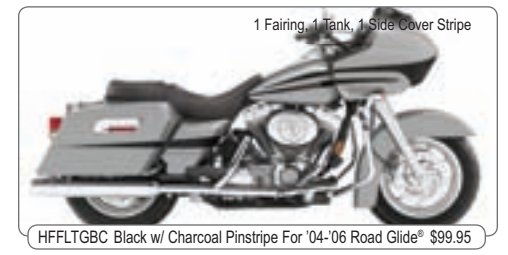
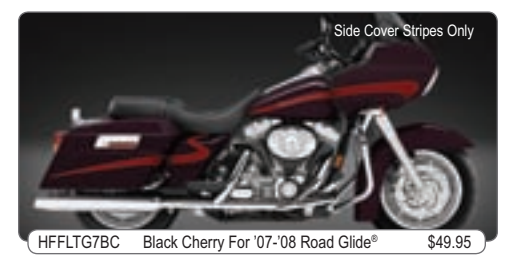
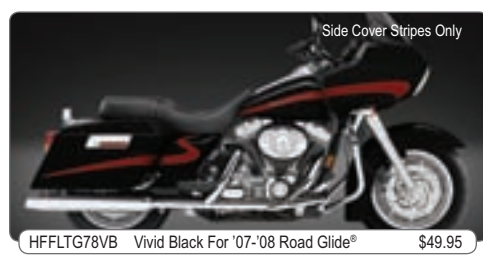
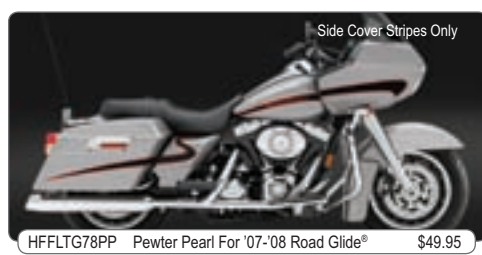



A. Dakota Digital® Six Gauge Packages For Baggers

- Complete six gauge set plugs directly into the stock wiring
- Fits '06-later fairing models including Road Glide®
- Includes speedometer with odometer and dual trip meters, tachometer, oil pressure, oil temperature, voltage, and fuel level gauges
- Additional features include clock, gear position, 0-60 time, ¼ mile time, ¼ mile per hour, 0-60 MPH, high speed and RPM recall
- Includes cruise on and cruise engaged indicators as well as security and check engine lights
- Extremely bright blue LED displays are highly viewable in sunlight!

PART	DESCRIPTION	MSRP
DDMCL3006OT	For '06-Later Bagger Models	\$1,165.00
DDMCL3000OT	For '96-'05 Bagger Models	\$1,165.00



B. Freedom-Wings Air Diversion System

- With wings open, air is directed at the rider to provide cool airflow
- When closed, air is deflected outward and around the rider
- Polycarbonate wings with anodized brackets and front side buttons
- Installs in less than 15 minutes
- USA made

PART	DESCRIPTION	MSRP
FW001	Smoke For '96-'07 FLHT, FLHTC & FLHTCU, Set	\$79.95
FW003	Smoke, '08-Later, Set	\$79.95
FW002	Black, '96-'07 FLHT, FLHTC & FLHTCU, Set	\$79.95
FW004	Black, '08-Later, Set	\$79.95



C. Hell's Foundry Pre-Wired 1.25" Bars For Road Glide®

- High polished, 1.25" stainless steel
- Drilled for internal wiring for a clean custom look
- This is the only direct replacement FLTR/I oversized bar available that uses the OE height, width and pull-back
- Allows use of stock length throttle, brake and clutch cables

PART	DESCRIPTION	MSRP
HFFLT125	1.25" Internal Wired Handlebar For Road Glide®, Chrome	\$199.95
HFFLT125B	1.25" Internal Wired Handlebar For Road Glide®, Black	\$199.95
HFFLTR125	Billet risers for use with 1.25" Chubby Bars	\$99.95



D. Klock Werks Kustom Dash For Dressers

- Visually extend a tank by painting it to match
- Dash must be used with a vented low-profile gas cap (not included)

PART	DESCRIPTION	MSRP
KWFLD	Short-Style Seats For FLH, Natural Finish	\$279.00
KWRKD	Long-Style Seats For Road King®, Natural Finish	\$289.00



E. Dragonfly Cycle Concepts Tachometer Bracket For Road King®

Mounts to current dash — chrome billet construction

PART	DESCRIPTION	MSRP
DFATABR	Tachometer Bracket For Road King® Classic/Standard Only	\$149.00

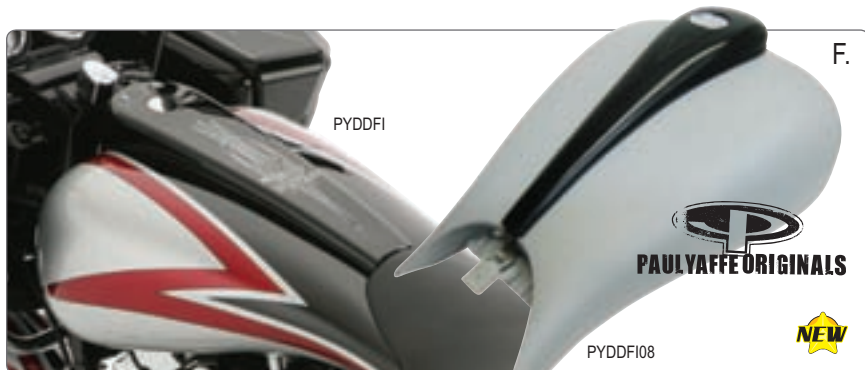

F. Paul Yaffe Originals "Bagger Nation" Dash Kits

- A selection of replacement dash kits to lose that bulky stock unit
- Carb dash and pre-'08 dash are sold extra long for stretched tanks — highest quality hand laid fiberglass
- Each kit includes dash, gas cap, trim rubber, hardware and instructions
- Add instant swoop to any bagger

PART	DESCRIPTION	MSRP
PYDDFI	Dash For Pre-'08 FI Baggers	\$199.95
PYDD	Dash For Carbureted Baggers	\$199.95
PYDDFI08	Dash For '08-Later FI Baggers	\$199.95



G. Wicked Image Touring Mirrors

- Touring mirror head and mount with 2" convex blind spot inset

PART	DESCRIPTION	MSRP
WZ2009	Chrome	\$149.95
WZ2010	Black	\$149.95

A. Paul Yaffe Originals Fenders

- Deep drawn from 12 gauge steel (bullet proof and the strongest available)
- These babies aren't spun and welded, they are made from one piece!!
- Each fender is shipped raw and not drilled so it can be slammed down low
- Additional fender spacing is required

PART	DESCRIPTION	MSRP
PYFF13	Wild Front Fender For Wide Glide®	\$299.95
PYFF12	Wild Front Fender For Deuce®	\$299.95
PYFF19	DEI Front Fender For 21" x 5"	\$299.95
PYFF21	UDUIT Front Fender For 21" x 5"	\$299.95
PYFF20	Thicky Front Fender For 21" x 5"	\$299.95
PYFF18	Hi-5 Front Fender For Wide Glide®	\$299.95
PYFF14	Hi-5 Front Fender For Deuce®	\$299.95
PYFF2	Talon Front Fender For Wide Glide®	\$299.95
PYFF1	Talon Front Fender For Deuce®	\$299.95
PYRF1	Fatty Rear Fender For 10.5"	\$299.95
PY1618FS	Front Fender Spacers For 16"/18" On Wide Glide®	\$91.95
PY2135FS	Front Fender Spacers For 21" On Wide Glide®	\$91.95

B. Sumax Overlay Rear Fenders For Bagger Models

- Lay right over the existing stock fender to fill the gap between the bags and frame
- Attach at seat tab mount and under the seat
- Tough outer composite is finished with grey primer gel coat

PART	DESCRIPTION	MSRP
SM8754	Overlay Fender For '97-Later FLT	\$207.00
SM8754FD	Overlay Fender w/ License Plate Recess	\$228.00

C. Sumax Overlay Rear Fenders For Softail®

- Lay right over the existing stock fender to fill the gap between the bags and frame
- Attach at seat tab mount and under the seat
- Tough outer composite is finished with grey primer gel coat

PART	DESCRIPTION	MSRP
SM8756	Overlay Fender For FXST	\$207.00
SM8756FD	Overlay Fender w/ License Plate Recess For FXST	\$228.00
SM8759	Overlay Sub-Fender For '97-'06 FXST	\$64.00

D. Sumax Sweeper Rear Fenders For FL Models

- Tough outer composite is finished with grey primer gel coat

PART	DESCRIPTION	MSRP
SM8719	Lobby Sweeper Rear Fender For FL	\$225.00





A.



C.



B.

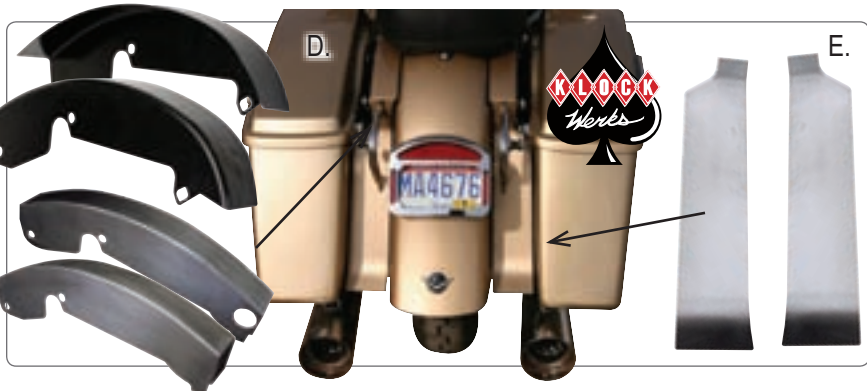

D.

E.



F.



G.

A. Sumax Hugger Front Fender For Wide Glide®

- 6.5" mount tab width designed for 16" or low profile 18" tires
- Tough outer composite is finished with grey primer gel coat

PART	DESCRIPTION	MSRP
SM8716	Hugger 6.5" Front Fender For Wide Glide® 16" Wheels	\$145.00

B. Sumax Sweeper Front Fenders For Wide Glide®

- Front Loboy Sweeper 8718 series has mounting ears...no spacers required!
- Tough outer composite is finished with grey primer gel coat

PART	DESCRIPTION	MSRP
SM8654	6.5" Front Fender For Wide Glide® 16" Wheels	\$165.00
SM8718	Front Fender w/ Ears For FL w/ Wide Glide®	\$165.00

C. FBI™ FLH Bagger Front Scoop

- Show off an FLH's aggressive nature with this primed fiberglass scoop

PART	DESCRIPTION	MSRP
FBHSCOOP	Front Scoop For '96-'05 FLH	\$139.95

D. Klock Werks Kustom Bagger Upper Fillers

- Accent a bagger's fender to hide stock clutter
- Steel with black e-coating, ready for color-match paint
- One version fits the models with or without detachable backrest — the other fits bikes with a detachable tour pack
- On FLHX models, the fillers mate up to the stock fender/lower filler combo that comes stock
- Lower filler does not fit FLTCU model bags with factory trim in place

PART	DESCRIPTION	MSRP
KWUPSG	For '06-'07 FLHX Street Glide® w/ Tour-Pak® Radiused Edges	\$165.00
KWUPT	For '97-'07 FLH/R/TR w/ Trunk Mounts	\$169.95
KWUPS	For '97-'07 FLH/R/TR (Smooth)	\$169.95

E. Klock Werks Kustom Bagger Lower Fillers

- Eliminate gaps between the bags and fender while highlighting its contours
- Color-match for a smooth transition without losing the contours of the bike
- Use with or without the top fillers — raw, ready-to-paint finish.
- Includes fitsments for:

PART	DESCRIPTION	MSRP
KWLF	'93-'04 FLH/R/TR (Smooth)	\$100.00
KWLF1	'93-'04 FLH/R/TR Works w/ Trunk Hardware	\$100.00
KWLF2	'97-'05 FLH/R/TR (Smooth) Extended Bags	\$100.00
KWLF3	'97-'05 FLH/R/TR Detachable Tour-Pak® Extended Bags	\$100.00

F. Sumax Standard Big Ass Bags For FLH Models

- 30% more cargo space thanks to 2.5" more width!
- Fits '93-Later FLHT, FLHRC, FLHR, FLHX, FLTR, FLHTC & FLHTCU models
- Inside finished with a dark heather trunk lining
- Tough outer composite is finished with grey primer gel coat
- Rubber grommets with quick release hardware
- Torque hinge holds lid in position

PART	DESCRIPTION	MSRP
SM8750	Saddlebags, Stock	\$965.00
SM8751	Saddlebags, +2" Wider	\$1,029.00
SM8751L	Saddlebags, +2" Wider, Top Lifts Off	\$1,029.00
SM8758	Phantom Saddlebag Bracket, Black	\$184.00

G. Sumax Big Ass Bags For '86-Later Softail®

- Inside is finished with a dark heather trunk lining
- Lots of cargo space with a locking chrome latch
- Directional lights located on fender rails must be relocated
- Exhausts must be located under rear axle for bag clearance
- Brackets attach at two stock locations on the fender rails and one point behind the rear passenger pegs
- 1/4 turn fasteners for quick and easy removal

PART	DESCRIPTION	MSRP
SM8752	Saddlebags, Stock, For '86-Later FXST	\$965.00
SM8752B	Saddlebags w/ Brackets, Stock, For '86-Later FXST	\$1,286.00
SM8753	Saddlebags, +2 Wider, For '86-Later FXST	\$1,029.00
SM8753B	Saddlebags w/ Brackets, +2 Wider, For '86-Later FXST	\$1,393.00
SM8761	Phantom Saddlebag Bracket, Black	\$294.00

ENGINE
FUEL SYSTEMS
EXHAUST
ELECTRICAL
DRIVETRAIN
WHEELS
SUSPENSION
SHEETMETAL
FRAMES
CONTROLS
LIGHTING
BAGGERS
TOOLS
APPAREL

A. Stampede™ Bag Extensions

Be a leader in the customized bagger craze! These great new Stampede™ fiberglass bag extensions add that low sleek look to your ride that's been super hot in recent bike shows and magazines! Why just bolt them on? Install these extensions to your factory fiberglass bags, glass them in and paint to match for a seamless, custom look.

PART	DESCRIPTION	MSRP
STBE	Bag Extensions, All H-D® Bags	\$289.95



B. Paul Yaffe Originals Taillights

- Super bright LED's that function as taillight, turn signal and strobing brake lights
- Increase visibility over 50% while making baggers look 100% cooler
- Machined from 6061 T6 billet then beautifully chrome plated
- Simple bolt-on installation
- Plug in harness included with sets of two
- CNC machined from ABS, these little guys will make quick work out of frenching Spade or Wedgie Bag Lights into your saddlebags for that custom hot rod look!

PART	DESCRIPTION	MSRP
PYSTL	Spade Taillight	\$239.95
PYFS	Spade Frenched Box	\$59.95
PYTLWL	Wedgie Taillight, Left	\$239.95
PYTLWR	Wedgie Taillight, Right	\$239.95
PYFW	Wedgie Frenched Box	\$59.95
PYLIK	Installation Kit For Bag Lights	\$59.95



C. Leather Luggage

Saddlebags: The great looking, quick-release black saddlebags feature genuine leather with studs, buckle straps and a subtle, yet durable top handle. The slanted saddlebag features stylish studs and conchos to set it apart from the rest!

Backrest Bag: The backrest bag features a universal design for use on diverse back rest sizes. The highly functional travel case and travel bag are separate for handy use then buckle together for secure travel. Features studs and conchos for added flair!

Tool Bags: Our tool bags use genuine black leather with conchos, studs and buckled straps.

PART	DESCRIPTION	MSRP
SVSSR	Saddlebag w/ Steel Reinforcement, 9.5" x 15" x 6"	\$149.99
SVSXLS	Saddlebag, Slanted Design, 21" Diag. x 8" x 11"	\$194.99
SVBFS	Saddlebag w/ Flamed Stitching, 9.5" x 15" x 6"	\$194.99
SVBS	Back Rest Bag, 22" x 12" x 12.5"	\$124.99
SVBTC	Tool Bag w/ Conchos & Studs, 11" x 4" x 4"	\$34.99
SVBTB	Tool Bag w/ Braided Trim, 12" x 4" x 5"	\$41.99





Hell's Foundry Rack For Tour-Pak®

- Finally an effective way to store Tour-Pak® and detachable accessories while not in use
- Securely holds one Tour Pak®, one back rest and two helmets at the SAME TIME
- Adjustable to fit all H-D® detachable accessories
- Made of solid steel and finished in fine textured black powdercoat for long term durability
- Completely assembled and ready for installation
- Lifetime warranty

PART	DESCRIPTION	MSRP
HFTPRB	Textured Black	\$124.95
HFTPRSV	Silver Vein	\$124.95

NEW

A. Metro Air Force® Blaster Dryers

- Take bikes from dripping to dry in a few minutes
- Includes 10' hose, heavy duty blower nozzle and five detailing nozzles
- Also available for ease of use are a carrying case and a wall/table bracket with 10' hose extension kit
- Master Blaster features two 4.0 H.P. motors, three adjustable speeds and five detailing nozzles
- The Sidekick is a compact, powerful hand held motorcycle dryer that is small enough to put into a saddle bag

AB3CD	Blaster	\$239.99
AMB3CD	Master Blaster	\$429.99
ABSK	Blaster "Sidekick"	\$99.99
ABCC	Carrying Case	\$74.99
ABHB	Bracket w/ Hose	\$59.99



B. Wham Bam Detailer

- Specially formulated cleansing and polishing agent that contains no waxes, silicones, Teflon®, petroleum distillates, abrasives or harmful additives to damage paint, chrome, lexan, fiberglass or leather
- Combines the advantages of a superior protective finish of a wax job and rejuvenation process of a polisher

PART	DESCRIPTION	MSRP
BCWB01	WhamBAM Detailer	\$29.95

C. Wham Bam All Metal Polish

- A unique liquid formula that produces a "mirror-like" shine in aluminum, magnesium, stainless, brass, nickel, etc.
- Ability to melt oxidation and simultaneously bring up the metal's true brilliance cannot be matched by any other polish

PART	DESCRIPTION	MSRP
BCWB02	WhamBAM All Metal Polish	\$17.95

D. Kal-Gard Cleaners & Lubricants

- **Filter Cleaner:** Spray this product on greasy, dirt -clogged filters, rinse with clean water, and that's it! It works fast and is extremely effective. Even the thickest grunge just melts away instantly, leaving your filter clean and ready to use. Completely water soluble and bio-degradable. Used on all foam and fabric filters.
- **Foam Filter Oil:** A special blend of oil and a high-tack bonding agent that stops sand, dirt and other contaminants from passing through the filter.
- **Degreaser:** Ideal when fast removal of grease and oil is necessary. Penetrates rapidly and rinses clean with water. Contains no harmful chemicals that will damage surfaces. Great for all kinds of vehicles and even floors. Water soluble and biodegradable.
- **30/30 All-Purpose Lubricant:** A penetrant and light lubricant that works fast, is harmless to most plastics, paints and rubber and metal. Perfect for preventing corrosion when salt water or high humidity is a problem. It will end squeaks while loosening rust and providing protection for metal parts.
- **Contact Cleaner:** Remove brake fluid, grease and dirt from internal components of electronic equipment and devices like, radios, compact disc players, electronic ignitions and computers. Extends the life of electronic components. It quickly flushes away grease oil, dirt and dust. There is no need to disassemble small delicate electronics.

PART	DESCRIPTION	MSRP
KG1116	Filter Cleaner, 16 oz. Bottle	\$6.63
KG1116C	Filter Cleaner, Case (12) 16 oz. Bottles	\$79.56
KG1118	Filter Cleaner, 1 Gal.	\$25.76
KG1118C	Filter Cleaner, Case (4) 1 Gal. Jugs	\$103.04
KG1315	Foam Filter Oil, 13 oz. Aerosol Can	\$7.33
KG1315C	Foam Filter Oil, Case (12) Aerosol Cans	\$87.96
KG1716	Degreaser, 13 oz. Aerosol Can	\$6.65
KG1716C	Degreaser, Case (12) 13 oz. Aerosol Cans	\$81.12
KG6	30/30 All-Purpose Lubricant, 13 oz. Aerosol Can	\$5.93
KG6C	30/30 All-Purpose Lubricant, (12) 13 oz. Aerosol Cans	\$71.16
KG50113	Contact Cleaner, 13 oz. Aerosol Can	\$6.25
KG50113C	Contact Cleaner, (12) 13 oz. Aerosol Cans	\$75.00

E. EZ Chock Portable Chocks

- Put in the back of a pickup truck to eliminate the possibility of the tire turning
- No need to bolt down with rubber underpanel
- Straps in place
- This helps to save shocks from needing to be cranked down so tight
- Move from a truck to a trailer or hauler!

PART	DESCRIPTION	MSRP
EZC35	Portable Chock (Size: 3.5)	\$89.99
EZC55	Portable Chock (Size: 5.5)	\$99.99



Sidekick

Blaster

Master Blaster



B. - C.

NEW



D.

NEW



E.

NEW

A. Crane Cams® Tune-A-Cam Kit

- Degree camshafts into a motor for maximum performance
- Check crankshaft, camshaft end play and shaft and gear runout
- Makes it easier to performance tune a motor
- Complete with large degree wheel, checking springs, dial indicator and stand, TDC locator and detailed instructions

PART	DESCRIPTION	MSRP
CR90010	Tune-A-Cam Kit	\$356.47

B. Crane Cams® Degree Wheel

- Degree a camshaft into a motor for maximum performance

PART	DESCRIPTION	MSRP
CR90011	Degree Wheel	\$50.43

C. Crane Cams® Cam Installation Tools

- Hold all of the tappets while removing and reinstall the camshaft
- Prevents the tappets from falling out of the tappet blocks

PART	DESCRIPTION	MSRP
CR90020	Cam Installation Tools	\$43.05

D. Crane Cams® Tappet Block Alignment Tool

- Aligns the block so the tappet roller runs straight on the cam lobe
- If the tappet block is removed, align the block with the camshaft when reinstalling to prevent camshaft wear

PART	DESCRIPTION	MSRP
CR90021	Tappet Block Alignment Tool	\$16.46

E. Crane Cams® Cam Engine Assembly Lube

Specially formulated for extra lubrication during assembly and break-in

PART	DESCRIPTION	MSRP
CR990081	Cam Engine Assembly Lube	\$6.33

F. Crane Cams® TDC Stops For Twin Cam

- Find top dead center for degreasing the camshaft and marking flywheels

PART	DESCRIPTION	MSRP
CR994101	Twin Cam TDC Stop	\$13.50
CR994121	14mm TDC Stop	\$13.50

G. Motion Pro Belt Tensioning Gauge

- Compact design
- Scale for easy reference
- Designed to work with all belt drive models with a 10 lb. specification

PART	DESCRIPTION	MSRP
MP080350	Belt Tensioning Gauge	\$28.50

H. Motion Pro Rear Wheel Alignment Tool For H-D®

- Designed to help set rear wheel alignment
- Fast, accurate and easy to use
- Eliminates the need to use a tape measure
- Proper wheel alignment extends chain/sprocket and belt life

PART	DESCRIPTION	MSRP
MP080368	Wheel Alignment Tool For Softail®, Sportster®, and Dyna®	\$21.50

I. Yankee Engineuty E-Z Installation Cam Tool For Evolution®

PART	DESCRIPTION	MSRP
YECT01	E-Z Installation Cam Tool For Evolution®	\$184.04

J. Gary's Greaser Tool For Wheel Bearings

Grease wheel bearings without removing the bearing and destroying the grease seal. Remove wheel and spacers, insert tool then pack bearing with grease gun. In no time, the job is done!

PART	DESCRIPTION	MSRP
GGT	Gary's Wheel Bearing Greaser Tool	\$36.95





Tappet Block Alignment Tool
JM3344384

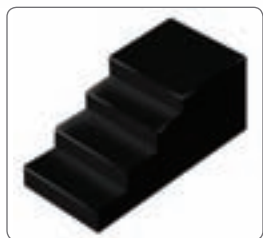

All Primary Drive Locking Tool
JM2234

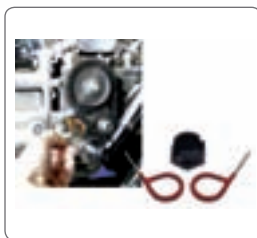

Twin Cam Chain Tension
JM1283

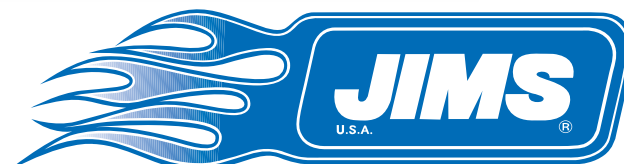

JIMS® Tools

Made in the USA by the finest motorcycle craftsmen in the world. This complete line of parts will be used in your shop for generations.

JM3344384	Tappet Block Alignment Tool	\$15.05
JM2234	All Primary Drive Locking Tool	\$41.00
JM1283	Twin Cam Chain Tension	\$38.55
JM9466037A	Locknut Wrench, Sprocket	\$139.80
JM1285	Cam / Crankshaft Sprocket	\$40.85
JM3490284	Mainshaft Bearing Race	\$186.15
JM3341680	Race & Bearing Installer	\$63.85
JM3307173	Wheel Bearing Race Remover / Installer	\$81.35
JM1277	Camshaft, Remover / Installer Twin Cam	\$137.30
JM1042	Wheel Bearing Puller Late	\$244.45
JM1279	Inner Cam Bearing Remover Twin Cam	\$131.30
JM2232	Neck Bearing Race Tool	\$69.00
JM2043	Fork Nut Socket	\$49.25
JM9455555A	Gear Shaft Nut Socket Wrench	\$38.00
JM1725	Installer, Fork Race	\$55.20
JM1278	Inner Cam Bearing Twin Cam	\$121.20
JM1006T	Engine Stand For Evolution®	\$78.60
JM2260	Final Drive Locking Tool	\$121.95
JM3851590	Clutch Spring Compressing	\$90.25
JM2388	Spacer Driver Tool	\$33.05
JM1706	Breather Reamer	\$607.75
JM1177	Case Boring Tools For 5-Speed Twin Cam	\$1,085.25
JM1409	Case Boring Tools For Evolution®	\$1,029.60
JM1408	Case Boring Tools For Late Model Twin Cam	\$1,503.60
JM9660036B	Valve Spring Compressor	\$149.75

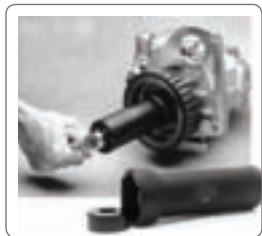

Locknut Wrench, Sprocket
JM9466037A



Cam / Crankshaft Sprocket
JM1285



Mainshaft Bearing Race
JM3490284



Race & Bearing Installer
JM3341680



Wheel Bearing Race Remover /
Installer JM3307173



Camshaft Remover / Installer
For Twin Cam JM1277



Wheel Bearing Puller Late
JM1042



Inner Cam Bearing Remover For
Twin Cam JM1279



Neck Bearing Race Tool
JM2232



Fork Nut Socket
JM2043



Gear Shaft Nut Socket Wrench
JM9455555A



Installer, Fork Race
JM1725



Inner Cam Bearing Twin Cam
JM1278



Engine Stand For Evolution®
JM1006T

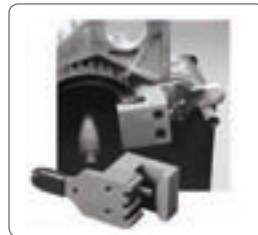

Final Drive Locking Tool
JM2260



Spacer Driver Tool
JM2388



Breather Reamer
JM1706



Case Boring Tools For 5-Speed
Twin Cam JM1177



Case Boring Tools For Evolution®
JM1409



Case Boring Tools (Late Model
Twin Cam) JM1408



Valve Spring Compressor
JM9660036B

ENGINE
FUEL SYSTEMS
EXHAUST
ELECTRICAL
DRIVETRAIN
WHEELS
SUSPENSION
SHEETMETAL
FRAMES
CONTROLS
LIGHTING
BAGGERS
TOOLS
APPAREL

A. EQUAL Tire Performance Wheel Balancing Material

- Eliminate ugly lead wheel weights
- Empty a bag of Equal into the applicator tool — with the flip of a lever, Equal is injected into the tire through the valve stem with compressed air
- Equal works for the life of the tire — constantly adjusting to changes in speed, load, temperature and tread wear
- Gives shops a less expensive way to balance tires
- Less money in equipment — no more balancers, different size weights or time involved in removing tires from the bike
- Saves time involved in spin balancing

PART	DESCRIPTION	MSRP
EQCSM30	2 oz. Equal Packages, 30-Pack	\$299.99
EQCSM	2 oz. Equal Packages	\$9.99
EQAPPV	Wheel Balancing Material Applicator	Call



B. Air-Lock Tire Mounting Lube

- Air-Lock is a combination tire mounting lube and bead seal
- One product application allows the bead to seat freely while cellulose emulsions seal the bead to the wheel
- Built-in rust inhibitors help protect against wheel and rim corrosion
- Water based, nonflammable and ready-to-use — it leaves no build-up on the tire/wheel and helps prevent tire slippage on the wheel
- Perfect for use with EQUAL Wheel Balancing Material

PART	DESCRIPTION	MSRP
ALCS4128	Tire-Mounting Lube & Bead Seal, 1 Gal. 4-Pack	Call
AL640	Tire-Mounting Lube & Bead Seal, 5 Gal.	Call



C. Stop & Go Pocket Tire Plugger

- The most convenient way to repair a tire while it's still on the wheel.

SGTRKC	Stop & Go Tire Repair Kit w/ 4 CO ₂ Canisters	\$48.50
SGTRK	Stop & Go Tire Repair Kit	\$32.50
SGTRKSP	Fix 'n Flate Repair Kit w/ Spark Plug Hose	\$27.95



D. Signal Sorcerer™ G-4²

- Previously this traffic light changer unit was only available to security vehicles, fleets, and custom 4x4 shops
- The G-4² has a success rate of 99% up to a whopping 14" from the ground!
- Tough ABS housing — D.O.T. /EPA compliant
- Lifetime power supply — no wiring or tools

PART	DESCRIPTION	MSRP
MS005G42	Signal Sorcerer G-4 ²	\$19.95
MS005	Original Signal Sorcerer	\$19.95

E. Cruz Tools® Outback'r™ H13 Compact Tool Set

- A potent multi-tool for Harley-Davidson®
- Includes hex and Torx® keys, sockets, socket driver, screwdrivers, 10mm box wrench for battery, and 9/16" open-end wrench
- Only 10 ounces and 3.5" long

CZH13	Outback'r™ H13 Compact Tool Set	\$19.95
-------	---------------------------------	---------



F. Cruz Tools® MiniSet™ Compact Tool Kit

- Powerful and compact ratchet and socket set
- Features a midget 1/4 drive ratchet, 2" extension, 8 sockets, hex and Torx® bits
- Lifetime guaranteed — includes tough carrying case

CZMSHD1	MiniSet™ Compact Tool Kit For H-D®	\$39.95
---------	------------------------------------	---------

G. Cruz Tools® RoadTech™ H3 Tool Kit For Harley-Davidson®

- Includes mini ratchet and sockets, combinations wrenches, locking pliers, adjustable wrench, 6-in-1 screwdriver, LED flashlight, hex and Torx® keys and much more!
- All tools are mechanic-grade with a lifetime guarantee

CZRTH3	RoadTech™ H3 Tool Kit For H-D®	\$89.95
--------	--------------------------------	---------



H. Cruz Tools® EconKIT™ Tool Kits

- Comprehensive roadside solution for all H-D® (except V-Rod®).
- Includes combination and adjustable wrenches, locking pliers, hex and Torx® keys, LED flashlight, spark plug sockets, 6-in-1 screwdriver and more!
- Tools are mechanic grade and lifetime guaranteed

CZEKH1	EconKIT™ H1 Tool Kit	\$64.95
CZEKH2	EconKIT™ H2 Tool Kit	\$39.95



A. Men's Police Style Riding Jacket

- Our traditional police style black jacket has a waist belt, zipper pockets, snapped lapels and collar
- Made of cowhide with vented panels and zip-out liner, sizes M36-56

PART	DESCRIPTION	MSRP	PART	DESCRIPTION	MSRP
SVJMP36	Size 36	\$114.99	SVJMP48	Size 48	\$114.99
SVJMP38	Size 38	\$114.99	SVJMP50	Size 50	\$114.99
SVJMP40	Size 40	\$114.99	SVJMP52	Size 52	\$114.99
SVJMP42	Size 42	\$114.99	SVJMP54	Size 54	\$114.99
SVJMP44	Size 44	\$114.99	SVJMP56	Size 56	\$114.99
SVJMP46	Size 46	\$114.99			

B. Men's Contemporary Riding Jacket

- Our trendy and great-looking black riding jacket boasts clean cowhide construction
- Standing snap collar and zippered sleeves and pockets, sizes S-XXL

PART	DESCRIPTION	MSRP	PART	DESCRIPTION	MSRP
SVJMS	S	\$184.99	SVJMXL	XL	\$184.99
SVJMM	M	\$184.99	SVJM2XL	XXL	\$184.99
SVJML	L	\$184.99			

C. Men's Hoodie Leather Jacket

- Keep warmer with attached hood!
- Grade A cowhide with a polyester liner, cloth waistband and wrists

PART	DESCRIPTION	MSRP	PART	DESCRIPTION	MSRP
SVJMHM	M	\$149.99	SVJMHXXL	XXL	\$159.99
SVJMHL	L	\$149.99	SVJMHXXXL	XXXL	\$159.99
SVJMHXL	XL	\$149.99	SVJMHXXXXL	XXXXL	\$159.99

D. Women's Electra Leather Jacket

- Naked cowhide with silver stripes across chest and back
- Silver Spandex® sides, sizes XS-3XL

PART	DESCRIPTION	MSRP	PART	DESCRIPTION	MSRP
SVJWEXS	XS	\$154.99	SVJWEXL	XL	\$154.99
SVJWES	S	\$154.99	SVJWEXXL	XXL	\$169.99
SVJWEM	M	\$154.99	SVJWEXXXL	XXXL	\$169.99
SVJWEL	L	\$154.99			

E. Women's Standard Leather Jacket

- Our best selling women's black riding jacket
- Class cowhide leather exterior with narrow braided trim, sizes XS-XXL

PART	DESCRIPTION	MSRP	PART	DESCRIPTION	MSRP
SVJWBXS	XS	\$194.99	SVJWBL	L	\$194.99
SVJWB S	S	\$194.99	SVJWBXL	XL	\$194.99
SVJWBM	M	\$194.99	SVJWBXXL	XXL	\$162.99

F. Women's Corina Leather Jacket

- Black w/ Spandex® side panels for flexibility and comfort
- Zippered pockets, sizes XS-XL

PART	DESCRIPTION	MSRP	PART	DESCRIPTION	MSRP
SVJWCXS	XS	\$194.99	SVJWCXL	XL	\$194.99
SVJWC S	Small	\$194.99	SVJWCXXL	XXL	\$162.99
SVJWCM	M	\$194.99	SVJWCXXXL	XXXL	\$162.99
SVJWCL	L	\$194.99			

G. Men's Orange/Black Nylon Rainsuit

- 100% waterproof nylon
- Sizes S-3XL
- Jacket features zip front with cover flap, adjustable straps at the waist, Scotchlite® piping, elastic gather on back and elastic cuffs on wrists
- Pants feature adjustable suspenders, cargo pocket on leg and elastic ankle cuffs

PART	DESCRIPTION	MSRP	PART	DESCRIPTION	MSRP
SVRSS	Small	\$79.99	SVRSXL	XL	\$79.99
SVRSM	M	\$79.99	SVRSXXL	XXL	\$79.99
SVRSL	L	\$79.99	SVRSXXXL	XXXL	\$79.99



ENGINE
FUEL SYSTEMS
EXHAUST
ELECTRICAL
DRIVETRAIN
WHEELS
SUSPENSION
SHEETMETAL
FRAMES
CONTROLS
LIGHTING
BAGGERS
TOOLS
APPAREL

A. Spyke® "Lead Dog" T-Shirt

Show Spyke® some love with a T devoted to man's best friend, 100% preshrunk cotton.

PART	DESCRIPTION	MSRP
SPTLS	Small	\$20.00
SPTLM	Medium	\$20.00
SPTLL	Large	\$20.00
SPTLXL	XL	\$20.00
SPTLXXL	XXL	\$20.00
SPTLXXXL	XXXL	\$20.00



B. Bulletprüf® "Take Your Best Shot" T-Shirt

Take your best shot at this 100% preshrunk cotton t-shirt.

PART	DESCRIPTION	MSRP
BPTS	Small	\$20.00
BPTM	Medium	\$20.00
BPTL	Large	\$20.00
BPTXL	XL	\$20.00
BPTXXL	XXL	\$20.00
BPTXXXL	XXXL	\$20.00

Ladies, we love you too! Intimidate with this Spandex®/cotton shirt.

PART	DESCRIPTION	MSRP
BPTLS	Small	\$20.00
BPTLM	Medium	\$20.00



C. Deerskin Leather Gloves

A plush deerskin glove. Full grain deerskin with elastic wrist and rolled cuff hem. Our fingerless design has full grain deerskin with a Velcro® wrist, vented knuckles and padded palm.

PART	DESCRIPTION	MSRP
SVGDFL	Deerskin Glove, Fingerless, Men's Large	\$15.99
SVGDL	Lined Deerskin Glove, Men's Large	\$25.99

D. Leather Chaps

Our traditional riding-style black chaps are available in cow or buffalo hide, as available. Chaps have flaps on side zippers, extra long cut, and jean style front pockets. Black in sizes XS - XXXXL.

Our milled grain and lined black chaps feature cowhide with expandable Spandex® in thighs and waist for comfort. Sizes XS - XXXXL.

PART	DESCRIPTION	MSRP
SVCB	Buffalo Chaps, Men's	\$99.99
SVCMG	Black Milled Grain Leather Chaps, Men's	\$99.99

E. Leather Vests

While our cows appreciate a breeze on a hot day, you'll appreciate the cool comfort of our vest line. The Traditional black vest is buffalo hide with four front snaps in sizes XL - XXXXL. Men's side-laced deluxe black vests are cowhide with four front snaps and two pockets in sizes XS - XXXXL.

Buffalo hide is the ticket when it comes to our women's vests. The black riding vest has narrow braided trim on front and back with snap closures in sizes XS - XXL. The classic black vest has attractive trim lines, Spandex® sides, zippered pockets and front closure is sizes XS - XXL.

PART	DESCRIPTION	MSRP
SVVP	Traditional Riding Vest, Men's	\$59.99
SVVSLD	Side-Laced Riding Vest, Men's	\$59.99
SVVWBB	Riding Vest w/ Braided Trim, Women's	\$54.99
SVVWBS	Classic Riding Vest, Women's	\$54.99



F. Phantom Pad® Pillion Pads

Phantom Pads® are made with the best materials layered over sturdy urethane for years of use. Vinyl versions are constructed of premium Phantomhyde™. Phantom Gel items are available with both a bolt-down bracket and without.

PART	DESCRIPTION	MSRP
PH301L	Leather, S	\$134.95
PH303L	Leather, XL	\$134.95
PH301GEL	Phantom Gel, Small	\$154.95
PHB301GEL	Phantom Gel w/ Bracket, Small	\$164.95
PHPB301	Phantom Bag	\$154.95
PH304IC	Iron Cross	\$144.95



A.



A. GPX Helmets

GPX Helmets provide the DOT approved protection you're looking for. GPX throws in good looks, great comfort and excellent value just for good measure! Available through MC Advantages in open-faced, full-faced and shorty models, they have tough and lightweight aerodynamic gloss black polycarbonate shell, quick release clip retention system and stylish design! Their features include:

- Meets or exceeds U.S. & Canadian DOT FMVSS-218 specifications, DOT decal displayed on back
- Anti-scratch visor on shorty and open-faced models
- Ultra-soft comfort fit liner
- Available in sizes S-XL
- Compares head-to-head with leading national brands!

PART	DESCRIPTION	MSRP
GPXFFL	Full-Face Helmet, Large	\$89.99
GPXFFXL	Full-Face Helmet, X Large	\$89.99
GPXOFL	Open-Face Helmet, Large	\$49.99
GPXOFLX	Open-Face Helmet, X Large	\$49.99
GPXSS	Shorty Helmet, Small	\$49.99
GPXSM	Shorty Helmet, Medium	\$49.99
GPXSL	Shorty Helmet, Large	\$49.99
GPXSXL	Shorty Helmet, X Large	\$49.99

B. Bike Shop Electronic Catalog Software By Bridgeworks

BikeShop Full Throttle™ is a powerful multi-feature, multi-vendor web-based motorcycle parts and apparel catalog containing parts from leading distributors and manufacturers.

- Eliminate stacks of bulky printed catalogs from desk or counter
- Easily collect daily purchases and create end-of-day ordering reports
- Integrate with a shop's web site to easily create an e-commerce sales site
- Integrate with Quickbooks Point of Sale or other systems for easy tracking and invoicing

B.

SO200 Bike Shop Call



Twistin' Wrists & Turnin' Heads

DEALERS

TERMS & CONDITIONS

ACCESS DEALERS.MCADVANTAGES.COM TO CHECK STOCK, REVIEW STATUS AND ORDER PRODUCTS ONLINE!



MC Advantages sells through approved dealers only and actively supports the traditional dealer distribution network.

Visit MCAdvantges.com or call for an MC Advantages dealer application today or for dealers in your area.

Harley-Davidson, Harley, HD, H-D, Twin Cam 88, Twin Cam 88B, Twin Cam 96, Evolution, Road King, Road Glide, Dyna, Sportster, Softail, V-Rod, Wide Glide, Springer, and Tour-Pak are among the trademarks of H-D Michigan, Inc.

The following are registered marks of their respective companies and are use for reference purposes only:

- American IronHorse®
- Arlen Ness®
- Avon Tyres®
- Baker®
- Big Dog®
- Build Or BustSM
- Delrin®
- Joker Machine®
- Kawasaki®
- Kevlar®
- Metzeler®
- Outerwears®
- Performance Machine®
- RevTech®
- Roadstar®
- Saxon®
- Shadow®
- Spandex®
- Teflon®
- Torx®
- TP Engineering®
- Twaron®
- Ultima®
- Uni-Filter®
- Velcro®
- Victory®
- V-Max®
- V-Twin Expo®
- Yamaha®

PREMIER DEALER REQUIREMENTS—Dealers that achieve minimum buying levels are extended the MC Advantages Premier Dealer pricing level. To qualify, dealers need to purchase \$5000 in parts each calendar year. Dealers that do not reach the \$5000 level at year end will revert back to standard wholesale pricing. If a dealer starts a new year at wholesale level or a new dealer comes on during the year, they will be elevated to Premier once they achieve \$5000 in purchases. The order that puts a dealer over \$5000 will be at Premier pricing.

PAYMENT AT TIME OF ORDER—Typical payment for all orders is advanced payment at time of order by credit card, wire transfer or by C.O.D./money order. Payment by company check is available upon approval of credit and successful completion of required guidelines. All orders for special order/non-stocking products and orders exceeding \$2500.00 must be paid for in advance of shipment as indicated above. Certain exceptions to this policy may be permitted and will be approved only by MC Advantages management.

FREIGHT—All orders are shipped either prepaid by credit card (VISA, Mastercard, Discover or American Express) or in certain circumstances, COD, cashiers check, company check or money order. We ship via ground unless otherwise specified. Next day and 2nd day delivery are available for most products at a higher cost and these expedited charges are not included in MC Advantages offer of free freight over a stated order amount—the difference in normal ground shipment and the chosen expedited freight will be added to the invoice for the order in accordance with our "Blue To You" Program. International orders require bank wire transfer in US dollars only and all freight and freight related charges will be added to the invoice for that order as the "Free Freight" offer does not apply to International orders. MC Advantages is not responsible for late deliveries by any particular carrier. **Note: The following items may require a shipping surcharge: frame assemblies, rolling chassis, engines, bike kits, exhausts, fenders, front ends, batteries, handlebars and other items based on size or weight. Ask a sales rep for details.**

FREIGHT CLAIMS—All orders are carefully inspected and packaged before shipment. Damage occurring in transit must be reported to the carrier, immediately upon receipt and notated on the delivery ticket. It is the responsibility of the recipient to promptly inspect and report damage or shipment shortages to the shipping company and to MC Advantages. Responsibility for damages or shortages after leaving our warehouse lies with the carrier and not MC Advantages. If freight damage does occur it must be noted on the bill of lading at time of receipt and claim for damages filed with the carrier. We generally use UPS, but may on occasion use other shippers. The carriers' ability to deliver in a certain period of time is beyond our control. MC Advantages is not responsible for delays caused by shippers.

PRICES—Prices and descriptions contained in our catalog and on our website are subject to change without notice. Call to confirm exact current pricing prior to ordering.

BACK ORDERS—Back orders will be kept open and shipped as soon as possible.

GENERAL PRODUCT WARRANTY—Many of MC Advantages' products carry one year or more in manufacturer's warranty. These warranties generally warrant that product is free from defects in material and workmanship for the stated period of time from date of purchase. This warranty applies to the original customer/installation with proof of purchase and cover defects in materials and workmanship provided that the product was correctly ordered and properly installed/fitted for its intended use. If upon inspection, returned parts are determined to be defective, they may be replaced or repaired at the option of MC Advantages and/or the original manufacturer. MC Advantages reserves the right to determine if a product warrants a repair or partial replacement of any parts.

WARRANTY AND LIABILITY LIMITATIONS—Except as may be expressly set forth in a product invoice, MC Advantages makes no representations or warranties as to any of its products, expressed or implied, including w/o limitation any warranties or merchantability or fitness for a particular purpose. Motorcycles can be dangerous. MC Advantages has no control over the usage of any part and MC Advantages expects all users of its products to exercise good judgment as to the proper selection, installation, use and maintenance of any parts. All merchandise is guaranteed against defects in material and workmanship only. **Replacement will be limited to parts only and does not include incurred labor costs.**

MC Advantages assumes no responsibility for damage or injury of any kind due to the misuse or improper application of any parts in any way by any person. MC Advantages shall not be liable for any indirect or consequential damages whatsoever. All matters shall be interpreted under Iowa law. All MC Advantages products are for custom made motorcycles. The fitment of our products to OEM or custom motorcycles and/or OEM or custom motorcycle parts is the responsibility of the end user. MC Advantages makes no warranty or specific claim of fitment. The user is responsible for verifying suitability of MC Advantages products to their application prior to ordering. It is highly recommended that the end user carefully test fit all parts prior to any modifications or painting. MC Advantages cannot be held responsible for any paint or labor costs, under any circumstances, and will not accept for return any part that has been modified or damaged during installation.

RETURNS, EXCHANGES, AND CANCELLATIONS—All items should be inspected upon receipt, preferably while the shipping representative is still present. Many MC Advantages products such as Frames, Motors, Front Ends and other products are specially ordered or custom made to end user specifications. As such, they cannot be changed, cancelled, or returned for any reason other than warranty repair once the order has been placed. Non-custom products may be returned within 30 days, and may be subject to a 20% re-stocking fee. Should returns be required, original purchaser must first contact MC Advantages, to establish if product will be returned to MC Advantages or to the manufacture, and to obtain a Returned Goods Authorization (RGA) number and RGA form. All Returns must be accompanied by an RGA form. This form shall be filled out in its entirety and the RGA number written on the outside of the box for easy identification. The RGA form must contain a detailed reason for the return. Do not sign an RGA form or return product until speaking to an MC Advantages representative and discussing possible costs and completion times. All return freight charges will be paid by the customer. All products must be returned via a traceable delivery method. Returned goods must be shipped prepaid, insured, and in the original packaging. No CODs will be accepted. MC Advantages will not be responsible for items sent to us w/o an RGA number on the box and completed RGA form.

NON-WARRANTY REPAIRS—Non-warranty repairs may be arranged with the original manufacturer of a product. However, all service work returns must be pre-paid by cashiers check if work is to be completed by MC Advantages. Please always call MC Advantages first, then follow return instructions above for returning products.

For any questions about an order or a specific MC Advantages product, call 1-800-726-9620 8:30 AM to 5:30 PM weekdays, CST.

INDEX

A

Acculight Ignition, Spyke	43
Adjure®	83, 104
Air-Lock Tire Mounting Lube	124
Air Cleaner Adapters & Brackets	28, 31, 32, 33, 34
Air Cleaners	29, 30, 31, 32, 33, 34
Air Cleaner Covers	32
Air Compressor for Shocks	77, 78
Air Filters, Replacement	19, 32
Air Filter Recharger, Filter Oil	19
Air Shocks	76, 77, 78, 113
American Suspension	74, 80, 81
Antenna, Hidden	109
A.R.S.E. Security	110
Audio System Upgrade	116
Auto Clutch	58
Auto Gem®	105
Auto Meter®	See Pro Cycle®
Avalon Front End	79
Axles	83, 114

B

Backrest Bag	120
Badlands	107
Bagger Accessories	112-121
Bags, Leather	126
Banjo Fitting	80
Banshee Belt Drive Cover	66
Batteries	52
Battery Cables	51
Battery Chargers, Testers, Accessories	53
Battery Tender®	53
Bearing Support	65
Belt Drives	62,63, 64, 65
Belt Drive Covers	65, 66, 67
Belt Drive "Fix"	56, 63
Belt Guards	66, 67
Belt Tensioning Gauge	122
Belts, Primary & Final Drive	61
Big Bore & Stroker Kits	10
BikeShop Electronic Catalog	126
Blaster Dryers	121
Blue•Job	42
Boardtrack Racer Frame	90
Bolt Kits	See Fasteners
Booster Kits	27
Bowl Bolt Kits	27
Brake Lights	See License Plate Frames
Brake Lines	20, 21
Brake Pads	73, 80
Brake Calipers, Rotors, Rebuild Kit	74, 75, 80
Brake Tee	20
Breather Bolts	15
Breather Bracket	28, 31
Breather Gear	16

Breather Valves	15
Breather Vents	15, 16
Bridgeworks	127
Brute III, IV, V, Force, Slimline (Primo)	62, 63,64,65
Buell®, Engine for	6
Bullet Lights	105
Bulletproof Electronics	107, 110
Bulleprüf®	33, 42, 52, 54, 55, 56, 58, 59, 61, 62,63, 77, 81, 88, 94, 96, 98, 99, 101, 102, 103, 106, 126

C

Cables, Cable Clamps	95
Calipers	See Brake Calipers
Cam Covers	8
Cam Installation Tool	122
Cam Plates	11, 12
Cam Shafts	11, 12
Carburetors	26, 27
Carburetor Rebuild Kit	27
Carburetor Support Bracket, Adapters	28, 32
Cateye Customs	98
Chain	61
Chain Drive Kit	62
Charging System	54
Chaps, Leather	126
Chesapeake Performance, Inc.	47, 66, 67, 97, 108
Chocks, Wheel	121
Choke Knob	27
Clamps, Cable	95
Cleaner, Detailer	121
Clutch	58, 61, 62
Clutch, Hydraulic Conversion Kit	61, 96
Clutch, Internal Cable Kit	94
Clutch Plates, replacement	59
Coil Covers, Mounts, Brackets	47, 48, 49, 50
Coils	46, 47
Cometic Gaskets®	22
Compression Releases, Button Covers	55
Compu-Fire	43, 50, 53, 54, 55, 56
Contact Cleaner	121
Crane Cams®	11, 12, 13, 44, 45, 46, 122
Crankcases	8
Crankcase Breather	31
Crime Scene Choppers	15, 17, 34, 42, 67, 86, 88, 89, 104, 105, 106
Criminal Customs	20
Cruz Tools®	124
Custom Cycle Control Systems®	93
Cyclesmiths	97
Cyclone Security	110
Cylinder Heads & Kits	See Heads

D

D&M Custom Cycle	15, 29, 30, 31
Dakota Digital®	109, 117

Dashes	117
Daytona Twin Tec	24, 25, 44, 45, 47
Decal Package	2
Dealer Software	127
Degreaser	121
Derby Cover	62, 65
Detroit Bros.®	29, 39, 59, 67, 99, 104, 105
Diaphragm Spring	59
Diagnostic System	47
Distributors	46
Doherty Machine	16, 71
Dragonfly Concepts	115, 117
Drive Side Brake System	74
Dryers	121
Duro Tires	72
Dynatek®, Dyna®	25, 44, 45, 46

E

Edelbrock®	14
EFI	14
Electronic Catalog	127
Electrical Cleaner	121
Engines	4, 5, 6, 7, 112
Engine, Touring	5, 112
Engine Cases	8
Engine & Drivetrain Packages	7
Engine Sentry™	17
Enrichment Knobs	27
Equal Wheel Balancing Material	124
Exhaust	34, 35, 36, 37, 38, 39, 40, 41, 42, 112, 113
Exhaust Cleaner/Polish	42
Exhaust Flanges & Gaskets	42
Exhaust Tips	40, 42
Exhaust Step Adapters	42
EZ Chock	121

F

Fairings	115
Fat Baggers, Inc.™	114
Fat Daddy Spoked Wheels	71
Fender Spacers, Brackets & Braces	84, 118
Fender Struts	84
Fenders	84, 85, 114, 118, 119
Feuling™	11, 12, 13, 16, 17
Fillers, for Saddlebags	119
Filters - Air	19
Filters - Oil	18, 121
Filters - Cleaner	121
Floorboard Shift Kit	99, 113
Flywheels	11
Footpegs	98
Force Motor Products	32, 33, 42
Forcewinder Intake	32, 33
Forge-Tec	68
Fork Brace	82
Fork Stop	80

Forward Controls	58, 99, 100, 101
Frames	90
Frame, Rigid Conversion Kit	90
Freedom Wings	117
Front End Accessories	80, 81, 82
Front Ends	79, 80, 81, 82
Fuel Filters	20
Fuel Fragrance	19
Fuel Injection Modules	24, 25
Fuel Lines	20
Fuel Pump	21
Fuel Systems	9
Fuel Systems, VFI	5

G

Gary's Greaser	71, 122
Gas Caps	88
Gas Tanks, Tank Liner	87
Gaskets	22, 23,62
Gates	61
Gauge Cups, Mounts & Clamps	108, 110
Gauges	103, 108, 109, 110, 117
Gear Covers	8
Gear Indicators	109
Gear Sets	55, 60
Gen 3 Starters, Compu-Fire	56
Gloves, Leather	126
Golan Fuel Products	20, 21
Goldammer Cycle Works	29
GP Designs	65, 94
GPX Helmets	127
Grandeur Cycle®	50, 53, 58, 67, 88, 94, 99, 101
Grips	98, 100
GS Motor Company	82
Gussets, Frame	92

H

Handlebars	93, 94, 96, 117
Hand Controls & Switches	94, 96
Hawg Halters	74, 75
Head Bolt Covers	15
Headlights, Trim	104, 107, 116
Heads	14
Hell's Foundry	59, 113, 116, 117, 121
Helmets	126
Hi-Lo Air Shocks	76, 78, 113
Hooker Headers®	35, 40, 41, 42, 112
Hose Ends	21
Hose Tool	80
Hot Setup® Kits	9
Hydraulic Clutch Actuator, Cover	65, 93
Hydraulic Clutch Conversion Kit	61
Ignition Switches	47, 48, 107
Ignitions	43, 44, 45

Induction Kits, System	5, 24, 33
Inspection Cover	62, 65
iPod Adapter	115
IST Ignition, S&S	44

J

Jackets, Leather	125
Jackshaft, Belt Drive "Fix"	56, 63
JBN	104
Jet Scream	24
JIMS®	8, 10, 11, 12, 14, 15, 16, 60, 61, 123
Jockey Shifts	58, 99

K

K&N®	19
Kal-Gard	121
Kickstands	99
Kiwi Motorcycle Company	82
Klock Werks	117, 119
Kraft/Tech	83, 84, 85, 86, 87, 91
Krank Vents	15

L

L.A. County Choprods®	88, 106
Leaf Spring Forks	82
Leather Jackets	125
Lever	96, 97
License Plate Frames, Brackets	106
Liner for Gas Tank	87
Lifter Kits	12
Light Controllers/Modules	107, 110
Lighting	104, 105, 107
Liquid Horsepower	19
Load Equalizers	107
Locks, Security	110
Lowering Kits	78, 81
Lubricants	121, 122
Luggage	120

M

Main Shaft Support	65
Manhattan Oil	19
Martin Bros.®	35, 36, 37, 38, 82, 90, 113
Maximum	103, 106
Mean Street Products	79
Mercury Customs	48
Metal Motorsport, Inc.	69
Metal Polish	121
Metro Air Force	121
Mirrors & Mirror Stems	102, 103, 117
Motion Pro	95, 122
Motor Mounts	17, 48, 49
Mufflers	34, 35, 42, 112

N

Neon Hot Wires	51
Novello	50

O

Octane Booster	19
Oil, For V-Twins	18
Oil Blow-By Prevention	15, 16
Oil Collector (Oil Foil)	16

Oil Coolers	17, 18, 66
Oil Filter Brackets & Mounts	17
Oil Filters	17, 18, 121
Oil Lines	21
Oil Line Install Kit	8
Oil Pumps	16
Oil Scavenger	18
Oil Tanks	86, 87
Oil Treatment	19
Oil Trough	18

P

Padlock Brakes	74
Pan Engine, Pan Conversion Kit	6, 7, 8, 14
Paul Yaffe Originals	84, 114, 117, 118, 120
PB Choppers	49, 89
Performance Plus	71, 73
Petcock	21
Phantom Pad	126
Pillion Pad	89, 126
Pinion Gear, Conversion Kit	55, 63
Plug Wires	50, 51
Polish	42, 121
Poly Pan Gel	89
Power Booster	27
Power Package, EFI	14
Power Tubes	27
Pressure Plate	61
Primary Rebuild Kit	63
Primary Drives	62, 63, 64, 65
Primary Covers, Inner & Outer	62, 65, 66, 67
Primary Cover Adapter	66
Primary Seal Kit	65
Primary Spacers	See Spacers - Primary
Primo	62, 63, 64, 65, 66, 67
Pro-Clutch	58
Pro Cycle®	110
Progressive Suspension®	76, 77, 78, 113
ProWire Wiring System	48
Prowler®	60, 65, 92
PSI Big Air Carburetor	26
Pulleys, Wheel	70, 71
Pulley, Drive	114
Pully Nut (Mega Nut)	61
Pump, Air for Shocks	77
Pure Power!	18
Pushrods	12, 13

R

Rack for Tour-Pak®	121
Rain Suit	125
Reed Valve	15
Renegade Belt Drive	64
Renegade Dual Belt Drive	65
Ride Wright	71
Rigid Frame Conversion Kit	90
Ring Gear	55
Risers	94
Rivera Engineering	58, 62
Road Max	82
Rocker Arms	14

Rocker Covers	15
Rocker Shaft	14
Roller Packages	91, 92
Rotors, wheel	70, 71
Russell	20, 21, 71

S

S&S®4, 5, 6, 7, 8, 9, 10, 11, 12, 13, 15, 16, 18, 21, 23, 25, 27, 29, 33, 34, 35, 43, 44, 46, 47, 55, 58, 60, 61, 65, 112	
Saddlebags	119, 120, 126
Saddlebag Extensions	120
Scoop, Front for FLH	119
Seats	89, 126
Seat Mounting Kit	88, 89
Seat Pan Kit	88, 89
Security	110
Shifters, Toe	99, 113
Shift Knob	58, 99
Shift Linkages	59, 113
Shocks	76, 77, 78, 113
Shovel, Engine for	6, 7, 14, 15
Shotgun Shocks	76
Sidewinder Kit, S&S	10
Signal Sorcerer	124
Signs, MC Adv. P.O.P.	2
Single-Sided Swingarm	91
Sinkhole Customs	93
Sissy Bars	89
Slave Cylinder, Clutch	61
Slip-On Mufflers	112
Software	127
Solenoid Repair Kit	55
Spacers - Exhaust	39
Spacers - Primary & Shaft Extension	63
Spacers - Fender	See Fender Spacers
Spacers - Wheel	71
Spark Plug Wires	50, 51
Speedometer	108, 109, 110, 117
Sportster, Engine for	6
Springs, Front End	81
Springer Style Front End	81, 82
Sprotors (Sprocket Brake)	74
Spyke®	15, 21, 43, 46, 51, 52, 54, 55, 56, 57, 81, 126
Stainless Creations	28, 38, 39
Stampede™	15, 16, 17, 27, 43, 50, 55, 61, 70, 75, 82, 83, 88, 89, 90, 91, 92, 94, 96, 98, 99, 100, 101, 108, 113, 120
Starter Buttons	55
Starter Drives/Clutches	55
Starter Jackshafts	56, 63
Starters	56
Stealth Starters	57
Stereo Covers	115
Stereo Upgrade	115, 116
Stop 'n Go	124
Striping Packs	116
Stroker Kits	See Big Bore & Stroker Kits
Sumax	118, 119
Swingarms	83, 91, 92
Switches	47, 48, 94, 96

T

Tachometer	108, 109, 110, 117
Taillights	105, 106, 120
Tank Selector	21
Tappets	12, 13
Tauer Machine®	64, 65, 66
Taylor Plug Wires	51
TDC Stops	122
TFI/Techlusion	25
Throttle Kits, Internal	94
Throttle Housing	98
Thunderstart™	52
Tires	72
Tire Mounting Lube	124
Tire Repair Kit	1224
Tools	11, 71, 80, 122, 123, 124
Tool Bags, Leather	120
Transmissions, Cases, Rebuild Kit	60
Transmission Plate, Universal	61
Trap Door Kit, Transmission	60
Triple Trees	81
T-Shirts	126
Turn Signals	103, 106, 107

U

U.S. Choppers	61, 90
---------------	--------

V

Velocity Stacks	28, 29
Vests, leather	126
VFI	25, 31
Voltage Regulators, Mounting Brackets	17, 53, 54

W

Warlord Belt Drive	64
Warrior Belt Drive	64
Wham Bam	121
Wheels	68, 69, 70, 71, 114
Wheel Alignment Tool	122
Wheel Balancing System	124
Wheel Bearing Greaser Tool	71, 122
Wheel Chocks	121
Wheel Spacers	71
Wicked Image	59, 99, 103, 113, 117
Wide Tire Kits	83, 114
Wild 1®	93
Windshields	115
Wire Plus	47, 107, 110
Wiring Harnesses, Extensions	50, 107

X

Xena™	110
-------	-----

Y

Yankee Engineuity	16, 18, 48, 49, 50, 96, 108, 122
Yost Performance	27

Our Very Own **Freakshow**

As one of the sponsoring partners for the 2007 AMD World Championship of Custom Bike Building, MC Advantages was invited to award their choice for best bike in the show. The MC Advantages team selected Freakshow Choppers' Fantasma del Lago as their Partner Pick. This distinction, awarded by MC Advantages General Manager Kent Reed, recognized the bike that best represented the MC Advantages product line and customer base.

"Jay Burnham and the Freakshow Choppers team had a great bike with an absolutely wicked look and paint job," said Reed. "It features a number of parts that customers can purchase from their MC Advantages dealer like an American Suspension Front End, Spyke® Stealth Starter, 360 Brake, Custom

"Phantasma Del Lago"

Cycle Control System Bars and Chesapeake Performance Belt Drive Cover," he said.

The World Championship of Custom Bike Building is hosted annually by American Motorcycle Dealer Magazine at the Sturgis Rally and Races in Sturgis, S.D. MC Advantages is an official partner of the premier custom motorcycle event which hosted 175 entries from 10 different countries.

Photos courtesy of American Motorcycle Dealer Magazine and Christa Rivington.

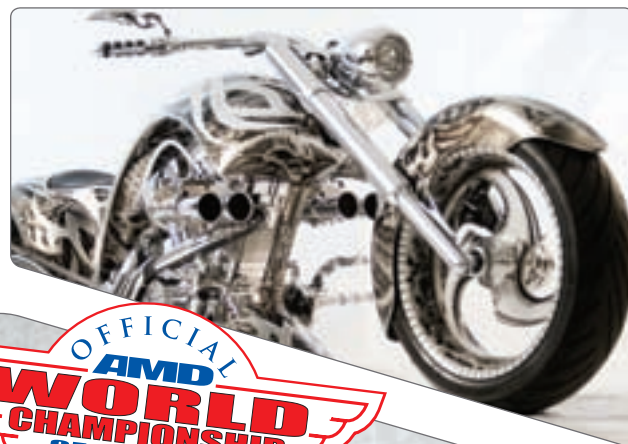

110+
Vendors
Including:



MC

DEALERS:



Place orders, check stock, review past orders and
pick your favorites for ease ordering at:
<http://Dealers.MCAdvantages.com>

**RETAIL
CUSTOMERS:**



Place orders, check stock and review past orders
on our Dealer-Driven Web Shop at:
<http://www.MCAdvantages.com>

MC Advantages
10440 NW 54th Ave
Grimes, IA 50111
TF: 1.800.726.9620
FX: 1.515.369.4321
TECH: 1.515.369.4357
MCAdvantages.com
Dealers.MCAdvantages.com